



ON Semiconductor®



Farnell®

AN AVNET COMPANY



TRANSFORM YOUR THINKING

Comprehensive solutions for advanced
electrification and ADAS subsystems
from ON Semiconductor



Automotive Solutions

Table of Contents

AUTOMOTIVE EXPERTISE	2	LIGHTING	22
Automotive Solutions	4	IN-VEHICLE NETWORKING (IVN)	31
Automotive Excellence	5	BODY	35
Automotive Technology	6	POWERTRAIN	45
Automotive Quality	7	POWER MANAGEMENT	53
Functional Safety Management	8	AUDIO	71
HEV/EV	9	PROTECTION	78
SENSORS	15	COMPONENTS	80

**For More Information, Visit the Automotive Applications Page
at www.onsemi.com/automotive**



Viewing, ADAS, and Autonomous Driving

- Viewing – Forward & Surround
- ADAS & Autonomous Driving
 - ♦ Adaptive Cruise Control
 - ♦ Blind Spot Monitoring
 - ♦ Auto-Braking
 - ♦ Lane Departure Warning
 - ♦ Pedestrian, Vehicle, and Sign Detection
 - ♦ eMirror
- Gesture Control
- Driver/Passenger Monitoring
- Ultra-Sonic Park Assist
- Power Supplies
- Electronic Parking Brake
- Smart Passive Sensing
- Electronic Power Steering

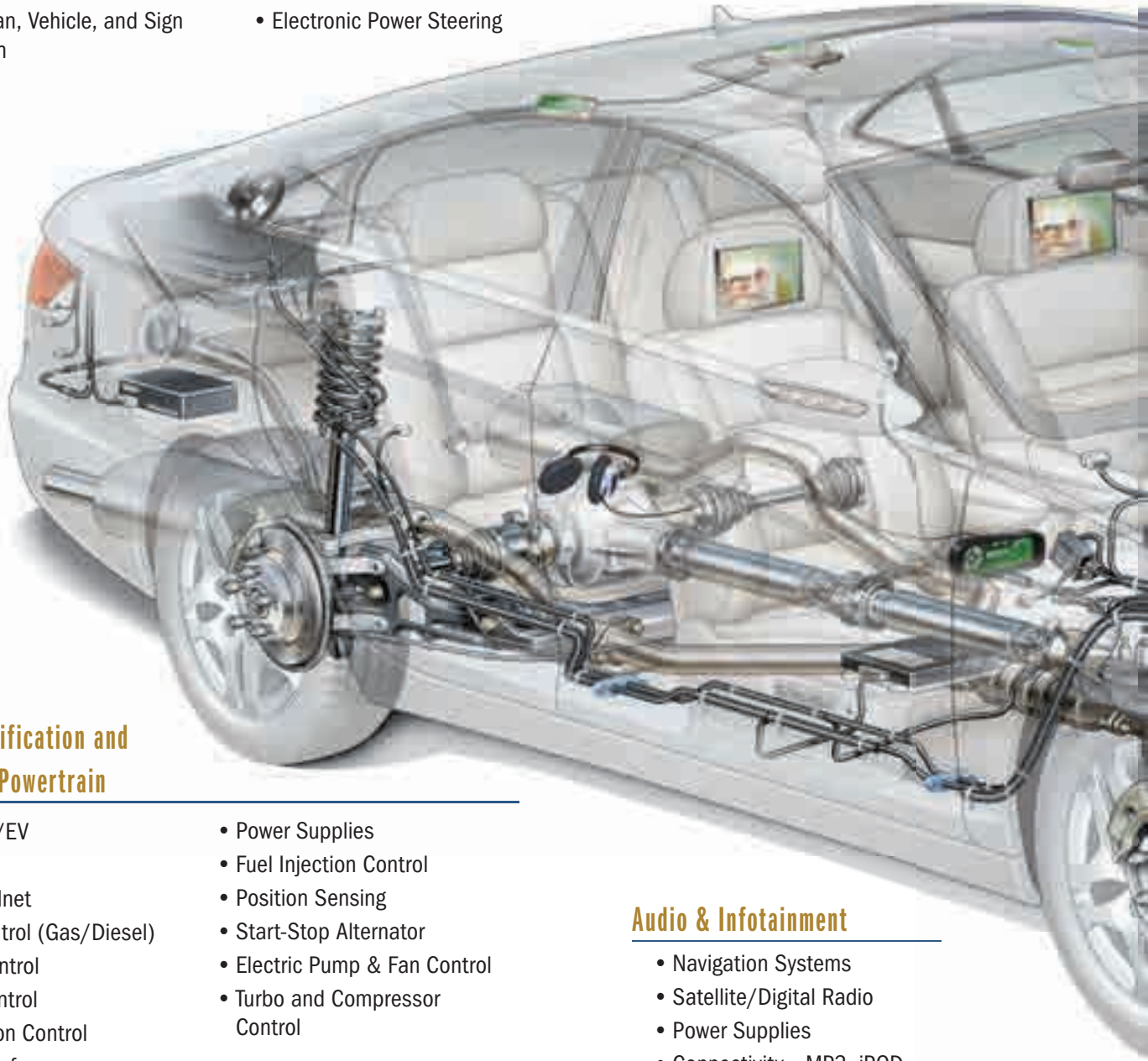

Vehicle Electrification and Conventional Powertrain

- HEV/PHEV/EV
- Fuel Cell
- 48 V Boardnet
- Engine Control (Gas/Diesel)
- Throttle Control
- Ignition Control
- Transmission Control
- Sensor Interface
- Power Supplies
- Fuel Injection Control
- Position Sensing
- Start-Stop Alternator
- Electric Pump & Fan Control
- Turbo and Compressor Control

Audio & Infotainment

- Navigation Systems
- Satellite/Digital Radio
- Power Supplies
- Connectivity – MP3, iPod, HDMI, USB, Wireless

ON Semiconductor enables energy efficient automotive solutions that reduce emissions, improve fuel economy, and enhance lighting, safety, connectivity, and infotainment power delivery systems. The company provides a broad array of image sensors, power discretes, power management, protection, processing, signal conditioning and control products that deliver solutions focused on areas such as; powertrain, viewing, ADAS, led lighting, climate control, door zone, park assist, IVN, body control and infotainment applications.

Body & Convenience

- Climate Control
- Instrument Clusters
- Smart Junction Boxes
- Power Supplies
- Electric-Chromic Mirrors
- Seat Positioning, Heating & Cooling
- Door/Mirror/Window Control
- Steering Wheel Sensors
- Smart Passive Sensing
- Body Computers & Gateways

LED Lighting

- Interior: Door, Dome, RGB Accent, Puddle
- Exterior: CHMSLs, RCLs, Accent
- Advanced Front Lighting & Motor Control
 - ◆ Pixel Lighting
 - ◆ OLED Lighting

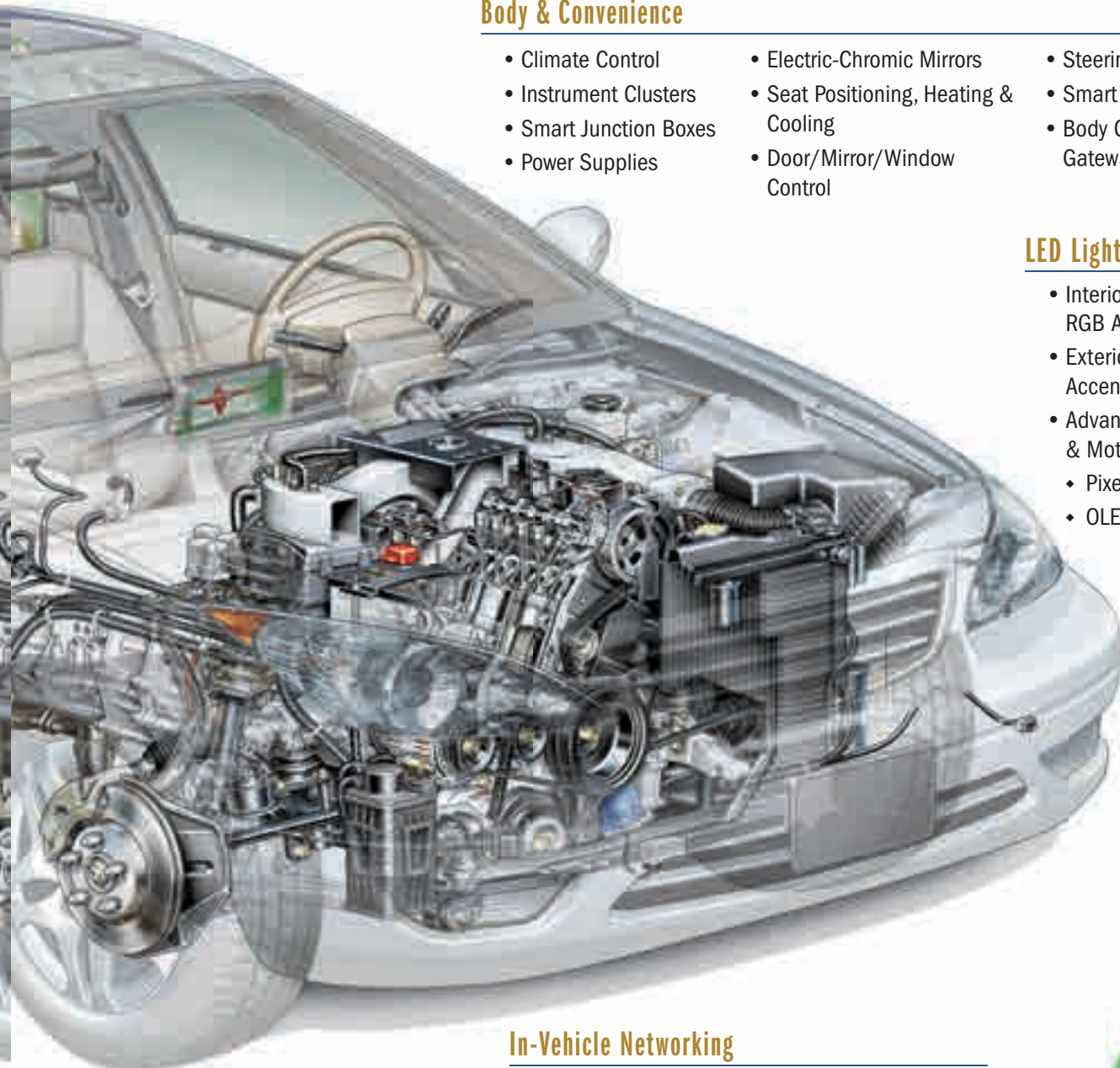

In-Vehicle Networking

- LIN
- CAN
- System Basis Chips
- FlexRay™
- PSi5
- SENT
- Ethernet
- USB



Automotive Solutions

Automotive powertrain and body electronics solutions from ON Semiconductor provide an optimized architecture, matched to customer requirements. The company provides multiple options, based on technology and application:

- Application Specific Integrated Circuits (ASIC)
- Application Specific Standard Products (ASSP)
- Image sensors and co-processors
- In-vehicle networking
- Standard integrated circuits
- Discrete components
- Analog
- Mixed-signal
- SBCs and SoCs
- Sensor interfaces

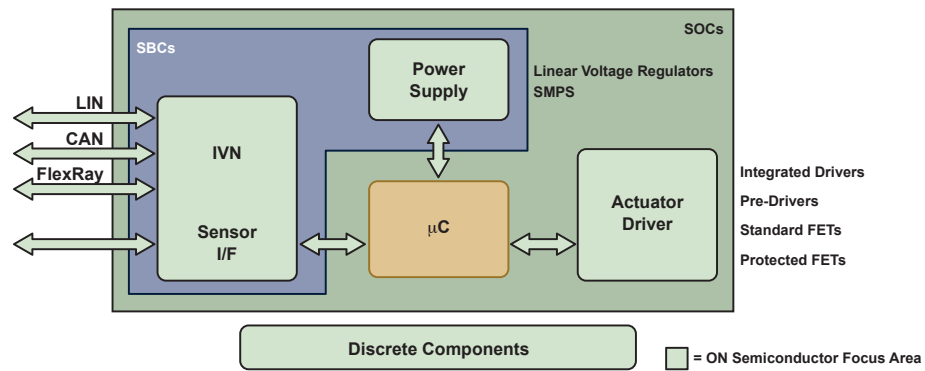

Automotive Excellence

Automotive Expertise

ON Semiconductor provides energy efficient silicon solutions to the global automotive industry. The company has developed a wide range of automotive components, by applying advanced technology and extensive R&D expertise, in the fields of high-voltage interfacing, smart power management, in-vehicle networking, system level integration, and sensor interfaces.

In-house expertise includes:

- ASIC, ASSP, standard IC, and discrete capability
- Mixed-signal technologies
- High-voltage processes
- Directly owned and operated fabrication facilities
- Class A clean rooms
- High temperature wafer testing
- Burn-in capability
- Wafers and die

Solutions Engineering Centers

ON Semiconductor operates Solution Engineering Centers in Munich, Germany; Shanghai, China; and Tokyo, Japan. These SECs, located in automotive industry centers, provide local customer support, including application knowledge and system integration skills. Together with local technical field teams and product specialists, the automotive SECs provide the following services:

- Local technical support (system and device)
- Reference designs and demonstration boards
- Global application architecture consultation
- Optimization of system costs and performances
- Design integration support (ON Semiconductor devices into customer applications)
- Component specification and customer/application test specifications

Global Supply Chain Operations

Advanced Capability

ON Semiconductor invests in EDI, VMI, and other logistics agreements.

Global Locations

Worldwide, ON Semiconductor employs ~34,000 people. Headquartered in Phoenix, Arizona, U.S.A., the company owns and operates multiple development centers and manufacturing facilities located in the U.S.A., Europe, and Asia.

Global Supply Chain

ON Semiconductor operates a flexible, reliable, responsive supply chain that supports complex manufacturing networks and dynamic global market conditions. This includes multiple manufacturing and logistics sites located near our customers to ensure supply continuity.

Automotive Long-Term Availability Statement

ON Semiconductor is 100% committed to the long-term supply of products in concert with the automotive industry's supply benchmark requirement. The company works with customers to meet their specific supply requirements. ON Semiconductor will make all commercially reasonable efforts to provide automotive customers with advance notice of phase-outs and provide compatible product renewals, when technically feasible and within certain cost constraints, to help ensure long-term supply considerations and requirements are fully achieved.

Automotive Technology

Proven Automotive Technical Capabilities

ON Semiconductor has developed a set of dedicated, high-voltage automotive power technologies. With parasitic signals running through automobiles, 80 V spikes can occur and must be accounted for by the design team. Modules and components need to be able to sustain such peaks and remain functional. ON Semiconductor technology enables complex, high-voltage system-on-chip (SoC) solutions that meet requirements for maximum voltage and digital gate integration.

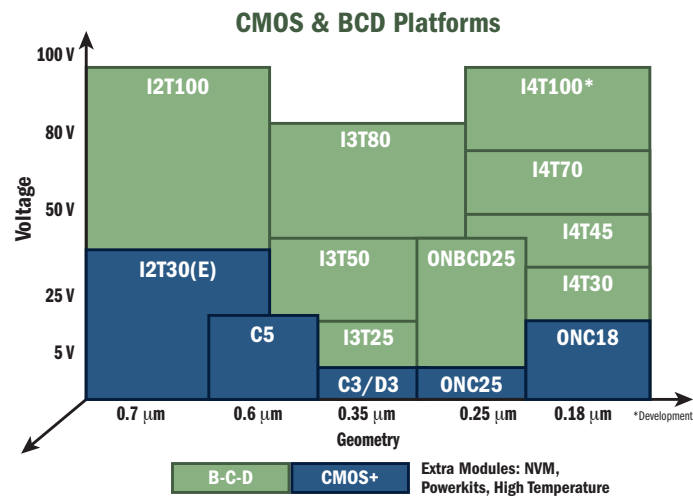

Electro Magnetic Compatibility

In-Vehicle-Networking (IVN) applications require extended immunity against ESD pulses and EMI. Growing vehicle electronic content makes this even more important, and automobile

manufacturers set performance standards accordingly. ON Semiconductor offers best-in-class devices using I3T50/80 and I4T30/45/70 technologies, that provide advanced capabilities. Robust designs are achieved, for example, by deep trench isolation, which reduces the interference between the voltage domains on the chip.

ON Semiconductor offers a range of technologies that allow up to 100 V supply, and enables component integration – including embedded microprocessor cores.

ON Semiconductor technologies serve as the basis for automotive ASIC and application specific standard product (ASSP) solutions for powertrain (including high temperature applications with ambient temperatures $\geq 150^{\circ}\text{C}$), safety, body, dashboard, in-vehicle-networking (IVN), sensors, and actuator applications.

High Temperature Capability

ON Semiconductor offers a broad portfolio of products that operate in extended temperature ranges, up to 150°C . The company has also launched an initiative to extend high temperature capabilities to 200°C . This initiative includes enhancements to:

- Packaging and Bonding
- High Temperature Testing
- Component Test Vehicles
- Product Test Vehicles
- CAD Tools
- Libraries
- Spice Device Models

Extended high temperature capabilities may be applied to ASICs and ASSPs.

Automotive Quality

Automotive Grade Quality and Control Processes

For over 40 years, ON Semiconductor has been developing and delivering robust, high-performance solutions that allow designers to meet the demanding environmental and performance requirements of automotive applications.

Quality Policy: *“We will exceed Customer Expectations with our Superior Products and Services.”*

Quality Statement: *“Every ON employee is personally responsible for ensuring the highest Quality in the products and services delivered to internal and external customers. Continuous improvement in the Quality of our processes, products and service is fundamental to the achievement of customer satisfaction.”*

For certification documents, visit the Quality page on our Web site.

ON Semiconductor Quality Processes

- Registered to ISO 9001
- Registered to IATF 16949
- Quality System and Business Operating System are synonymous and are documented to meet the requirements of the Automotive Standards
- Corrective action systems use various methodologies to ensure we identify and correct the root cause of non-conformance. Preventive action is also used to ensure we eliminate potential non-conformances
- Quality System/Business Processes are documented and controlled

Production Part Approval Process (PPAP)

Our documented process provides the methods, procedures, and forms to initiate PPAP submission; prepare the documents required for submission; and document customer approval when required. This process ensures that ON Semiconductor components comply with design specifications, and that customer designs will maintain desired quality levels.

Zero-Defect Program

Focused Parts “Non-Zero” devices (bottoms-up approach)

- Problem solving methodology
- Adequate Failure Analysis facilities
- Incident ownership

Prevent Recurrence Systemic Improvement (top-down approach)

- Process characterization, control plan, and Failure Mode Effect Analysis
- Maverick lot initiative
- Quarterly detailed Horizon Reports

ON Semiconductor’s commitment to the automotive market extends beyond the delivery of great products, to ensuring that our manufacturing and quality processes meet the industry’s need for reliability and robustness. The demanding standards of the automotive industry drive the company’s design, manufacturing, and delivery processes. ON Semiconductor delivered over 73 billion parts in 2017, with average defect rates of less than 160 parts-per-billion.

Change Management Processes

ON Semiconductor proactively manages product changes to ensure Safe Customer Passage and Flawless Execution.

- ON Semiconductor follows the JEDEC 46D and JEDEC48C for all markets except automotive. For the automotive market we follow ZVEI – Guideline for Customer Notifications of Product and/or Process Changes (PCN) of Electronic Components for Automotive Market for our change management process.
- Automotive Reliability Testing performed per Automotive Electronic Council (AEC) Q100/Q101
- Use of detailed Process/Parameter Matching Checklist
- Use of detailed changes process flow, with various checkpoints during and after the change implementation
- Use of program management methodology
- Customers notified through Product Change Notifications

Functional Safety Management: Development According to ISO 26262

Functional Safety at ON Semiconductor

ON Semiconductor has a long and successful history of mixed signal integrated circuit developments targeting safety critical applications. Following the release of the ISO 26262 standard in November 2011, ON Semiconductor created a dedicated Functional Safety team and implemented a dedicated design flow to support the development of devices targeting safety critical applications according to this new standard. This initiative has proven to be successful, as today the company has experience with the development of mixed-signal integrated circuits targeting applications with safety goals up to ASIL D.

ON Semiconductor is highly involved in the Functional Safety community, especially in ISO 26262. The company is a member of the ISO 26262 work group (TC22/SC3/WG16), as well as part of the new ISO 26262 related semiconductor sub-work group that is clarifying the standard for semiconductor developments.

Creation of Dedicated and Independent Team

The purpose of the project independent team is to create a safety culture in the company and to guarantee an independent and critical look on the way functional safety will be guaranteed during the development of the devices. This independent team, driven partly by the quality department and partly by product development, has responsibility to guide the project Functional Safety Managers as well as the development teams assigned to the different developments, and provide the tools needed to follow the flow as described by the ISO 26262 standard.

Enhancing Experience

Through the ongoing developments and the dedicated Functional Safety Structure, ON Semiconductor is attaining even more significant experience, and is ready to support customers for automotive Functional Safety related projects.

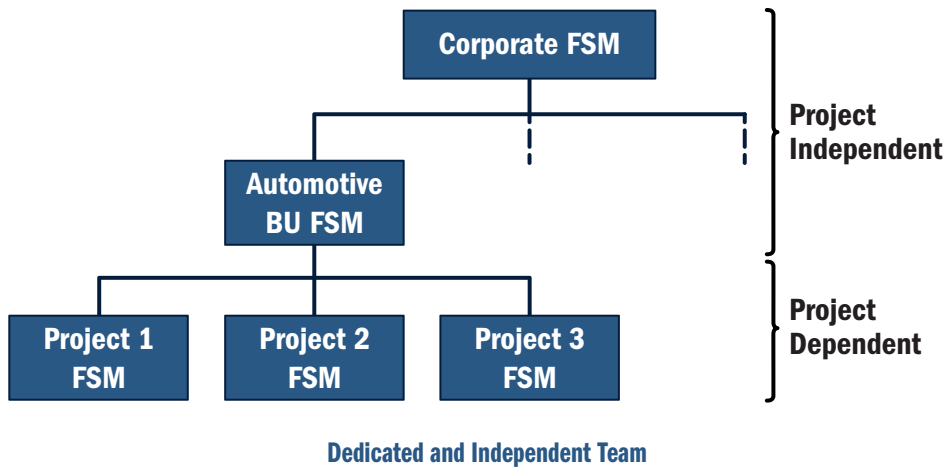

48 V Starter/Generator

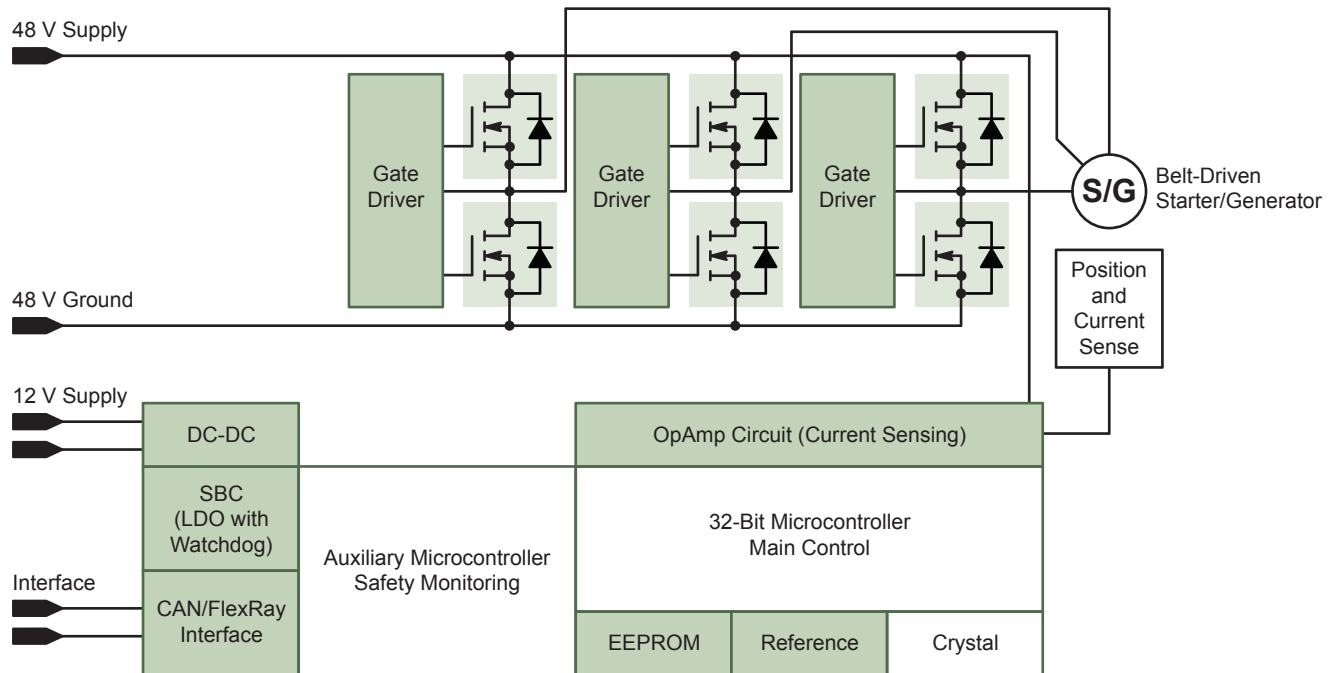

Key Products & Features

Current Sense Amplifiers: *NCV2007x, NCV21x*

- High-side and low-side current sensing
- Low offset zero-drift architecture
- Flexible system supply voltage
- Low value current sense resistors for better power efficiency
- Temperature sensitive applications
- AEC-Q100 Qualified

MV MOSFETs: *FDBL863xx-F085, FDBL860xx-F085 & NVMFS6H8xx*

- Flat-lead performance packages (SO-8 FL & TOLL)
- Very low $R_{DS(ON)}$
- Small footprint, high current
- Superior reliability/robustness
- AEC-Q101 Qualified

High/Low Side MOSFET Drivers: *NCV51511, FAN7191-F085, NCV5183*

- High current capabilities
- Down to 30 ns Propagation delay
- Pin-to-pin compatible with industry standards
- AEC-Q100 Qualified

On-Board Charger

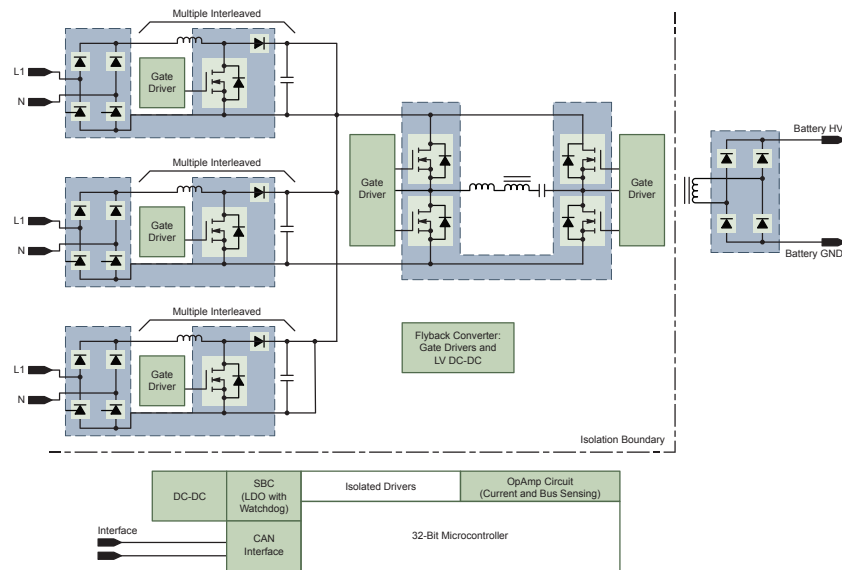

Key Products & Features

HV MOSFETs (SuperFET®): FCHxxN60F-F085, FCHxxxN65F-F085

- Low on-resistance and low gate charge performance
- Low conduction loss
- Fast Switching speeds
- Withstand extreme dv/dt rate and higher avalanche energy
- AEC-Q101 Qualified

Discrete IGBTs: AFGB30/40T65SQDN, FGB/H40T65SPD-F085, FGH40/60N60SMD-F085, FGH40/60N60SFDTU_F085

- Fast switching
- Low cost
- AEC-Q101 Qualified

High Voltage Gate Drivers: NCV570x, NCV51xx and FAN71xx-F085

- Family of rail-to-rail high current drivers for lower system losses
- External (opto/silicon) or built-in galvanic isolation in multiple packages for design flexibility
- Short propagation delays for faster switching
- Suitable for single ended, half bridge, and full bridge topologies
- AEC-Q100 Qualified

MOSFET Modules: FAM65CRxxDZ1*, FAM65CRxxADNZ1*, FAM65HRxxDS1*

- High thermal performance
- Enhanced EMI, isolation, and current capabilities
- System level cost reduction
- Enable compact system solution with proven reliability

HV Rectifiers: RURxxxx-F085, RHRGxxxx-F085, ISL9Rxx60x2-F085, FFH50US60S-F085

- Both low VCE(sat) and high speed version available for rectification and fast switching
- Avalanche energy rated
- AEC-Q101 Qualified

SiC Rectifiers: FFSHxxxxB-F085*, FFSPxxxxB-F085*, FFSDxxxB-F085*

- Superior switching performance in comparison to silicon
- Excellent thermal performance
- Fast operating frequency
- Increase power density and reduced EMI

670 V Flyback Converters: NCV106x, NCV107x

- Enables compact designs for isolated and non-isolated systems
- Output power from 2 W to 15 W
- AEC-Q100 Qualified

* Pending 4Q18.

EV Charging Stations

ON Semiconductor has a wide portfolio of products and solutions to cover the different topologies, approaches, and architectures that come with this emerging market. SiC Diodes & MOSFETs complement traditional Super-Junction and IGBT solutions, and modules can bring further benefits in terms of system integration and performance.

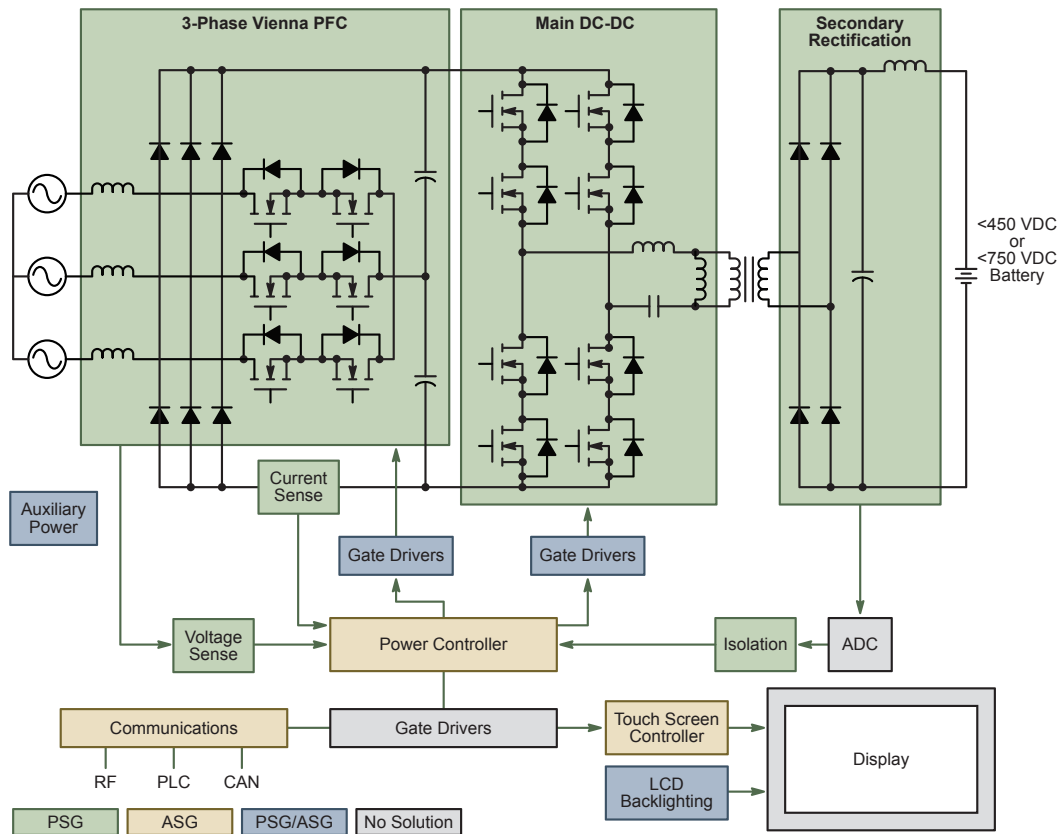

650 V SuperFET® III MOSFETs

- FCH023N65S3 – 23 mΩ, TO-247
- FCH040N65S3 – 40 mΩ, TO-247
- FCP067N65S3 – 67 mΩ, TO-220

High Voltage Rectifiers

- FFP30S60S – 600 V, 30 A, STEALTH II
- FFPF10UP60S – 600 V, 10 A, Ultrafast II
- RHRG75120 – 1200 V, 75 A, Hyperfast

High Voltage Gate Drivers

- FOD8342 – 3 A Optocoupler Gate Driver
- NCD5700 – High Current Gate Driver
- NCP51705 – 6 A SiC MOSFET Driver

Silicon Carbide Diodes

- FFSH40120ADN – 1200 V, 40 A, TO-247
- FFSH20120A – 1200 V, 20 A, TO-247
- FFS2065A – 650 V, 20 A, TO-220

650 & 1200 V IGBTs

- FGH75T65SQD – 650 V, 75 A, TO-247
- FGH50T65SQD – 650 V, 50 A, TO-274
- NGTB40N120FL3 – 1200 V, 40 A

Current Sense Amplifiers

- NCS210R – 26 V, 1% Gain Error, Amplifier
- NCS20074 – 3 MHz, Low Noise Op Amp

HV Auxiliary

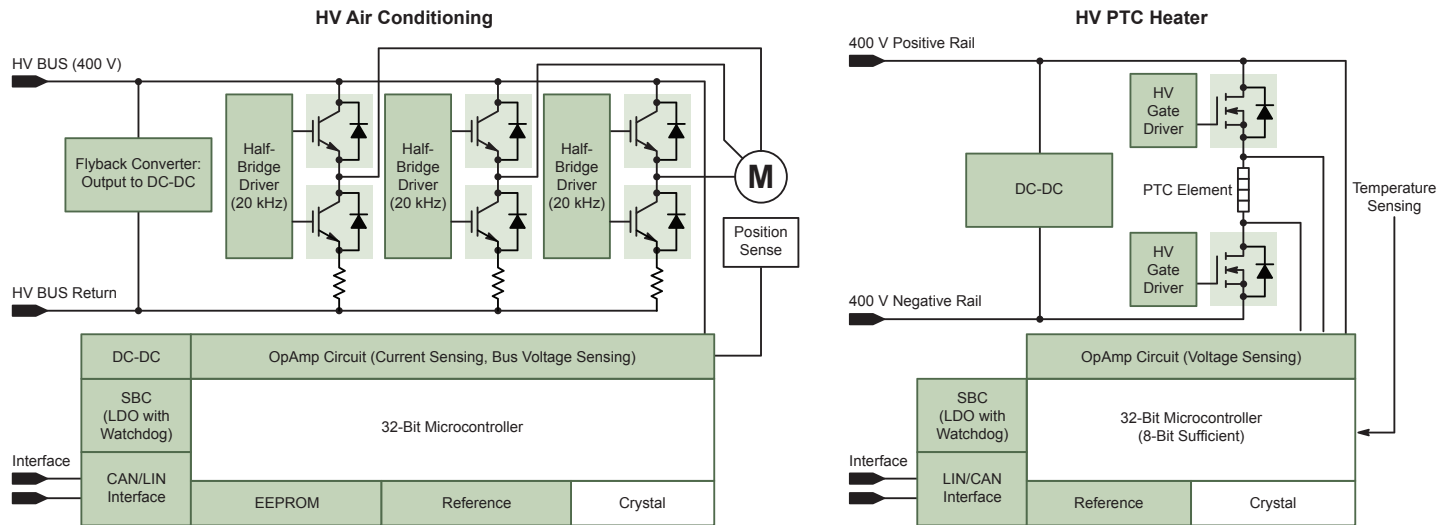

Key Products & Features

Discrete IGBTs: AFGHL40T65SPD, FGB/H40T65SPD-F085, FGH20/60N60UFDTU-F085, FGH40N65UFDTU-F085

- Low saturation voltage
- Fast switching
- Tight parameter distribution
- AEC-Q101 Qualified

High Voltage Gate Drivers: NCV570x, NCV51xx and FAN71xx-F085

- High drive current
- Short propagation delays
- Fault detection and reporting
- Designed for reliability
- AEC-Q100 Qualified

670 V Flyback Converters: NCV106x, NCV107x

- Enables compact designs for isolated and non-isolated systems
- Output power from 2 W to 15 W
- AEC-Q100 Qualified

HV IPM (ASPM): NFVA35065L32 (650 V/50 A) ; lineup 40 A / 30 A
NFVA23512NP* (1200 V/35 A) ; Line up 50 A/10 A

- AEC-Q100/101 qualified module & support AQG324
- 3-phase IGBT IPM with low loss IGBTs and soft recovery diodes optimized for auxiliary inverter in hybrid & electric vehicle applications
- Electrically isolated DBC substrate (AlN/Al₂O₃) with low thermal resistance (0.34°C/W & 650 V/50 A) and high isolation voltage (2.5 kVac)
- Adopted rugged Short Circuit Withstand Time FS Trench IGBT; over 5 μs & 400 V/175°C/15 V
- Integrated gate drivers with internal VS connection, under-voltage lockout, over-current shutdown, temperature sensing unit, and fault out

* Pending 4Q18.

HV-LV DC-DC Conversion

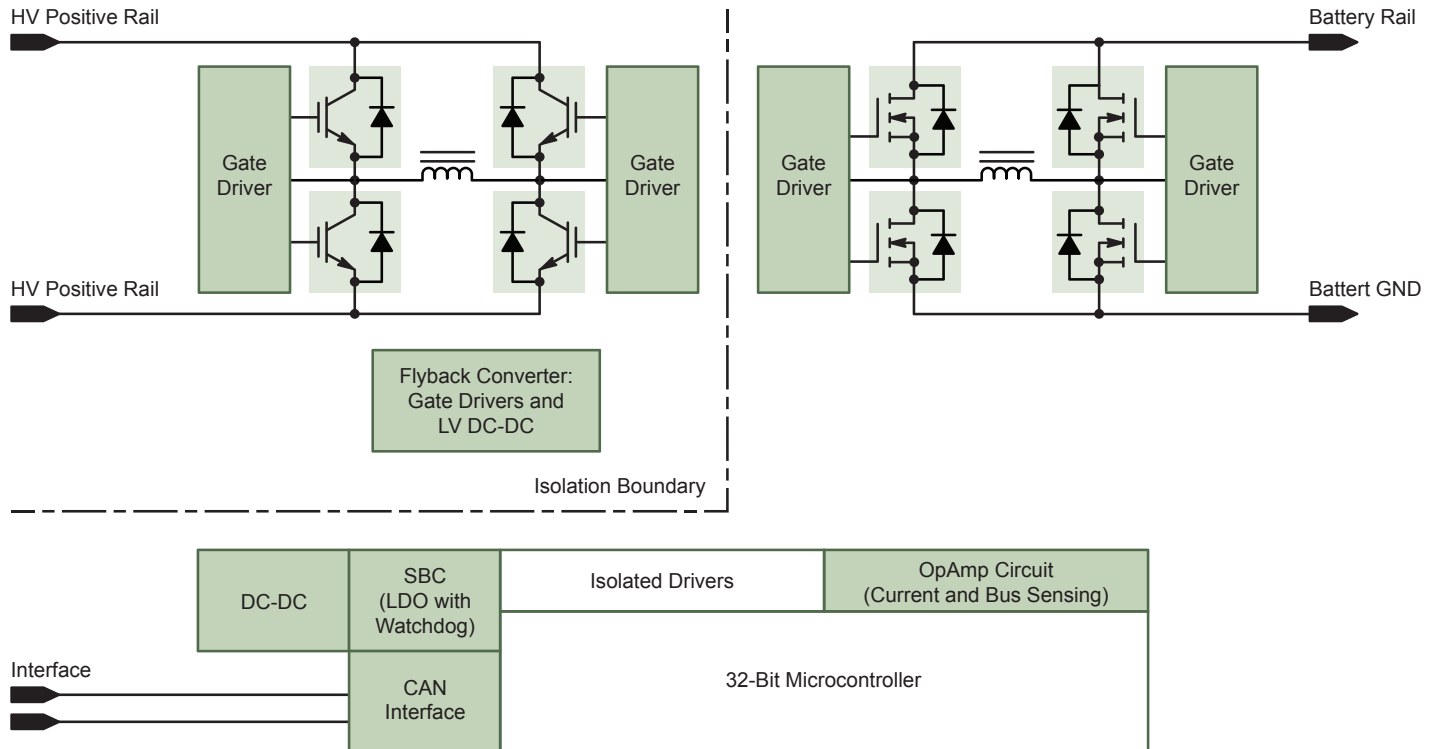

Key Products & Features

HV MOSFETs (SuperFET®): FCHxxN60F-F085, FCHxxN65F-F085

- Low on-resistance and low gate charge performance
- Low conduction loss
- Fast switching speeds
- Withstand extreme dv/dt rate and higher avalanche energy
- AEC-Q101 Qualified

High Voltage Gate Drivers: NCV570x, NCV51xx and FAN71xx-F085

- Family of rail-to-rail high current drivers for lower switching losses
- External (opto/silicon) or built-in galvanic isolation in multiple packages for design flexibility
- Short propagation delays for faster switching
- Signal conditioning and noise immunity for reliable operation
- AEC-Q100 Qualified

Discrete IGBTs: FGB/H40T65SPD-F085, FGH40/60N60SMD-F085, FGH40/60N60SFDTU-F085

- Fast switching
- AEC-Q101 Qualified

MV MOSFETs: FDBL863xx-F085, FDBL860xx-F085, NVMFS6H8xx

- Flat-lead performance packages (SO-8 FL & TOLL)
- Very low $R_{DS(ON)}$
- Small footprint, high current
- Superior reliability/robustness
- AEC-Q101 Qualified

670 V Flyback Converters: NCV106x, NCV107x

- Enables compact designs for isolated and non-isolated systems
- Output power from 2 W to 15 W
- AEC-Q100 Qualified

Traction Inverter for HEV/EV

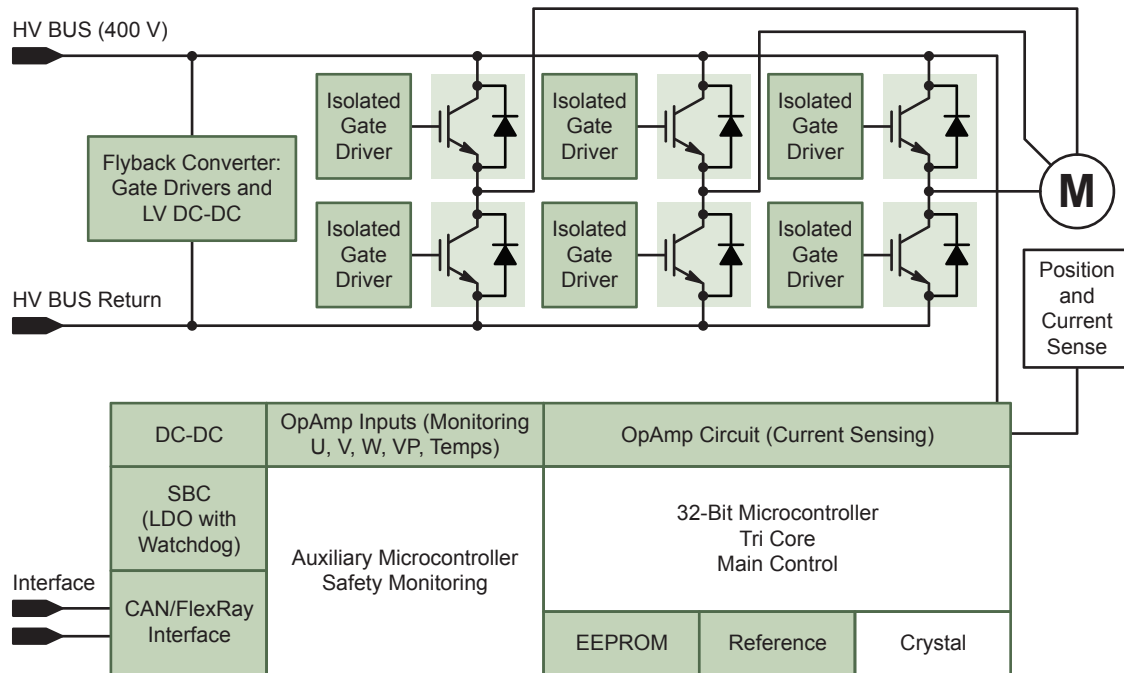

Key Products & Features

Discrete IGBTs: *FGY160T65SPD-F085, FGY120T65SPD-F085*

- Very low saturation voltage
- Tight parameter distribution
- 100% transient immunity tested
- Short circuit ruggedness > 6 μ s
- AEC-Q101 Qualified

High Voltage Gate Drivers: *NCV570x, NCV51705*

- Family of rail to rail high current drivers for lower system losses
- External (opto/silicon) or built-in galvanic isolation in multiple packages for design flexibility
- DESAT, Miller Clamp, TSD and fault reporting to prevent catastrophic failures
- Input signal conditioning and high noise immunity for reliable operation
- AEC-Q100 Qualified

IGBT Modules: *AHPM-DSC*

- Dual-side cooling for best in class power density & thermal performance
- Ultra low stray inductance (7 nH)
- On die temperature and current sense
- Best in class Trench Fieldstop IGBT with low recovery diodes

Bare Die IGBT and FRD: *PCGA300T65DF8(M1), PCGA200T65NF8(M1), PCGA160T65NF8, PCRKA300G5F8(M1), PCRKA200G5F8(M1), PCRKA160G5F8*

- Very low saturation voltage
- Ease of paralleling
- Monolithic Temperature Sensor and Current Sensor
- Solderable top metal available
- AEC-Q101 Qualified

670 V Flyback Converters: *NCV106x, NCV107x*

- Enables compact designs for isolated and non-isolated systems
- Output power from 2 W to 15 W
- AEC-Q100 Qualified

Smart Passive Sensors

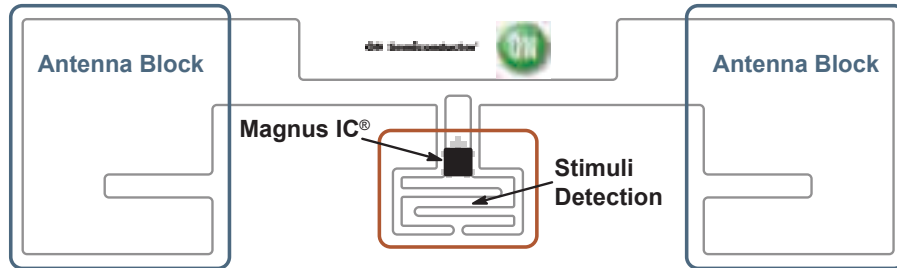

Features

- **Smart** – Magnus® sensor IC with adaptable RF front end
- **Passive** – UHF energy harvesting antenna blocks
- **Sensor** – Stimuli detection for temperature, moisture, pressure, & proximity

Automotive Benefits

- Safety
- Comfort
- Convenience
- Wire & weight reduction
- Improved fuel economy
- Highly scalable

Devices

- SPS1M001/M002 for moisture
- SPSXT001 for temperature
- SPSDEV1-8 for sensor reader hub

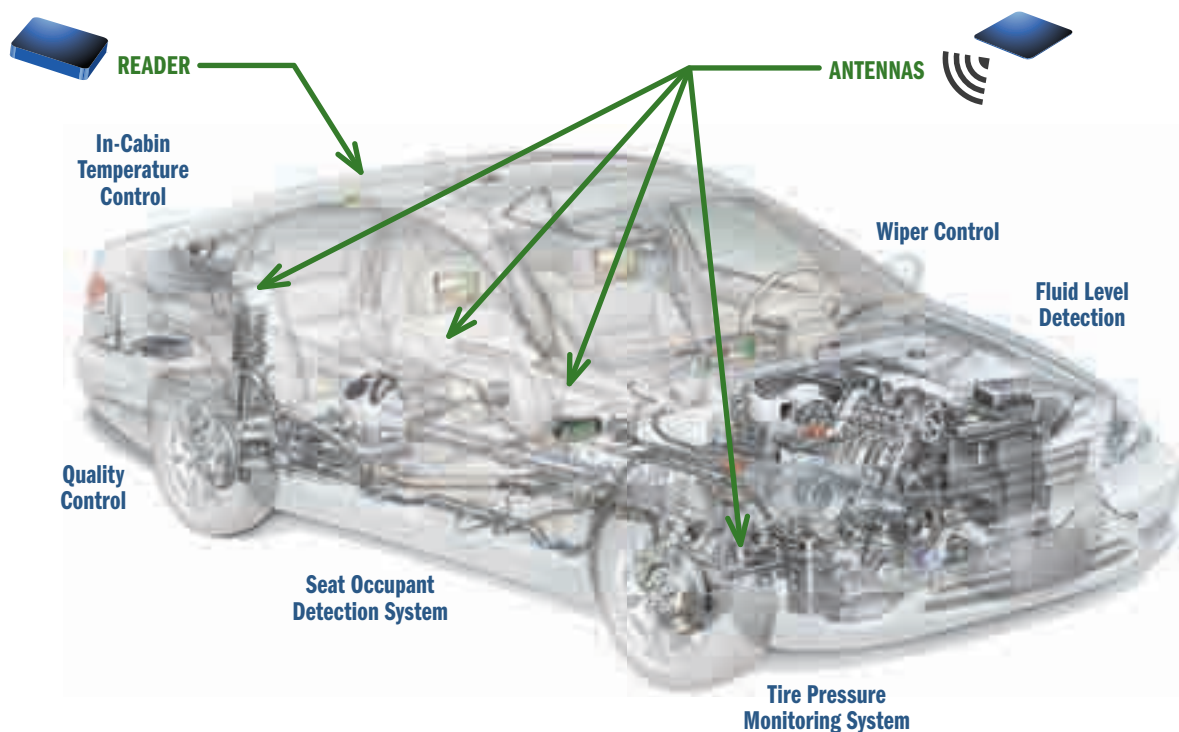

Capacitive Touch Sensors

LC717A capacitive touch sensors are high performance, cost-effective, highly usable capacitance converters for use in touch switch applications and replacing mechanical switches.

The LC717A30UJ has superior sensitivity performance, so it can detect hands with wearing multiple layers of gloves, and hands within 15 cm of distance. It can also perform gesture recognition.

Features

- Differential capacitive detection using mutual capacitance, to femto-Farad level
- High sensibility performance - even wearing multiple layers of gloves, air gap, or thick material
- High adaptability - calibration function, noise reduction, wide range temperature operation
- Design friendly - adhesive free, various circuit board (PCB/FPC) design, minimal external components
- 8 sensing inputs
- SPI/I2C interface control
- Voltage ranges of 2.6 - 5.5 V

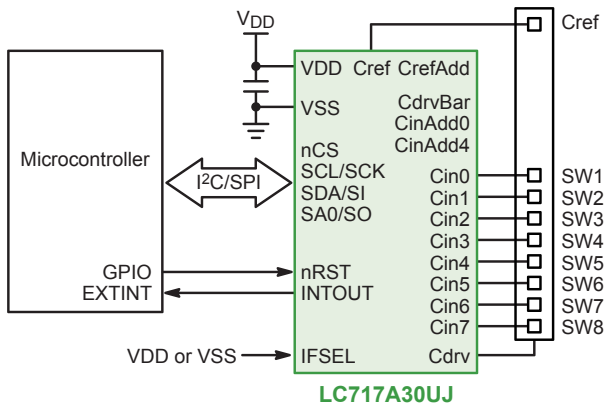

LC717A30UJ Application Diagram



LC717A30UJ Evaluation Kit



NIR-Enhanced Silicon Photomultipliers for Long Range Automotive LiDAR Applications

Features

- High responsivity of >100 kA/W @ 905 nm due to combination of high gain and detection efficiency
- PDE of >10 % at 905 nm
- Ultra-fast rise times and pulse widths from unique ‘fast output’ terminal
- Single photon sensitivity

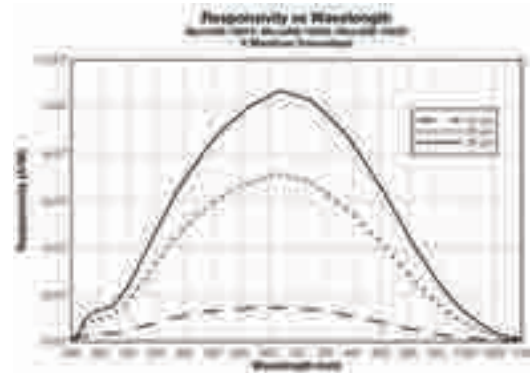

MicroRB sensors – 1 mm sensor in a robust molded leadframe package



ArrayRA – 1 x 16 monolithic array in a DFN package

Device	Description	Pixel Size (mm x mm)	Microcell (µm)	Package
Single Sensors				
MicroRB-10010-MLP	NIR-enhanced SiPM in a molded leadframe package	1 x 1	10	MLP
MicroRB-10020-MLP			20	
MicroRB-10035-MLP			35	
Monolithic Array				
ArrayRA-0116A20-DFN	Monolithic array of 1 x 16 NIR-enhanced SiPM pixels in a DFN package	0.49 x 0.17	20	DFN

Imaging Products for Automotive Applications

ON Semiconductor image sensors and co-processors enhance driver experience and safety. Since 2004, we have been the leading supplier of imaging solutions for human viewing (backup, surround view and night vision) and machine vision applications (ADAS – advanced driver assistance systems including lane departure warning, adaptive cruise control, pedestrian detection and more.) Recent innovations targeted at the automotive market optimize our products for these, and other emerging applications include smart headlights and driver monitoring.

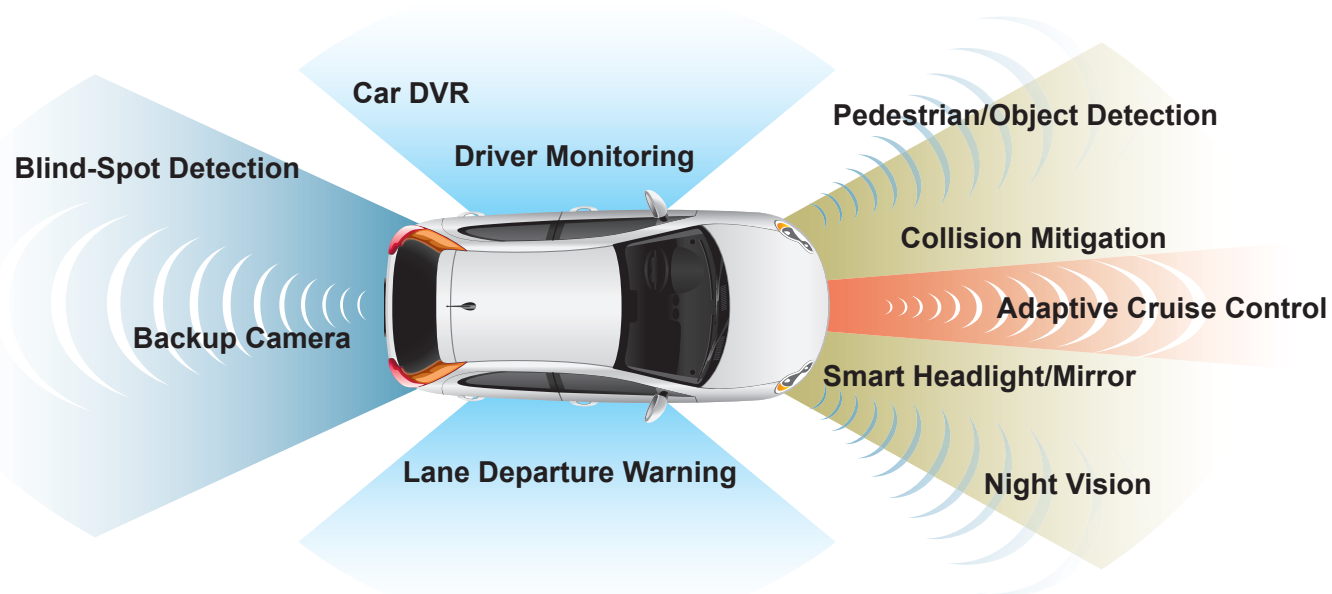

CMOS Image Sensors

Device	SOC ¹	Resolution (MP)	Optical Format	Frame Rate	Pixel Size (μm)	Shutter Type	CFA	Operating Temp (°C)
AR0140AT	Sensor	1	1/4"	60 fps	3	Electronic Rolling Shutter	Color	-40 to +105
AR0132AT	Sensor	1.2	1/3"	1.2 45 fps, 720p 60 fps	3.8	Electronic Rolling Shutter	Color, Mono, RCCC	-40 to +105
AR0135AT	Sensor	1.2	1/3"	60 fps @ 720p, 54 fps @ full res	3.8	Global Shutter	Mono	-40 to +105
AR0138AT	Sensor	1.2	1/2.6"	69 fps @ 720p	4.2	Electronic Rolling Shutter	RGB, RCCC	-40 to +105
AR0143AT	Sensor	1.3	1/4"	30 fps	3.0	Electronic Rolling Shutter	RGB, RCCB	-40 to +105
AR0220AT	Sensor	1.7	1/1.8"	60 fps	4.2	Electronic Rolling Shutter	RGB, RCCC, RCCB	-40 to +105
AR0230AT	Sensor	2	1/3"	30 @ fps 1080p	3.0	Electronic Rolling Shutter	Mono, RGB	-40 to +105
AR0231AT	Sensor	2.3	1/2.7"	60 fps full res @ 2 exp, 40 fps full res @ 3 exp	3.0	Electronic Rolling Shutter	RGB	-40 to +125
AR0233AT	Sensor	2.6	1/2.5"	60 fps	3.0	Electronic Rolling Shutter	RGB, RCCB	-40 to +105
AR0234AT	Sensor	2.3	1/2.6"	120 fps	3.0	Global Shutter	Mono, RGB	-40 to +85
AR0237AT	Sensor	2.1	1/2.7"	60 fps	3.0	Electronic Rolling Shutter	RGB	-40 to +105
AR0820AT	Sensor	8.3	1/2"	40 fps	2.1	Electronic Rolling Shutter	RGB, RCCC, RCCB	-40 to +105
ARX550AT	Sensor	VGA	1/5"	66.37 fps @ full res	3.8	Electronic Rolling Shutter	RGB	-40 to +105
MT9V024	Sensor	WVGA	1/3"	60 fps	6.0	Global Shutter	Color, Mono, RCCC	-40 to +105
AS0140AT	SOC	1	1/4"	60 fps	3.0	Electronic Rolling Shutter	RGB	-40 to +105
ASX340AT	SOC	VGA	1/4"	60 fps digital, 30 fps analog	5.6	Electronic Rolling Shutter	Color	-40 to +105
ASX342AT	SOC	VGA	1/4"	50/60 fps	5.6	Electronic Rolling Shutter	RGB	-40 to +105
ASX344AT	SOC	VGA	1/4"	60 fps NTSC, 50 fps PAL interlaced, 60 fps progressive	5.6	Electronic Rolling Shutter	RGB	-40 to +105
ASX350AT	SOC	VGA	1/5"	60 fps digital, 30 fps analog	3.8	Electronic Rolling Shutter	Color	-40 to +105

1. See description on page 19.

Co-Processors for Image Sensors

Available Features

- High Dynamic Range with Adaptive Local Tone Mapping
- Dewarp, up to 165 degrees
- Spatial Transform Engine Software Add-on
- Overlays
- GPIOs, up to 7
- Color Pipe
 - Demosaic
 - Gamma correction
 - Auto white balance
 - Defect correction
- Noise reduction
- Auto exposure
- Flicker detection

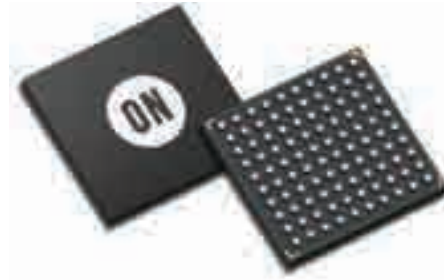

Image Co-Processors

Device	Maximum Resolution	Supported Sensors	Frame Rate	HDR with ALT	Dewarp	Spatial Transform Engine Software Add-on	Overlays	GPIOs	Sensor Interfaces	Output Interfaces	Input Clock (MHz)	Output Clock	Operating Temp (°C)	Package
AP0100	1.2 MP	ARO132AT, ARO140AT, ARX550AT	1.2 MP 45 fps 720p60	YES	YES, Up to 165°	YES, Multiple viewing options, PTZ	YES	Up to 5	2-Lane HiSPi, 12-bit parallel	NTSC/PAL, 16-bit parallel	6-30	27 MHz (NTSC/PAL) 84 MHz parallel	-30 to +70 (CS Version) -40 to +105 (AT Version)	VFBGA-100
AP0101	1.2 MP	ARO132AT, ARO140AT, ARX550AT	1.2 MP 45 fps	YES	NO	NO	NO	Up to 5	12-bit parallel	16-bit parallel	6-30	84 MHz parallel	-30 to +70 (CS Version) -40 to +105 (AT Version)	VFBGA-81
AP0102AT	2.0 MP	ARO132AT, ARO140AT, ARO136AT	30 fps @ 1080p, 45 fps @ 1.2Mp, 60 fps @ 720p	YES	NO	YES	YES	Up to 7	Parallel and HiSPi	Up to 24-bit parallel	6-30 MHz	125 MHz	-40°C to +105°C	VFBGA-100
AP0200AT	2.0 MP	ARO132AT, ARO136AT, ARO140AT, ARO230AT	30 fps @ 1080p, 45 fps @ 1.2Mp, 60 fps @ 720p	YES	NO	YES	YES	Up to 7	12-bit Parallel and HiSPi	Ethernet-MII, RMII, GMII	10-29 MHz	125 MHz	-40°C to +105°C	VFBGA-100
AP0201AT	2.0 MP	ARO132AT, ARO136AT, ARO140AT, ARO230AT	30 fps @ 1080p, 45 fps @ 1.2Mp, 60 fps @ 720p	YES	NO	NO	NO	Up to 7	12-bit Parallel and HiSPi	Ethernet-MII, RMII, GMII	10-29 MHz	125 MHz	-40°C to +105°C	VFBGA-100
AP0202AT	2.0 MP	ARO132AT, ARO136AT	30 fps @ 1080p, 45 fps @ 1.2Mp, 60 fps @ 720p	YES	NO	NO		Up to 7	12-bit Parallel and HiSPi	Up to 24-bit Parallel	10-29 MHz	125 MHz	-40°C to +105°C	VFBGA-100

SOC Processing Functionality

- Optimized for use with HDR (High Dynamic Range) sensors
- Full auto-functions support (AWB and AE) and ALT (Adaptive Local Tone Mapping) to enhance HDR images
- Next generation color pipe with improved noise filtering & reduced chromatic aliasing
- Spatial Transform Engine (STE) with dual transform support
- Picture in Picture support for advanced backup cameras
- Pre-rendered Graphical Overlays
- Multi-Camera synchronization support
- LED flicker detection and avoidance

Modular Automotive Reference System

The Modular Automotive Reference System (MARS) is a complete imaging solution for camera system developers and software developers working on automotive imaging applications. MARS gives engineers and software developers the fundamental building blocks needed to create next generation imaging systems, while reducing the design effort and resources required to develop a working solution.

Using the modular mix & match approach offered by this unique compact form factor platform, designers can bring together different combinations of image sensors, co-processors (Image Signal Processor) and communication standards. The component boards have consistent signal/power interconnect definitions to enable users to swap individual boards, creating a wide range of options for experimenting, while eliminating the need for constructing custom boards. The result is a highly flexible solution where the various modules are fully interchangeable.

For videos, tools and more information visit www.onsemi.com/MARS

Features

- Ready to use camera solution
- Compact form factor
- Modular and interchangeable building blocks
- Supported by comprehensive ecosystem
 - Software development platforms
 - Lens partners
 - Schematic, gerbers, BOM

Benefits

- Accelerates development cycles
- Reduces need for technical resources
- Reduces development costs
- Eliminates redundant work



Modular Automotive Reference System

- ADAS
- Autonomous driving
- Viewing systems
- Backup cameras
- Surround view systems
- Electronic mirrors
- In-cabin cameras for
 - Gesture recognition
 - Driver eye monitoring
 - Light level inspection

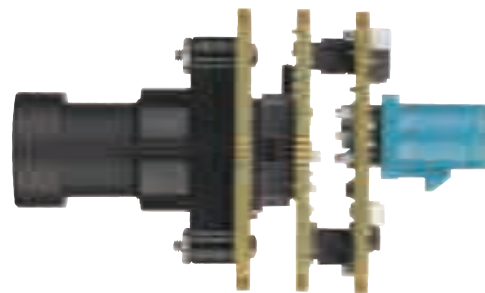

Individual MARS Board Order Descriptions

Sensor Board OPNs	Short Description	Sensor Board Description
MARS1-AR0230ATS-GEVB	2.1 MP, 1/2.7" MARS Sensor Board	MARS sensor board with 2.1 MP, 1/2.7" high-dynamic range color AR0230AT image sensor
MARS1-AR0231AT6-GEVB	2.3 MP, 1/2.7" MARS Sensor Board	MARS sensor board with 2.3 MP, 1/2.7" high-dynamic range color AR0231AT image sensor with LED Flicker Mitigation and BSI pixel technology for superior low-light performance
MARS1-AR0132AT6-GEVB	1.2 MP, 1/3" MARS Sensor Board	MARS sensor board with 1.2 MP, 1/3" high-dynamic range color AR0132AT image sensor
MARS1-AR0136AT3-GEVB	1.2 MP, 1/3" MARS Sensor Board	MARS sensor board with 1.2 MP, 1/3" high-dynamic range color AR0136AT image sensor and BSI pixel technology
MARS1-AR0140AT3-GEVB	1.0 MP, 1/4" MARS Sensor Board	MARS sensor board with 1.0 MP, 1/4" high-dynamic range color AR0140AT image sensor
MARS1-AR0135AT2-GEVB	1.2 MP, 1/3" MARS Sensor Board	MARS sensor board with 1.2 MP, 1/3" global shutter AR0135AT image sensor with high global shutter efficiency and superior NIR performance
Co-Processor Board OPNs		Image Co-Processor Description
MARS1-AP0200AT2-GEVB	Up to 2.0 MP MARS Image Co-processor Board	MARS Image Co-Processor (ICP)AP0200AT High-Dynamic Range (HDR) ICP with built-in MJPEG and H.264 encoder and Ethernet-MII, RMII, GMII output interface
MARS1-AP0202AT2-GEVB	Up to 2.0 MP MARS Image Co-processor Board	MARS Image Co-Processor (ICP) with AP0202AT High-Dynamic Range (HDR) ICP with parallel output
MARS1-AP0100AT2-GEVB	Up to 1.2 MP MARS Image Co-processor Board	MARS Image Co-Processor (ICP) with AP0100AT High-Dynamic Range (HDR) ICP with sophisticated lens distortion correction and integrated video encoder for NTSC/PAL output
MARS1-AP0101AT2-GEVB	Up to 1.2 MP MARS Image Co-processor Board	MARS Image Co-Processor (ICP) with AP0101AT High-Dynamic Range (HDR) ICP and parallel output
MARS1-AP0102AT2-GEVB	Up to 1.2 MP MARS Image Co-processor Board	MARS Image Co-Processor (ICP) with AP0102AT High-Dynamic Range (HDR) ICP with sophisticated lens distortion correction and parallel output
Serializer OPNs		Serializer Description
MARS1-TI913-GEVK	MARS Serializer Board	Texas Instruments DS90UB913 Parallel to LVDS FPD-Link Serializer
MARS1-MAX96705-GEVB	MARS Serializer Board	Maxim MAX96705 Parallel to LVDS GMSL Serializer
Deserializer OPNs		Deserializer Description
MARS1-TI914	MARS Deserializer Board	Texas Instruments DS90UB914 LVDS to Parallel FPD-Link Deserializer
MARS1-MAX9706	MARS Deserializer Board	Maxim MAX96706 LVDS to Parallel GMSL Deserializer
Ethernet PHY OPNs		Ethernet PHY Description
MARS1-KSZ8081MNX-GEVB	MARS Ethernet PHY Board	MARS Micrel KSZ8081MNX-GEVB Ethernet PHY Board
Demo3 Adapter Board OPNs		Demo3 Adapter Board Description
MARS1-DEMO3-ADAPTER-GEVB	MARS Parallel to Demo3 Adapter	MARS Adapter for adapting the parallel serializer boards into Demo3 Demo Kit Tool
Demo3 Board OPNs		Demo3 Board Description
AGB1NOCS-GEVK	Demo3	Demo3 Demo Kit Tool

Automotive Lighting Systems



ON Semiconductor offers standard products and custom devices for automotive lighting applications. The company plays a prominent role in the market for Xenon driver ASICs, developed the defacto standard stepper driver for headlight leveling and swiveling, and is a leader in LED exterior lighting solutions.

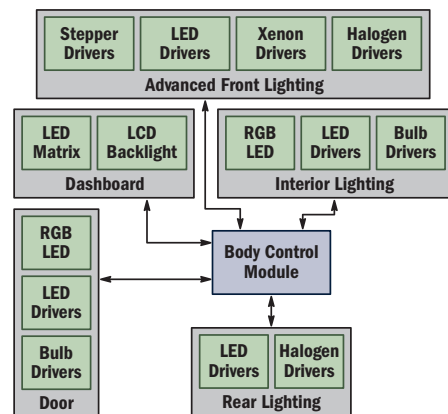

Front Lighting

The majority of automobiles on the road today are equipped with halogen lights for the high-beam (HB) and low-beam (LB) functions - the main front lighting functions. Halogen LB typically consumes 55 W, and provides ~1,000 lumen. HID technology - introduced over ten years ago - consumes 35 W, and provides ~3,500 lumen. Because of the high intensity and risk of glare to approaching traffic, some countries require automatic leveling of the LB, plus a high pressure cleaning device. Over time, HID lights will integrate the HB function into bi-xenon solutions.

While halogen technology continues to be viable for front lighting, automotive designs increasingly use LED lighting. LED lighting offers enhanced styling options, enables 'instant-on' lighting, and allows brightness control from 0% to 100% power.

Another important aspect for automotive front lighting is beam swiveling for Advanced Frontlighting Systems (AFS), to optimize the

visibility in curves, and Adaptive Driving Beam (ADB), to adapt the beam to real-time situations. Stepper motors provide the primary controls for AFS and ADB.

ON Semiconductor offers a full range of products, from generic bulb driver solutions to stepper drivers, LED drivers, and Xenon drivers, that are specifically designed for front lighting.

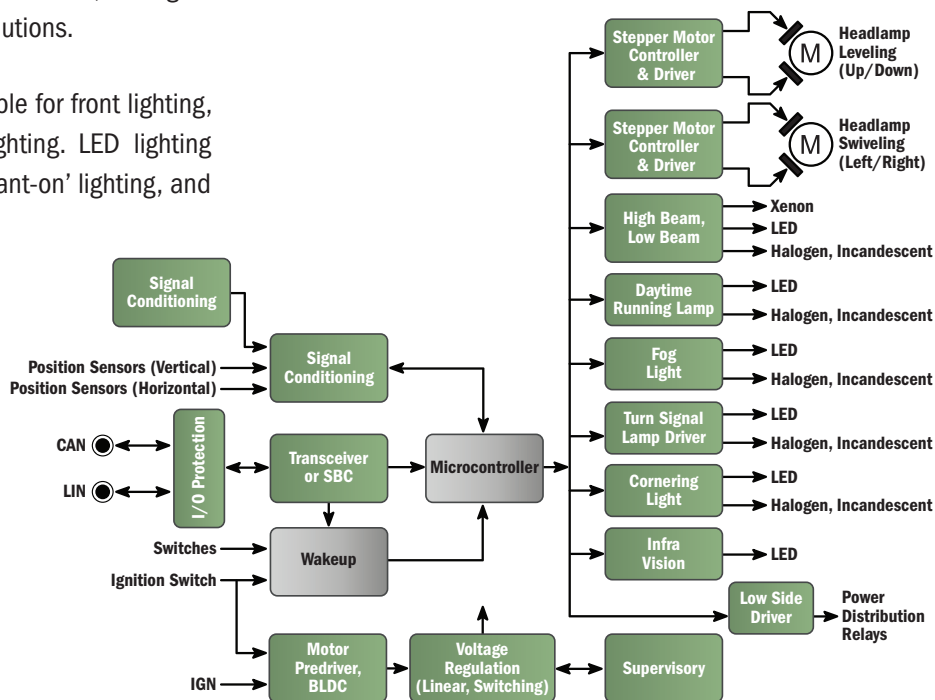

Front Lighting – Power Ballast and Dual LED Driver for Advanced LED

The NCV78763 single-chip, intelligent LED driver for front lighting enables single-module control of high beams, low beams, daytime running lights, position lights, cornering lights, turn indicators, and fog lights. With integrated digital dimming, SPI

programmable settings, and build-in diagnostics, the NCV78763 offers integrated, energy efficient solutions for comprehensive front lighting control.

Features - NCV78763

- System integrated solution with few external components.
- Buck-boost topology
- LED current regulator
 - Constant average current
 - Efficient integrated buck switches (high-side)
 - Current per output up to 1.6 A
 - Extended diagnostics: detection of open circuit or failing driver, short, over-current protection, single LED failures
 - Thermal protection
- System customization by SPI interface
 - Multiple system configurations with one device
 - Fewer module versions for OEM
- Better EMC behavior, without extra filtering
 - Low EMC from battery
 - Low EMC to LED string
- High overall efficiency (>90%)

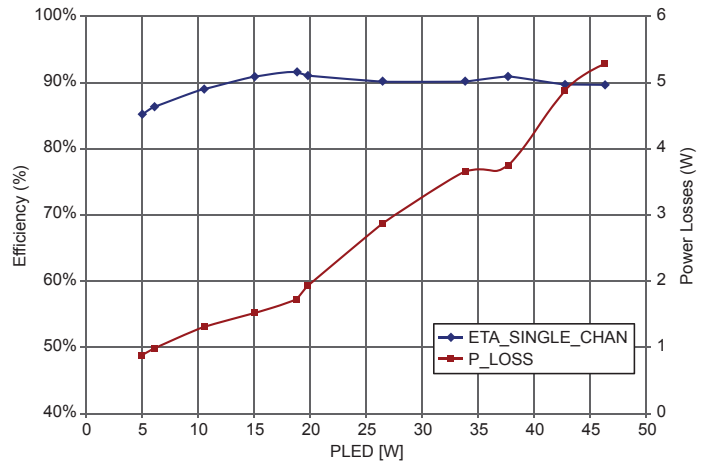

NCV78763 Demonstration Board Efficiency



Demonstration Kit

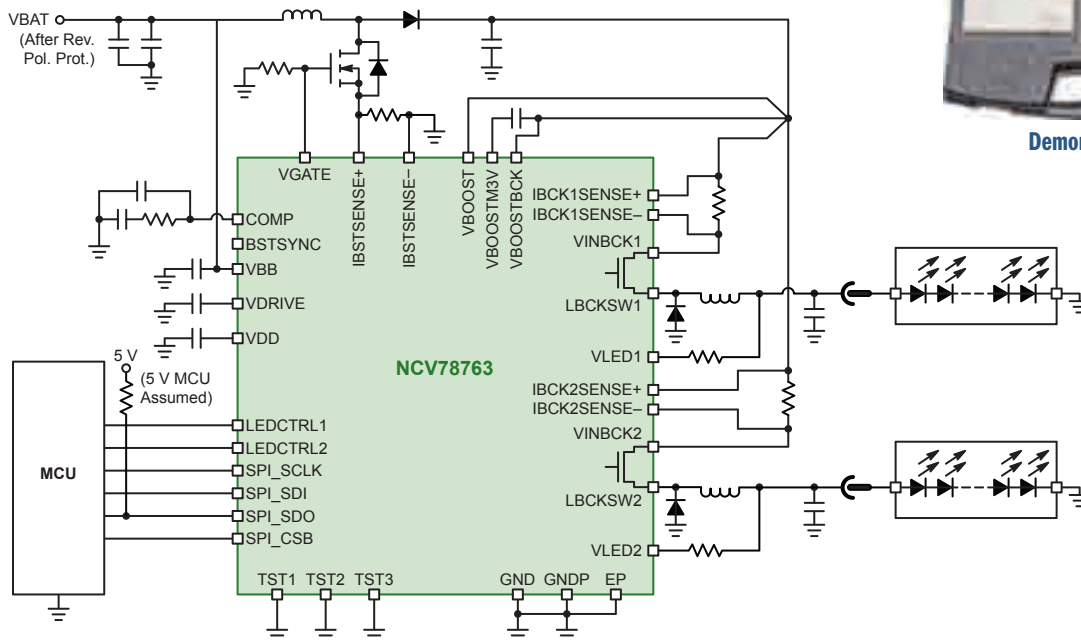

NCV78763 Application Diagram



LIGHTING

Front Lighting – Leveling and Swiveling

The NCV70628 is a single-chip micro-stepping motor driver with position controller and control/diagnostic interface, making it

ideal for dedicated mechatronics solutions, connected remotely through a LIN master.

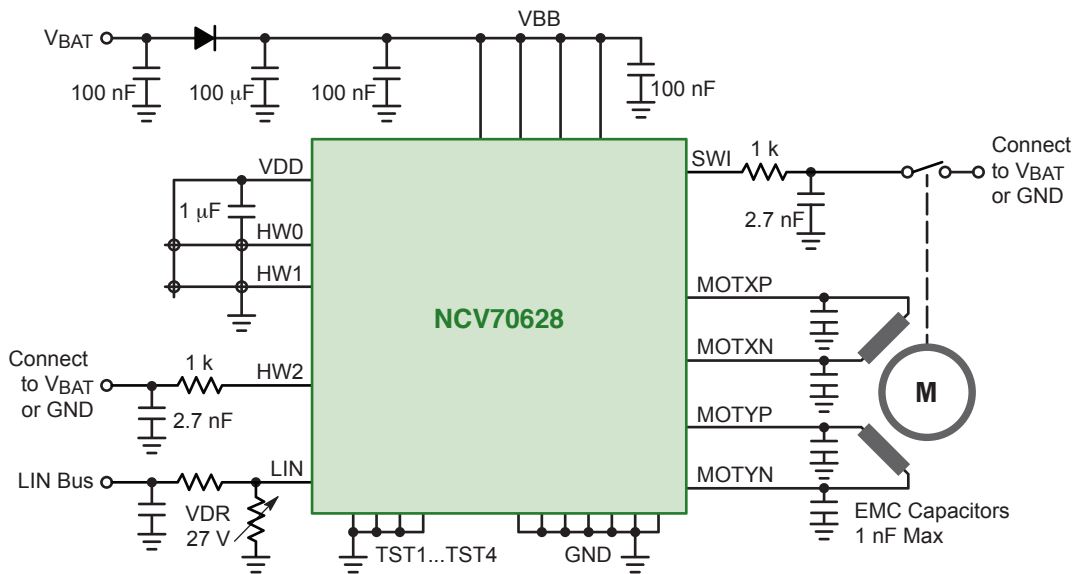

The NCV70514 is a micro-stepping motor driver that is fully compatible with automotive voltage requirements, and is

especially well-suited for use in applications with fluctuating battery supplies.

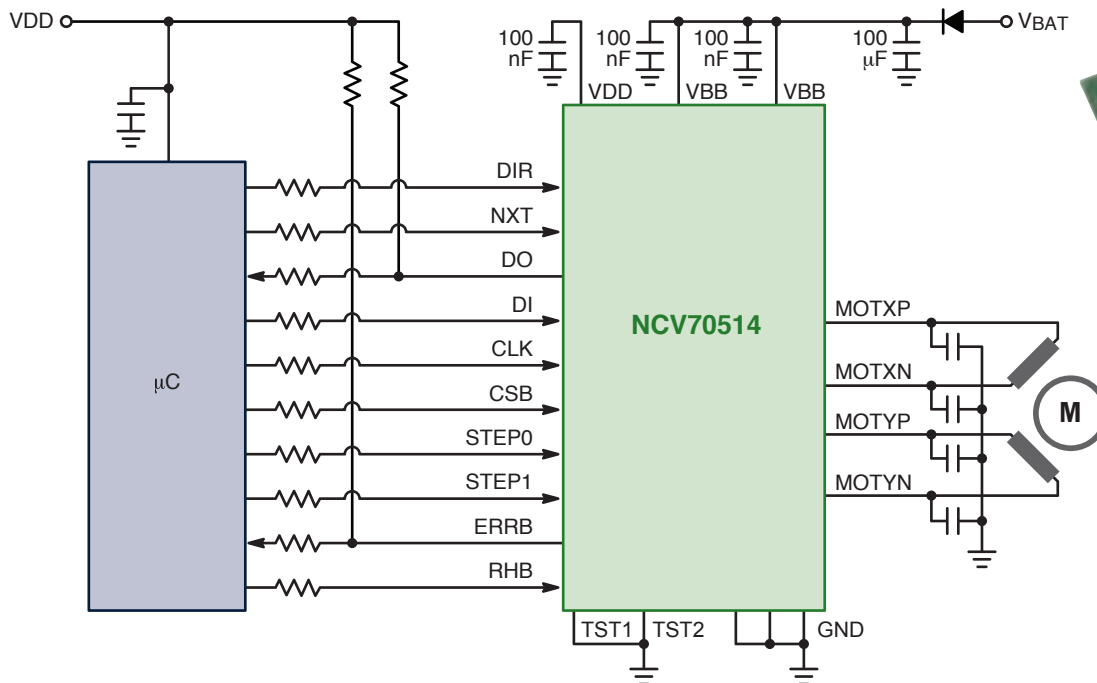

Evaluation Board
NV705143R1DBGVB

LIGHTING

Front Lighting – Small Signal Solutions for Pixel (Matrix) Control

Today's adaptive front lighting systems (AFLS) utilize a combination of sensors, motors, and a LED matrix to adjust the direction and intensity of the light beam. One AFLS method involves blanking of certain LED strings within the matrix, which can be controlled by a combination of small signal components such as Low $V_{CE(sat)}$ bipolar transistors and digital transistors (BRT – bias resistor transistor).

The collector of the NPN digital transistor is connected to the base of the Low $V_{CE(sat)}$ PNP transistor, thereby forming an ultra-low saturation voltage ($V_{CE(sat)}$) and high current gain capability of the combination. The high current gain allows this combination to be driven directly from an MCU or PMU's control outputs, reducing overall system complexity and cost.



Features

- AEC-Q101 discrete & Mixed Element Array (MEA) components
- Low $V_{CE(sat)}$ ensures shunting of LED
- Simplifies circuit design & reduces component count
- PCB space saving with 2 mm x 2 mm wettable flank DFN packaging

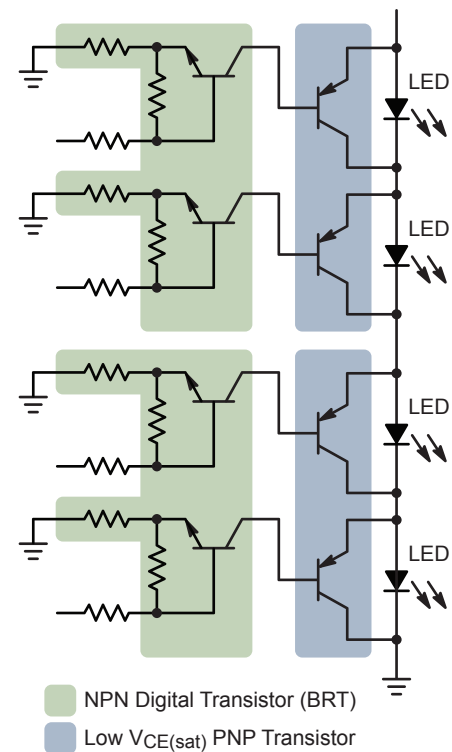

Device	V_{CE0} (V)	I_c (A)	$V_{CE(sat)}$ (V)	Description	Package(s)
NSV60100DMTW	-60	1.0	-0.35	60 V, 1 A Dual PNP Low $V_{CE(sat)}$ BJT	WDFN-6 WF
NSV60200DMTW	-60	2.0	-0.45	60 V, 2 A Dual PNP Low $V_{CE(sat)}$ BJT	
NSV20200DMTW*	-20	2.0	-0.39	20 V, 2 A Dual PNP Low $V_{CE(sat)}$ BJT	SC-88 (SOT-363)
NSVMUN5214D	50	0.1	0.25	Dual NPN BRT, R1 = 10k Ω , R2 = 47k Ω	
NSVM602002214DMTW*	-60	2.0	-0.45	60 V, 2 A MEA - Dual (NPN BRT + PNP Low $V_{CE(sat)}$ BJT)	WDFN-6 WF
NSVM202002214DMTW*	-20	2.0	-0.39	20 V, 2 A MEA - Dual (NPN BRT + PNP Low $V_{CE(sat)}$ BJT)	

* Pending 4Q18.

Rear Lighting – Linear LED Pre-Driver

NCV7691 is a pre-driver intended for linear drive of LEDs. It can operate from the car battery and multiple LED strings can be driven by a single NCV7691 device.

Features – NCV7691

- Constant Current Output for LED String Drive External Programming Current Resistor
- Wide Current Range using External Bipolar Device
- Multiple LED String Control
- Pulse Width Modulation (PWM) Control
- Negative Temperature Coefficient (NTC) Current Control
- Open LED String & Short-Circuit LED String Diagnostic
- Overvoltage Set Back Power Limitation
- SOIC-8 Package
- AEC-Q100 Qualified and PPAP Capable

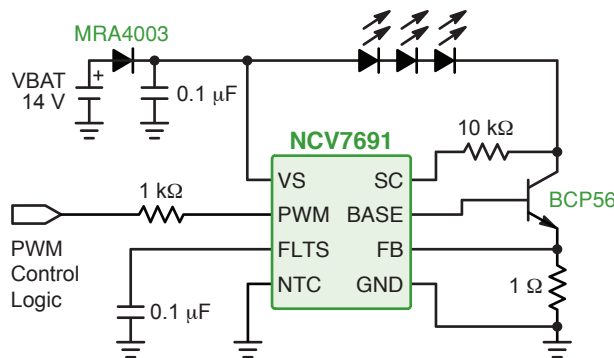
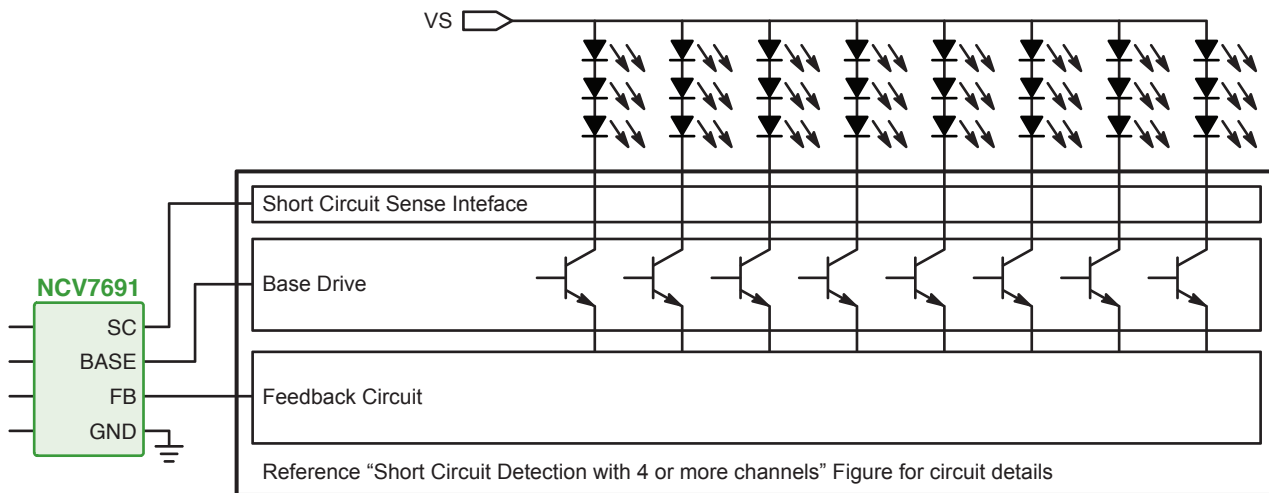

Rear Lighting – Linear Current Regulators/Controllers

For Rear Combination Lamps, Daytime Running Lights, Fog Lights, CHMSLs, Turn Signals

The NCV7680, NCV7681, and NCV7683 are 8-channel linear programmable constant current sources, designed for the regulation and control of LED-based lighting.

- Allow for two programmed levels for Stop and Tail illumination, or optional external PWM
- Slew rate control to eliminate EMI concerns
- Sequencing functionality (NCV7683)

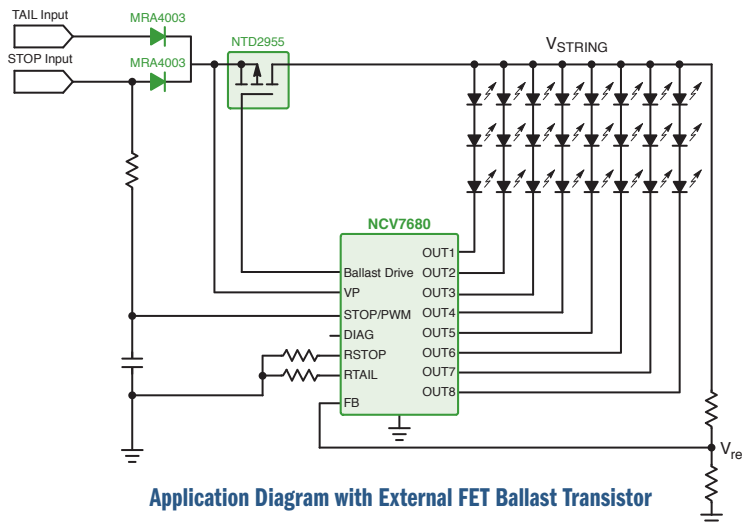

The NCV7684 is a 12-channel linear programmable constant current sources, designed for the regulation and control of LED-based lighting.

- Allow for 128 current levels, adjustable with I2C-programmable PWM
- 3.3 V voltage reference for loads up to mA
- OTP back for stand-alone operation (2 configurations)

Device	Channels	V _I Max (V)	I _O Max (mA)	Max LEDs in Series	Max LEDs in Parallel	Package(s)
NCV7680	8	45	75	1	16	SOIC-16 WB EP
NCV7681	8	40	100	3	8	SOIC-16 WB EP
NCV7683	8	40	200	4	24	SSOP24 NB EP
NCV7684	12	40	60	3	12	SSOP24 NB EP

Interior Lighting – LIN RGB LED Driver

The LIN Bus (Local Interconnect Network) is an inexpensive serial communications protocol, which is used within current automotive network architectures. It is a relatively slow communication system intended to monitor sensor devices or actuators in today's cars.

The NCV7430, LIN RGB LED Driver, combines a LIN transceiver together with a RGB LED driver and memory. It is a single-chip RGB driver intended to monitor for dedicated multicolor LED applications in automotive interior lighting. It contains a LIN interface (slave) for parametric programming of LED color and

intensity. The device receives instructions through the LIN bus and subsequently drives the LEDs independently.

The NCV7430 acts as a slave on the LIN bus and the master can request specific status information (parameter values and error flags). The LIN address of the NCV7430 can be programmed in the internal memory of the device.

The NCV7430 is fully compatible with automotive requirements.

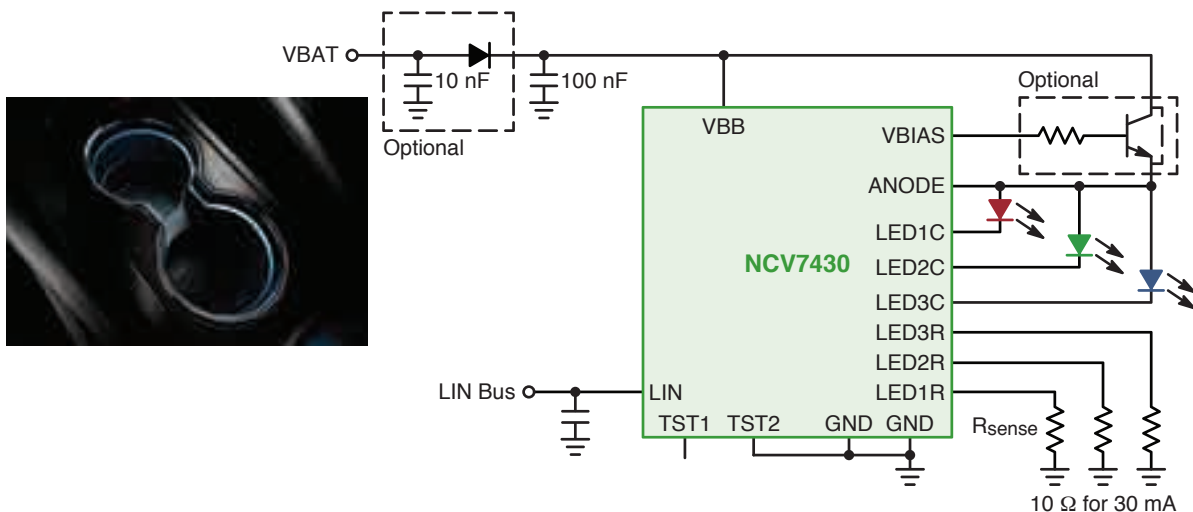

Features – NCV7430

RGB LED Driver

- 3 independent LED current regulators
- LED currents programmable with external resistors
- Power dissipation option with external ballast transistor
- LED temperature compensation with external sense circuit
- Modulation control for 3 LEDs (with calibration)

LIN Interface

- LIN physical layer according to LIN 2.1/SAE J2602
- OTP-programmable device node number and group address
- Diagnostics and status information about LEDs
- Supports auto-addressing

Protection and Diagnostics Over-Current Detection

- Short circuit detection to GND and VBB
- Open LED detection
- High temperature warning and shutdown
- Retry mode on error detection

Power Saving

- Sleep mode supply current 20 μ A
- Compliant with 14V automotive systems

EMI Compatibility

- LIN Bus integrated slope control
- EMC reduced LED modulation mode

Interior Lighting and Center High Mount Stop Lamp (CHMSL) – Constant Current Regulators

The two-terminal linear constant current regulators (CCRs) are simple, economical, and robust devices that provide an effective solution for regulating current in cost-sensitive LED applications. The devices require no external components, allowing them to be implemented as high or low-side regulators. These

devices regulate output current over a wide range of input voltage, and are designed with a negative temperature coefficient to protect LEDs from thermal runaway at extreme voltage and operating temperature.

Features

- Regulated current provides constant brightness over wide voltage range
- Negative temperature coefficient protects LEDs in high ambient conditions
- Available with multiple maximum operating voltages (45 V, 50 V, and 120 V) to withstand battery load dump

Resources

- Sample Kit: CCR2KIT/S

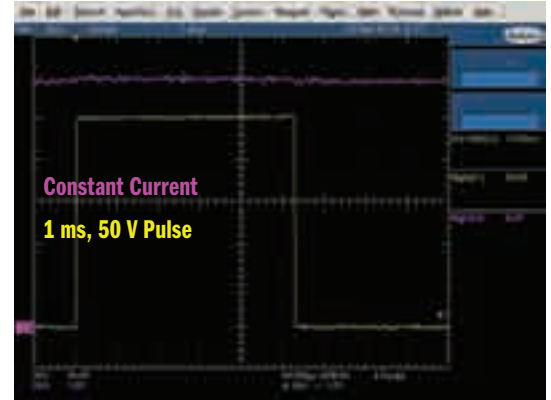
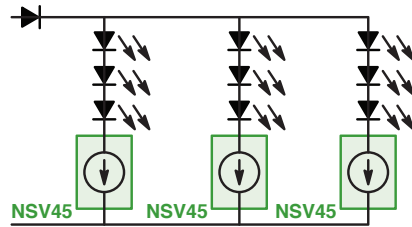

Constant Current Supply During Vehicle Battery Load Dump

Device	Max Anode-to-Cathode Voltage (V _{AK}) (V)	Voltage Overhead (V _{in} - V _{LEDs}) (V)	Constant Current I _{reg} (@ V _{AK} = 7.5 V) (mA)	Current Tolerance Over Voltage	Max Junction Temperature (°C)	Packages
NSV45xxx	45	1.8	Fixed: 15, 20, 25, 30	±15%, ±10%	150	SOD-123, SOT-223
NSV50xxx	50	2.0	Fixed: 10, 350	±10%	175	SMC, DPAK
NSVC20xx	120	1.8	Fixed: 20, 30, 50	±15%	175	SMB
NSV45xxxJ	45	1.8	Adjustable: 20 to 40, 35 to 70, 60 to 100, 90 to 160, 150 to 350	±15%	150	SOT-223, DPAK

NOTE: xxx in the device number represents the current level.



LCD Drivers for Information Display Panels

Features

- LCD driver (common drive and segment drive) controlled by external microprocessor
- Serial data input supports CCB format communication
- Many additional functions around the display application
 - Key input function
 - LED driver output port
 - General purpose output port
 - PWM output function for brightness adjustment of the backlight
 - LCD display contrast adjustment
- Wide operating temperature ($T_A = -40$ to $+85/+105$ °C)

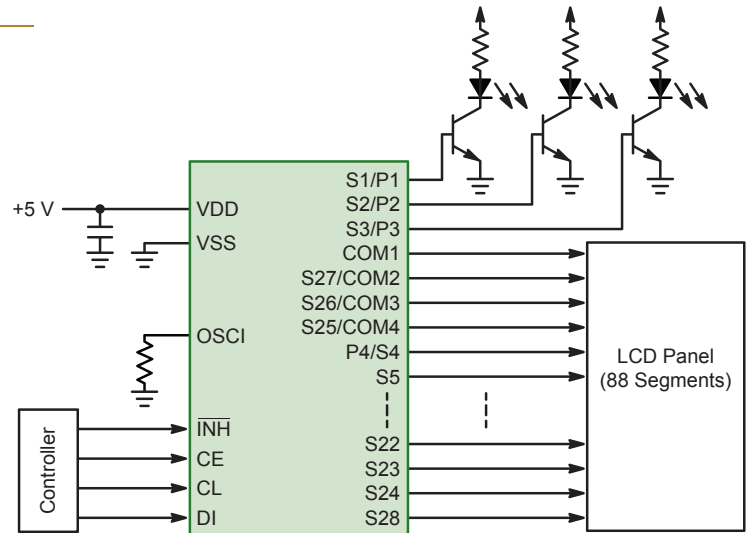

LC75843 Application Diagram, 1/4 Duty, 3-Channel PWM

Device	Segments*			V _{DD} (V)	Interface Voltage (V)	V _{LCD} (V)	Output Ports	PWM Channels	Package(s)
	Static, 1/2 Duty	1/3 Duty, 1/4 Duty							
LC75843	24 to 28, 46 to 54	66 to 78, 84 to 100		4.0 - 6.3	3.3 or 5.0	V _{DD}	4	3	TSSOP-36
	1/3 Duty	1/4 Duty							
LC75897	363 to 387	480 to 512		2.7 - 6.0	V _{DD}	2.7 - 6.0	8	3	SQFP-144
LC75879	183 to 207	240 to 272		4.5 - 6.3	3.3 or 5.0	V _{DD}	8	3	TQFP-80J
LC75829	147 to 159	192 to 208		4.5 - 6.0	3.3 or 5.0	V _{DD}	4	–	SQFP-64
LC75806	198 to 231	260 to 304		4.5 - 6.0	3.3 or 5.0	V _{DD}	9	–	TQFP-100
	1/8 Duty	1/9 Duty	1/10 Duty						
LC75818	Dot matrix (5 x 7) x 16 + 80	Dot matrix (5 x 8) x 16 + 80	Dot matrix (5 x 9) x 16 + 80	2.7 - 3.6	3.3 or 5.0	4.5 - 10.0	4	–	TQFP-120
LC75812	Dot matrix (5 x 7) x 13 + 65	Dot matrix (5 x 8) x 12 + 64	–	2.7 - 3.6	3.3 or 5.0	4.5 - 10.0	3	3	TQFP-100
	Static, 1/2 Duty	1/3 Duty, 1/4 Duty	LED Driver						
LC75805	38, 74	108, 140	48 Channels	4.5 - 5.5	V _{DD}	V _{DD}	–	7	QIP-100E

* Number of segments depends on 'common v segment' configuration.



In-Vehicle Networking Solutions



IVN

Automobile manufacturers today design decentralized, distributed systems, connected through industry interface standards. ON Semiconductor offers an innovative in-vehicle networking portfolio, including LIN, CAN, CANFD, and FlexRay™ transceivers - AEC qualified. The company also offers System Basis Chips that integrate transceivers with other circuits, including voltage regulators, drivers, and supervisory functions.

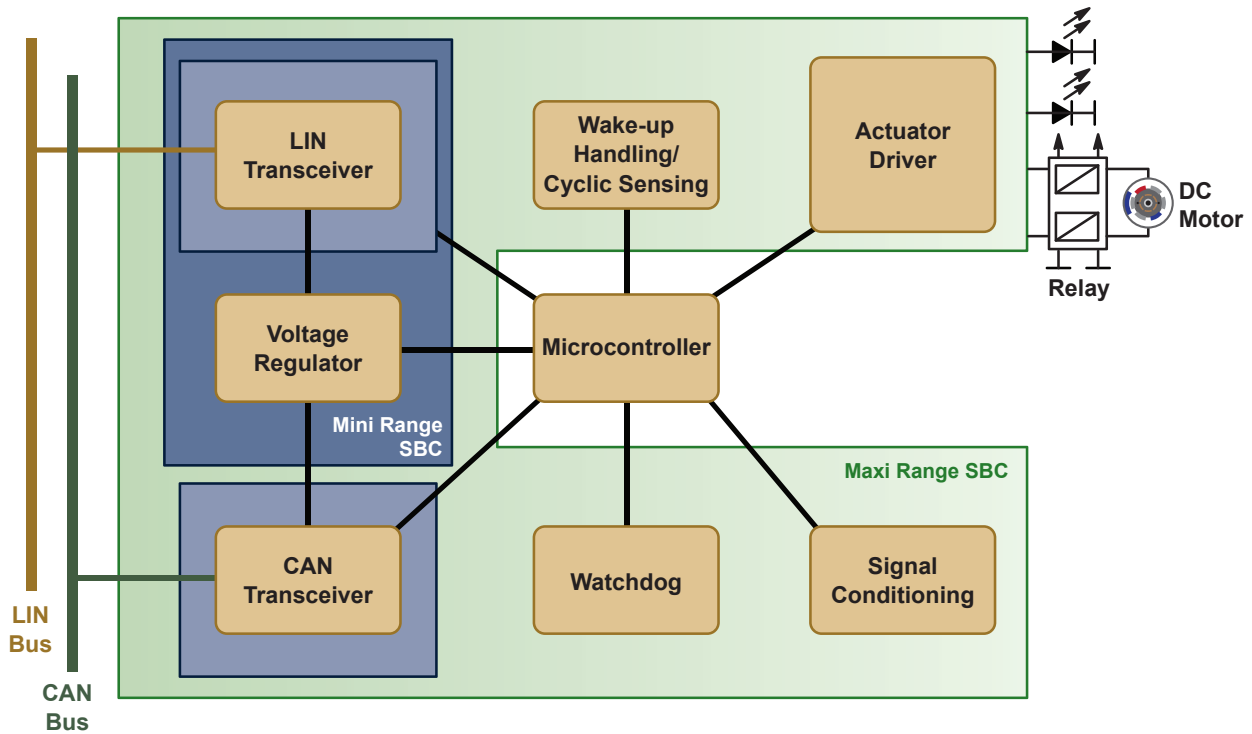

Typical System Partitioning with LIN and CAN Bus Connections

System Basis Chips

Integration of key system components, like LIN, CAN, and voltage regulators, within ECUs delivers:

- Improved system reliability
- Reduced power consumption
- Use of less board space
- Cost-optimized solutions

ON Semiconductor's IP, combined with years of experience designing integrated custom circuits, has led to successful development of a System Basis Chip portfolio.

NCV742x Features

- Based on NCV7321
- Ideal solution for low BOM slave nodes
- 3.3 V and 5 V versions
- NCV7420 includes 50 mA voltage regulator
- NCV7425 includes 150 mA voltage regulator

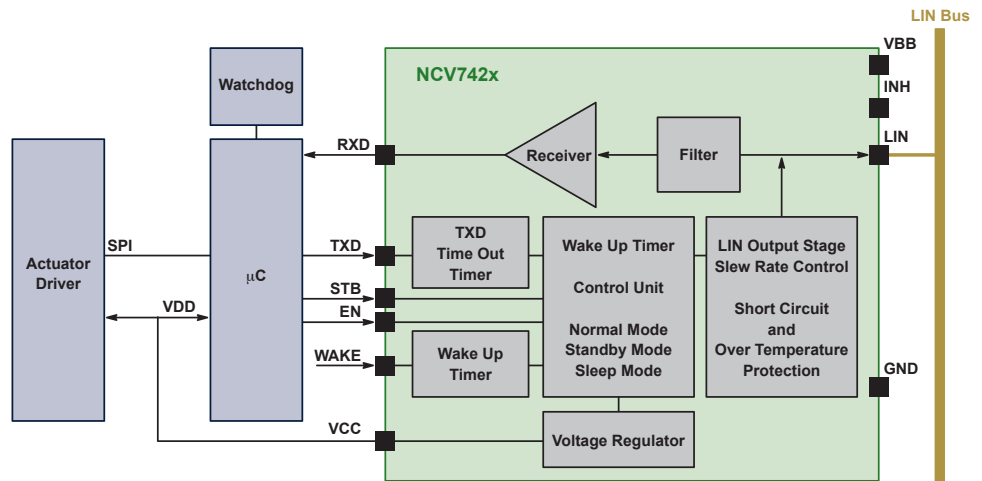

NCV742x LIN-SBC: LIN +LDO (5 or 3.3 V) up to 150 mA

System Basis Chips

Device	Description	Data Transmission Standard	I _Q Max (mA)	Number of Drivers	Number of Transceivers	V _{CC} Min (mA)	V _{CC} Max (mA)	Package(s)
NCV7420	System Basis Chip with LIN and Voltage Regulator (WAKE, INH)	LIN	50	0	1	5	26	SOIC-14
NCV7425	System Basis Chip with LIN and Voltage Regulator (WAKE, INH, RSTN)	LIN	150	0	1	5	28	SOIC-16W EP
NCV7428	LIN (low slope, normal slope) Transceiver with Voltage Regulator (70 mA, 3.3 or 5.0 V)	LIN	70	0	1	3.234, 4.9	3.366, 5.1	SOIC-8, DFN-8
NCV7429	System Basis Chip with LIN, LS and HS Switches	LIN	150	5	1	4.9	5.1	TSSOP-20 EP
NCV7430	System Basis Chip with LIN and RGB LED Driver	LIN	100	3	1	5.5	43	SOIC-14
NCV7462	System Basis Chip with LIN, CAN, 2 Voltage Regulators, and HS/LS Drivers	LIN; CAN	250	7	2	5	28	SSOP-36 EP
NCV7471	System Basis Chip with Dual LIN, CAN, Voltage Regulator, and Buck-Boost DC-DC	LIN; CAN	500	0	3	2.5	28	SSOP-36 EP
AMIS-42700/70	Dual High Speed CAN Transceiver	CAN	NA	0	2	NA	NA	SOIC-20
NCV7440	System Basis Chip with CAN and LDO	CAN	NA	0	1	NA	NA	DIE
NCV7441	Dual High Speed, Low Power CAN Transceiver	CAN	NA	0	2	NA	NA	SOIC-14
NCV7446	Two channel High Speed, Low Power CAN, CAN FD Transceiver	CAN/CANFD	NA	0	2	NA	NA	DFN-14

Standalone LIN Transceivers

The LIN bus communicates low rate (up to 20 kBaud) data from control devices - such as door locks, mirrors, car seats, and sunroofs - for non-time-critical functions. The LIN bus protocol uses only a single wire in each node, minimizing wiring costs. Each node includes a slave MCU state-machine that recognizes and translates the instructions specific to that function. ON Semiconductor offers products for both US (SAE J2602-2) and European (LIN Physical Layer Specification Rev. 2.x) standards.

NCV7321 Features

- Compliant to OEM requirements
- Outstanding EMC performance
- System ESD levels >12 kV
- Combines high voltage analog and digital functionality
- Transmission rate 1-20 kBaud

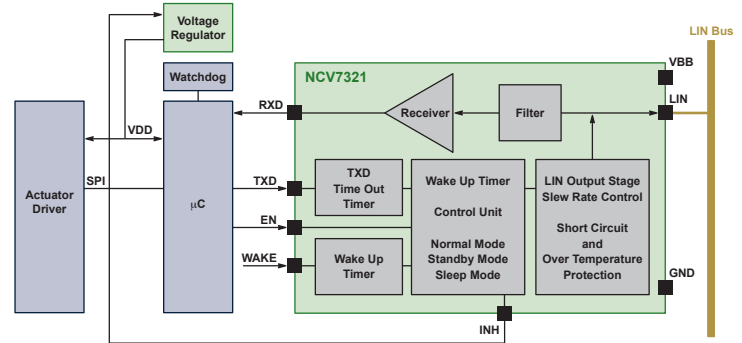

Standalone LIN Transceiver NCV7321

LIN Transceivers

Device	Description	Bus Speed (Baud)	ISO 9141	LIN 2.0/2.1/2.2	J2602	Sleep Mode Current (µA)	ESD Protection IEC 61000-4-2 (LIN pin)	Package(s)
AMIS-30600	LIN Transceiver	20 k	✓	✓	✓	55	6 kV	SOIC-8
NCV7321	LIN Transceiver	20 k	✓	✓	✓	10	>12 kV	SOIC-8
NCV7424	Quad LIN Transceiver	20 k	✓	✓	✓	30	>12 kV	TSSOP-16
NCV7329	LIN Transceiver	20 k	✓	✓	✓	10	>12 kV	SOIC-8
NCV7420	LIN Transceiver with Voltage Regulator (50 mA, 3.3 or 5.0 V)	20 k	✓	✓	✓	20	>12 kV	SOIC-14
NCV7422*	Dual LIN Transceiver	20 k	✓	✓	✓	20	>12 kV	DFN-14
NCV7425	LIN Transceiver with Voltage Regulator (150 mA, 3.3 or 5.0 V)	20 k	✓	✓	✓	20	>12 kV	SOIC-16W EP
NCV7428	LIN (low slope, normal slope) Transceiver with Voltage Regulator (70 mA, 3.3 or 5.0 V)	20 k	✓	✓	✓	25	>12 kV	SOIC-8
NCV7429	System Basis Chip with LIN, LS and HS Switches	20k	✓	✓	✓	30	>6 kV	TSSOP-20 EP

* Pending 4Q18.

FlexRay™ Transceivers

Features

- Compliant to FlexRay v3.0.1 physical layer
- Excellent EMC and ESD performance

FlexRay™ Transceivers

Product	Description	Bus Speed (Baud)	FlexRay Standard	Host Interface	ESD Protection IEC61000-4-2 (CAN pins)	Package(s)
NCV7381A	Clamp-30 FlexRay Transceiver	10 M	v3.0.1.	ERRN pin	>10 kV	SSOP-16
NCV7383	Clamp-15 FlexRay Transceiver	10 M	v3.0.1.	SPI	> 10 kV	TSSOP-14



Standalone CAN Transceivers

The latest generation CAN transceivers exhibit industry-leading performance on electromagnetic capabilities (ESD and EMI). These devices are designed in ON Semiconductor's proven, innovative I3T technology, that delivers highly robust, high quality components with failure rates measured in parts-per-billion.



Features

- Portfolio includes transceivers specifically designed for:
 - Low Speed Fault Tolerant
 - High Speed
 - Low Power
 - Single Wire
 - Flexible Data Rate
- Conformance tested by external test house (ISO11898)
- System ESD protection according to IEC 61000-4-2
- Highly robust against EM fields (low Electro Magnetic Susceptibility - EMS)

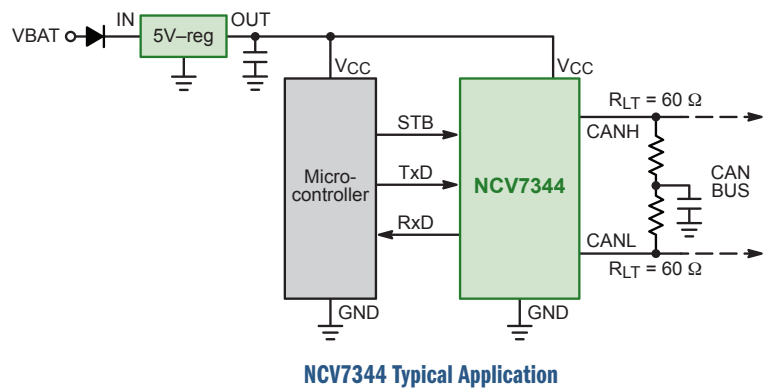

CAN Transceivers

Device	Description	Standard	Sleepmode Current Max (µA)	Bus Speed Max	ESD Protection IEC 61000-4-2 (CAN pins)	Package(s)
NCV7344	High Speed Low Power CAN, CANFD Transceiver	ISO11898-2:2016	15	5 Mbps	>8 kV	SOIC-8, DFN-8
NCV7357***	High Speed Low Power CAN, CANFD Transceiver	ISO11898-2:2016	15	5 Mbps	>8 kV	SOIC-8, DFN-8
NCV7446	Two channel High Speed, Low Power CAN, CAN FD Transceiver	ISO11898-2:2016	30	5 Mbps	8 kV	DFN-14
NCV7351F	High Speed CAN, CANFD Transceiver	ISO11898-2:2016	N/A*	2 Mbps	>12 kV	SOIC-8
NCV7349	High Speed, Low Power CAN Transceiver**	ISO11898-5	15	1 Mbps	>12 kV	SOIC-8
NCV7342	High Speed, Low Power CAN Transceiver	ISO11898-5	15	1 Mbps	>12 kV	SOIC-8, DFN-8
NCV7340	High Speed, Low Power CAN Transceiver	ISO11898-5	15	1 Mbps	>12 kV	SOIC-8
AMIS-42665	High Speed, Low Power CAN Transceiver	ISO11898-5	15	1 Mbps	4 kV (HBM)	SOIC-8
NCV7441	Dual High Speed, Low Power CAN Transceiver	ISO11898-5	30	1 Mbps	8 kV	SOIC-14
NCV7341	High Speed, Low Power CAN Transceiver	ISO11898-5	35	1 Mbps	8 kV	SOIC-14
AMIS-42700	Dual High Speed CAN Transceiver	ISO11898-2	N/A*	1 Mbps	4 kV	SOIC-20
NCV7351	High Speed CAN Transceiver	ISO11898-2	N/A*	1 Mbps	>12 kV	SOIC-8
AMIS-30660	High Speed CAN Transceiver	ISO11898-2	N/A*	1 Mbps	4 kV	SOIC-8
AMIS-30663	High Speed CAN Transceiver	ISO11898-2	N/A*	1 Mbps	4 kV	SOIC-8
AMIS-41682	Low Speed Fault Tolerant CAN Transceiver	ISO11898-3	60	250 kbps	6 kV (HBM)	SOIC-14
AMIS-41683	Low Speed Fault Tolerant CAN Transceiver	ISO11898-3	60	250 kbps	6 kV (HBM)	SOIC-14
NCV7356	Single Wire CAN Transceiver	J2411	60	40 kbps	4 kV (HBM)	SOIC-14

* Sleepmode not featured/implemented. **SW-CAN - Not defined in ISO. *** Pending 4Q18.

Door Electronics Systems

Door electronics are prevalent in modern vehicles, with most automobiles containing electronic window lifts and central locks. Additional safety features, like pinch protection and child-proof locks, increase the electronic content in door modules. Additional available features include side mirror positioning, folding, and defrosting; and for high-end models, electrochromic mirror control, that darkens the mirror depending on the brightness of the irradiated beam of oncoming traffic. Some lamp applications, like flashers in the mirror or some LEDs for interior lights, are also being adopted.

There are different door electronic topologies available:

- Centralized door electronics
- De-centralized door electronics
- Mixed door electronics

Centralized Door Electronics System

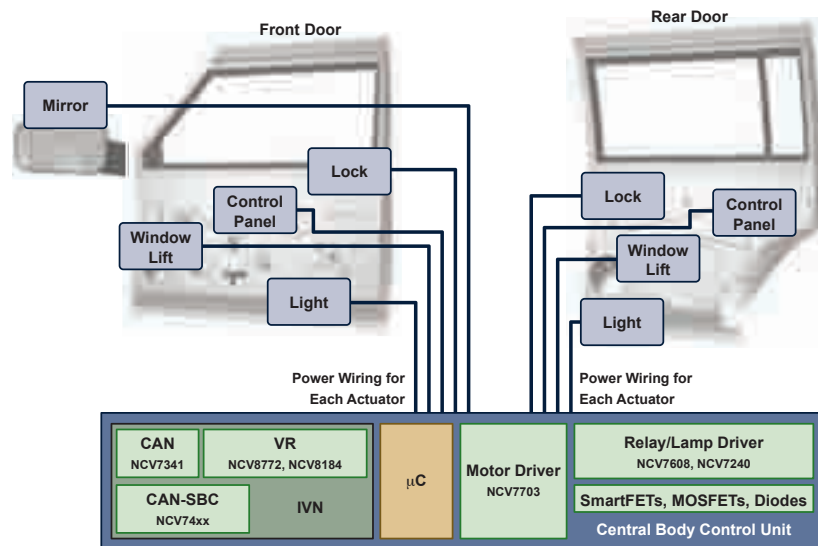

The most common topology is centralized electronics, where the electronics system is implemented in the Body Control Unit (BCU). ON Semiconductor offers:

- In-Vehicle-Networking - CAN transceivers, LIN transceivers, system-basis-chips
- Voltage regulators
- Load drivers for motors, lamps, and relay controls
- Logic functions
- Discrete components - diodes, transistors, protection devices

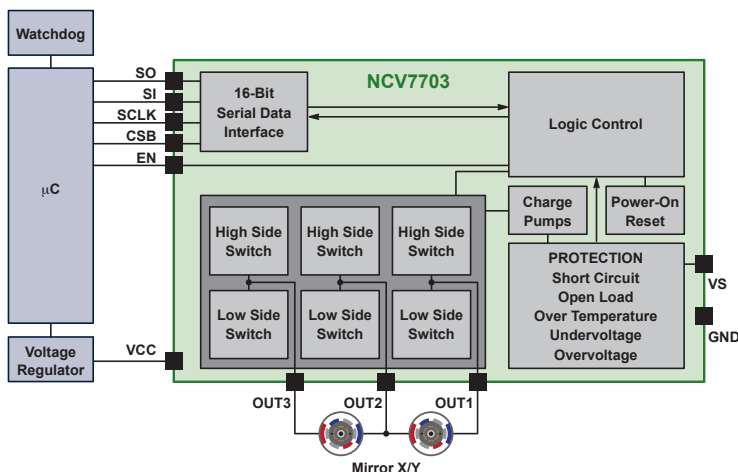

For mirror positioning, two motors adjust the glass along x and y axes. The NCV7703 features three integrated half-bridge drivers. The output stages are controlled by a 16-bit SPI interface. Complete diagnostic information is provided to the microcontroller through the SPI.

Door Electronics Systems

De-Centralized Door Electronics System

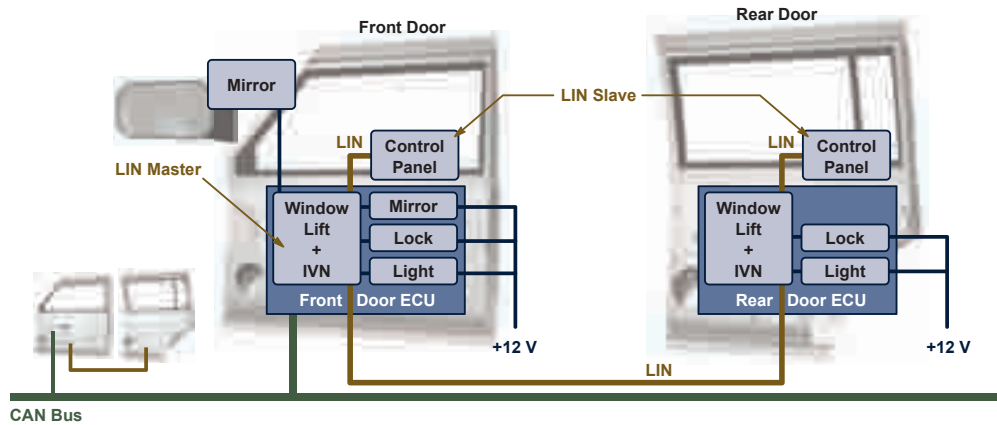

As the electronics content becomes more complex, the large amount of wires drives designs toward a de-centralized topology. The de-centralized door modules communicate over a CAN or LIN bus system.

Benefits of de-centralized door module topologies:

- Reduced use of wiring harness
- Reduced weight and power consumption positively impact fuel consumption
- Enables modular architectures through use of sub-modules

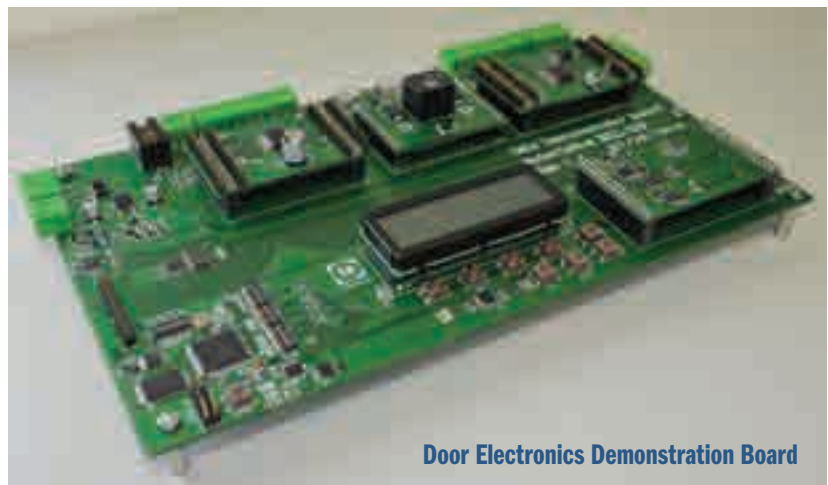

Solution for De-Centralized Front Door Electronics Systems

ON Semiconductor supplies ASSPs for door module electronics, including CAN- and LIN-enabled SBCs designed specifically for door modules. Smart Power BCD Technology enables the integration of powerful driver stages, that may be used for door locks, mirror folding and heating, and lamp drivers. The integration of complex state machines and PWM control units creates components that are flexible enough to drive different types of lamps and motors. Standard products like multiplex devices, amplifiers, MOSFETs, bus and supply protection components, allows ON Semiconductor the opportunity to support complete customer designs.

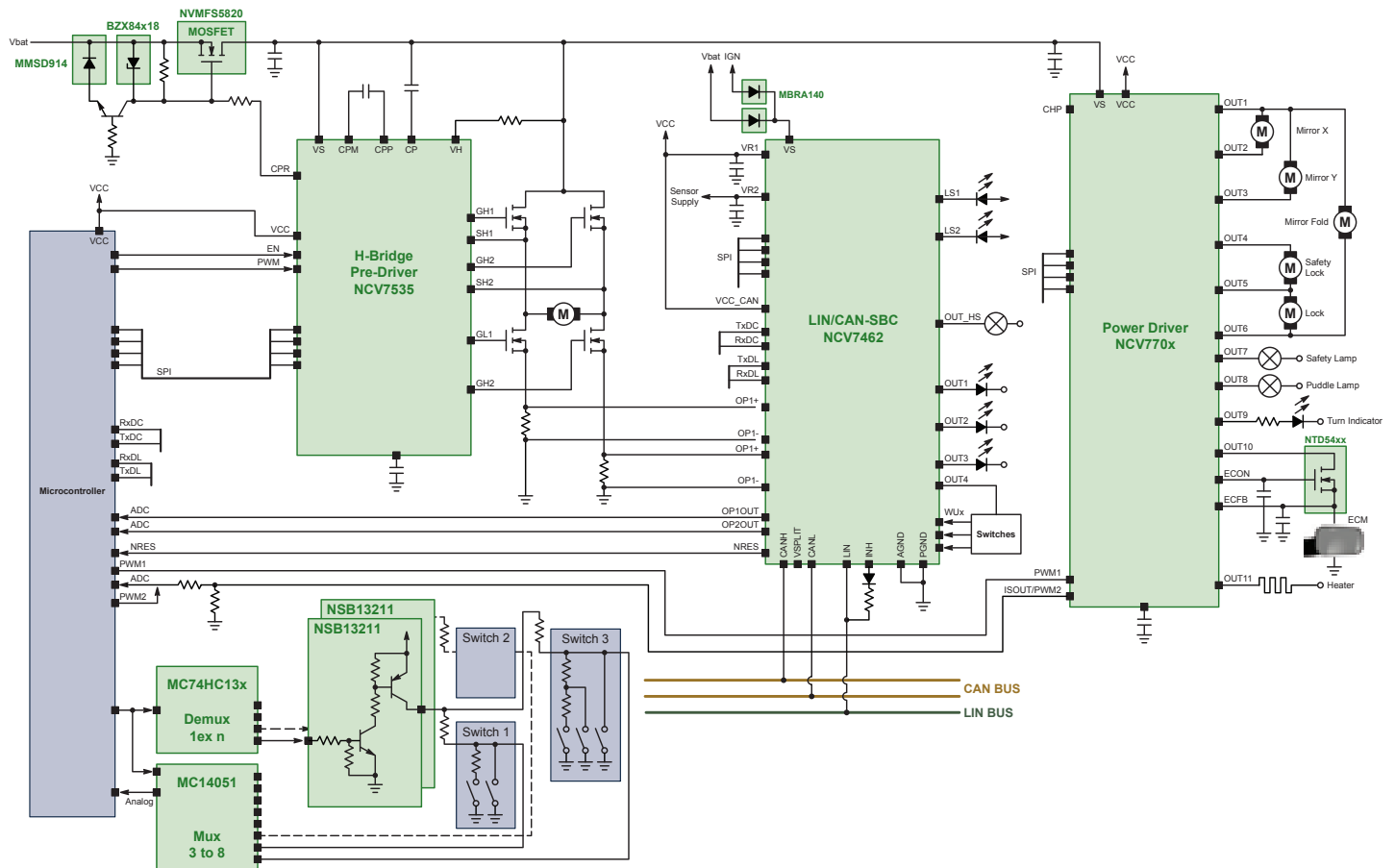

BODY

Control, Communication, and Power for Body HVAC

The HVAC system includes several subsystems

Vehicle heating & ventilation systems

To improve passenger comfort and safety, fresh air is drawn from outside ducts and directed to the passenger compartment. Incoming air can be heated by passing over a small heating core connected to the engine's cooling system.

Air conditioning refrigerant

The refrigerant removes heat from the vehicle interior and transfers it to the outside air in a continuous cycle of vaporization and condensation. Reducing the temperature of the air also reduces its humidity. Cold air will not hold as much water vapor as warm air.

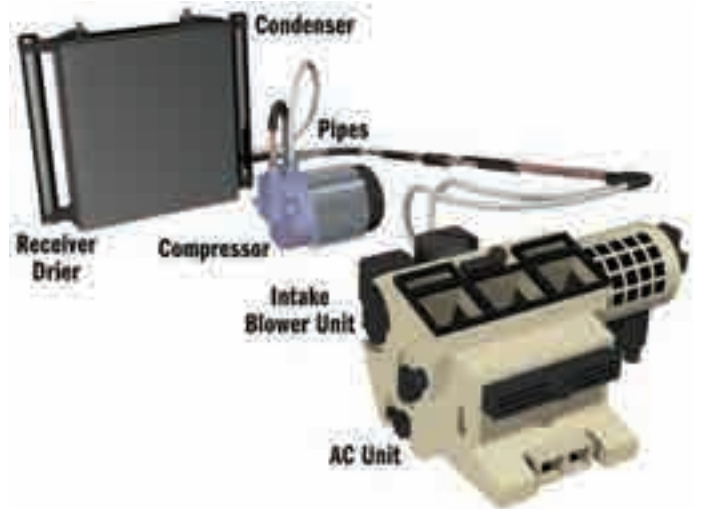

Interior Air Conditioning Unit

Control head

ECU (Electronic Control Unit) with user interface.

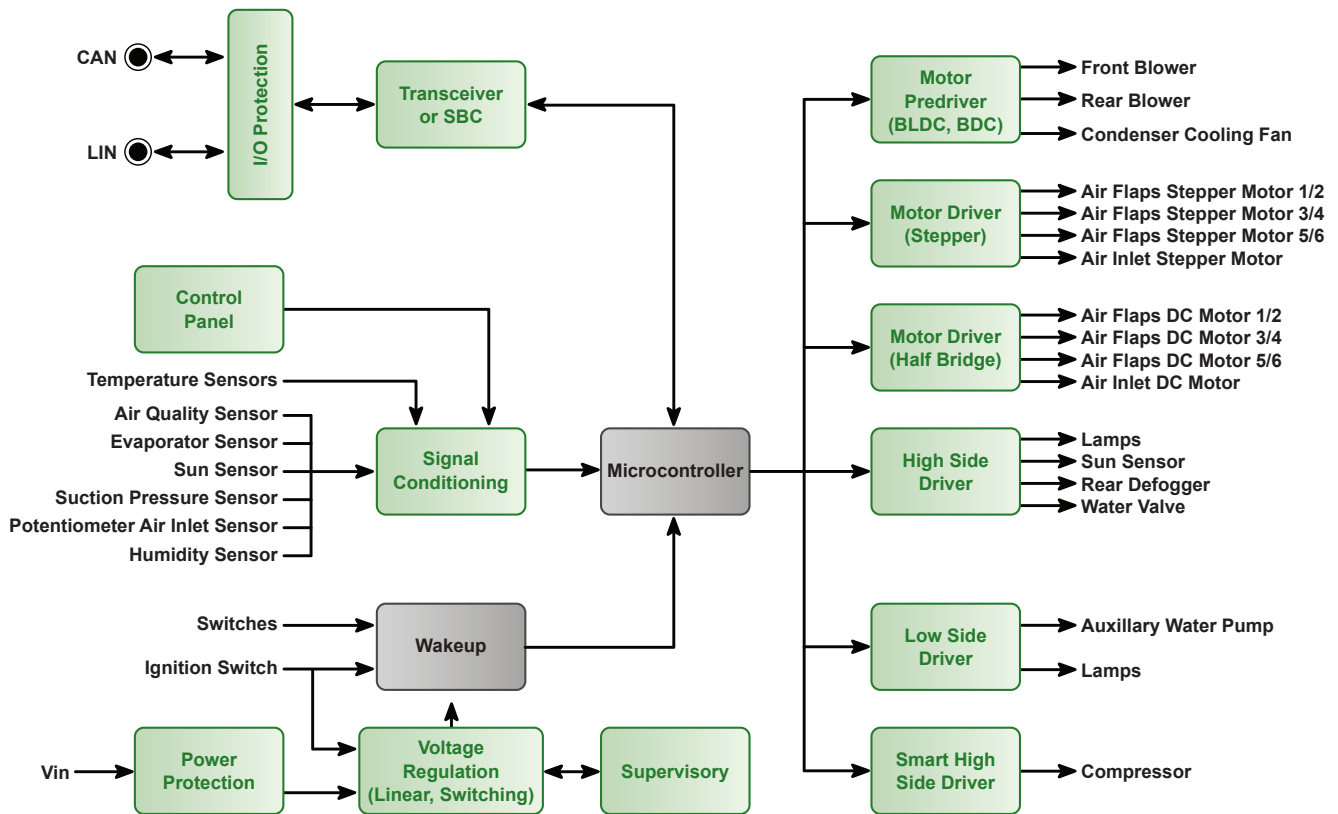

DC Motor Drivers for Body HVAC

The most popular flap actuators are simple DC motors with position signal feedback to the microcontroller. To control a DC motor in forward and reverse direction, two high-side and two low-side power stages are necessary, in full-bridge configuration. Typically, these drivers integrate required features such as overvoltage, overload, and over temperature protection. In addition, the SPI interface provides diagnostics to the microcontroller.

Integrated pulse count technology combined with an extra signal conditioning block replaces the discrete position potentiometer. In pulse count applications, the circuit detects the DC motor commutation pulses and creates a pulse for every detected commutation pulse. These pulses are generally fed back to a microcontroller for position sensing and control. ON Semiconductor has custom ASICs for these types of circuits, in production today.

Dual Hex High/Low-Side Driver

The NCV7708 is a flexible, single sided high/low-side driver. The six high and low-side channels are specifically designed for motor control configurations, like half or full bridges. NCV7708 will control five DC motors via a 16-bit SPI interface. The device can also control relays or LEDs.

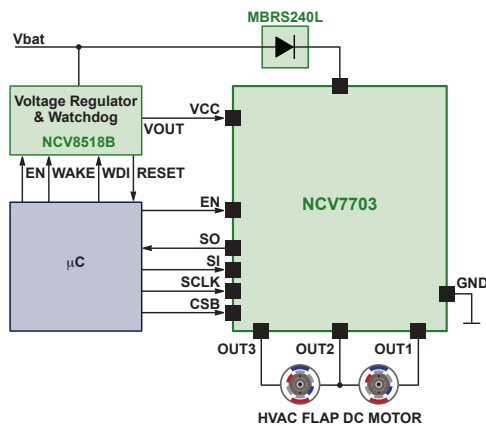
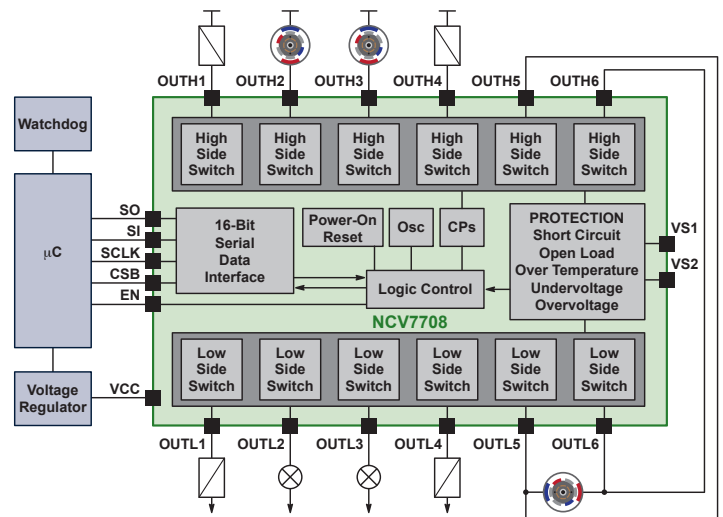

Half-Bridge Drivers

NCV7703 triple half-bridge driver controls two DC Motors. The power stages are internally connected as half-bridges, which allows a pin-count reduction to the SOIC-14 package. NCV7718 hex half-bridge driver controls up to 5 DC motors, and is offered in the SSOP-24 package. NCV7719 and NCV7720 increases the number of outputs to 8-channel and 10-channel, respectively.

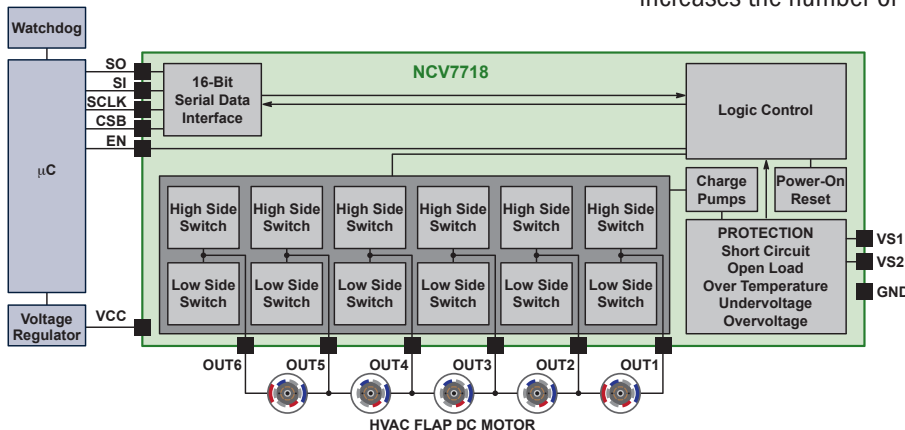

Configurable Motor, Relay, and LED Driver for Body HVAC

The NCV7608 drives different types of motors and various loads, such as bulbs, LEDs, and relays. The eight integrated output drivers are configurable in any combination of high-side, low-side, or half-bridge. This enables connection to DC, unipolar, or bipolar stepper motors. In addition, four channels include external PWM control capability. NCV7608 includes a special diagnostic current disable bit to prevent LED-glowing, as well as standard diagnostic features.

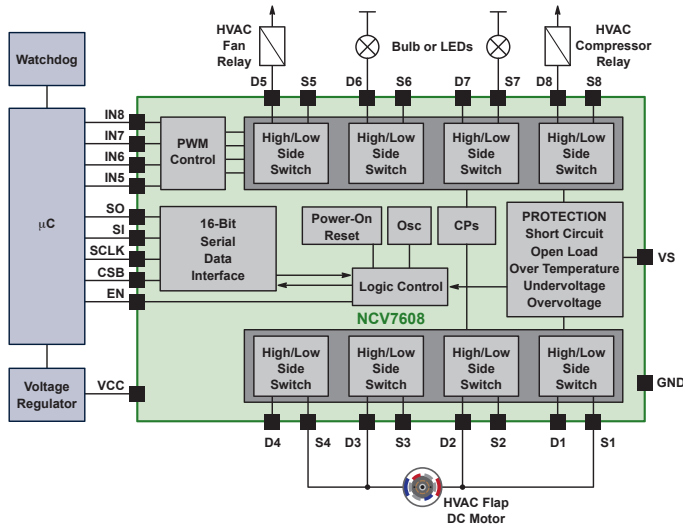

Highest Flexibility with NCV7608

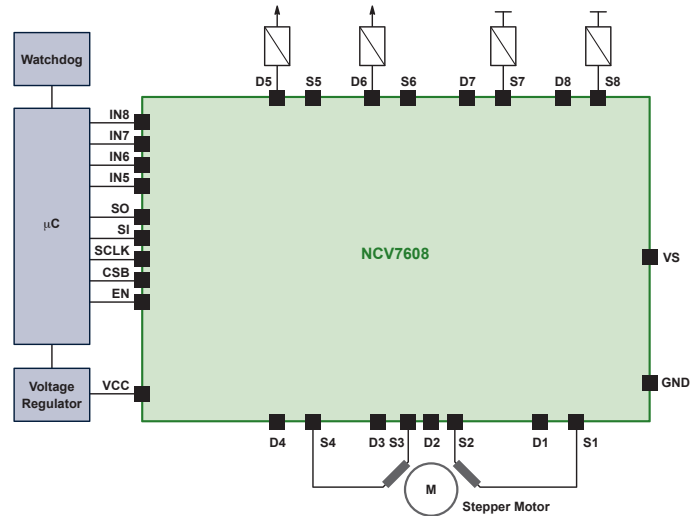

NCV7608 Supports Unipolar and Bipolar Stepper Motor Control

The NCV7240/54 eight channel low-side drivers and NCV7751 twelve channel low-side driver provide drive capability up to 600 mA per channel. Output control via SPI port offers convenient reporting of faults. Additionally, parallel control of the outputs is addressable (in pairs) via the INx pins. A dedicated limp-home mode pin (LHI) enables OUT1-OUT4 while disabling OUT5-OUT8. The devices are able to drive loads like LEDs, relays, or unipolar stepper motors.

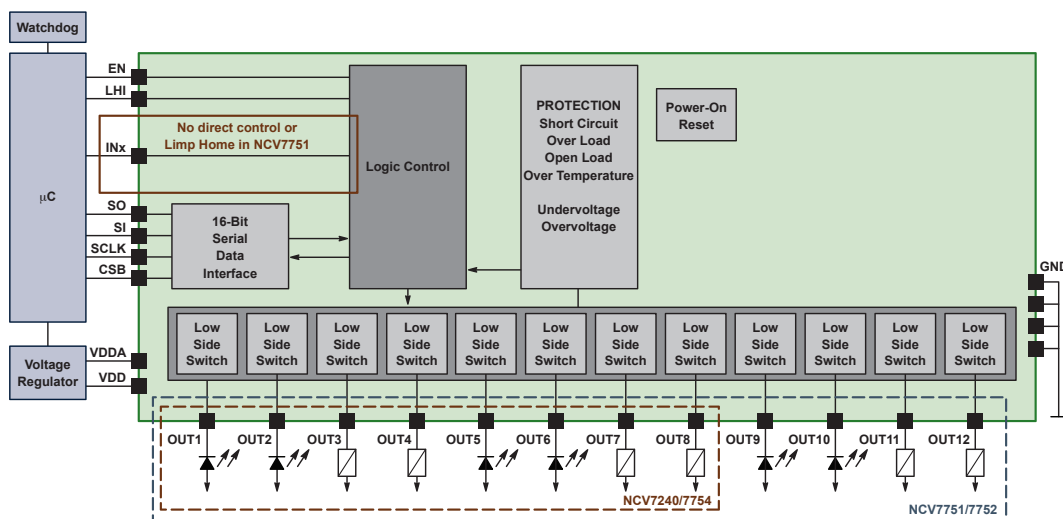

Bipolar Stepper Motor Drivers for HVAC

In climate control systems unipolar and bipolar stepper actuators are used. For unipolar solutions the control electronic is more simple compared to bipolar ones. Instead of four low-side switches for unipolar motors, the bipolar requires two full-bridges.

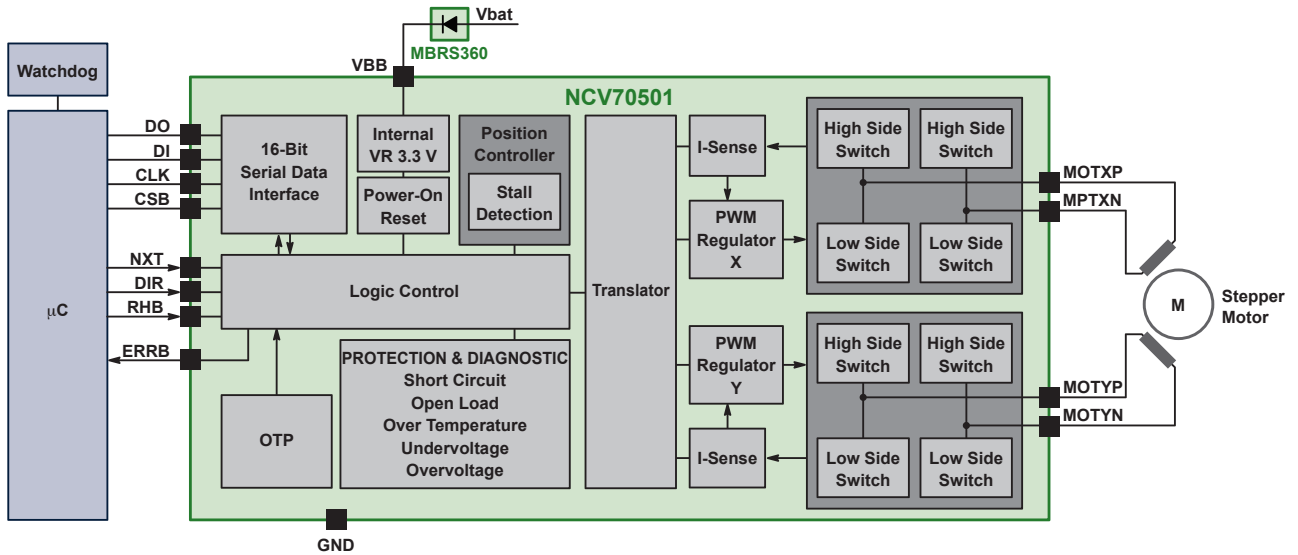

Air-inlet flaps require low acoustic noise because the actuator operates in a continuous manner. Low acoustic noise can be achieved by using stepper motors, such as the NCV70501 micro-stepping stepper motor driver for bipolar stepper motors. NCV70501 controls the current through the windings of the bipolar stepper motor, contains a current-translation table and takes the next micro-step depending on the clock signal on the “NXT” input pin and the status of the “DIR” (=direction) register or input pin. An external microcontroller can work in interrupt mode, so there is no need to monitor the status registers continuously.

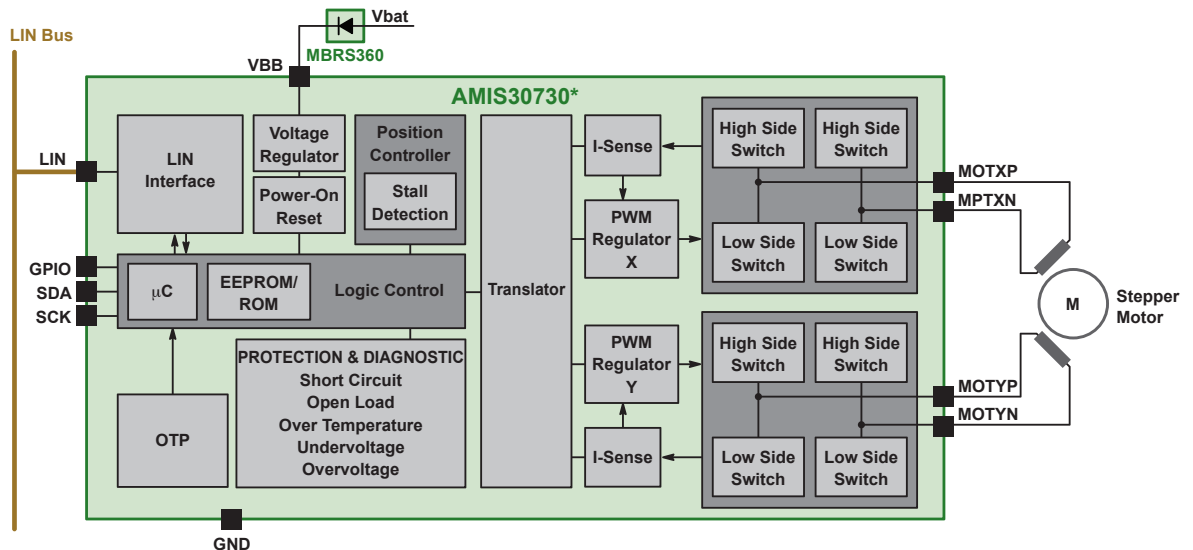

* Customer specific embedded software

AMIS-30730 is a single-chip platform for intelligent stepper motor drivers with embedded microcontroller and LIN interfaces. The device may be customized with embedded software for dedicated mechatronic solutions connected remotely with a LIN master.

BODY

Air Flap Actuator Driver Topologies for HVAC

Climate control systems may operate with different system topologies - driven by the different regional and OEM requirements.

Actuator Types

- Direct controlled actuators
 - DC motors (with and without position feedback)
 - Unipolar stepper motors
 - Bipolar stepper motors
- Bus connected mechatronic actuators
 - LIN bipolar stepper motors

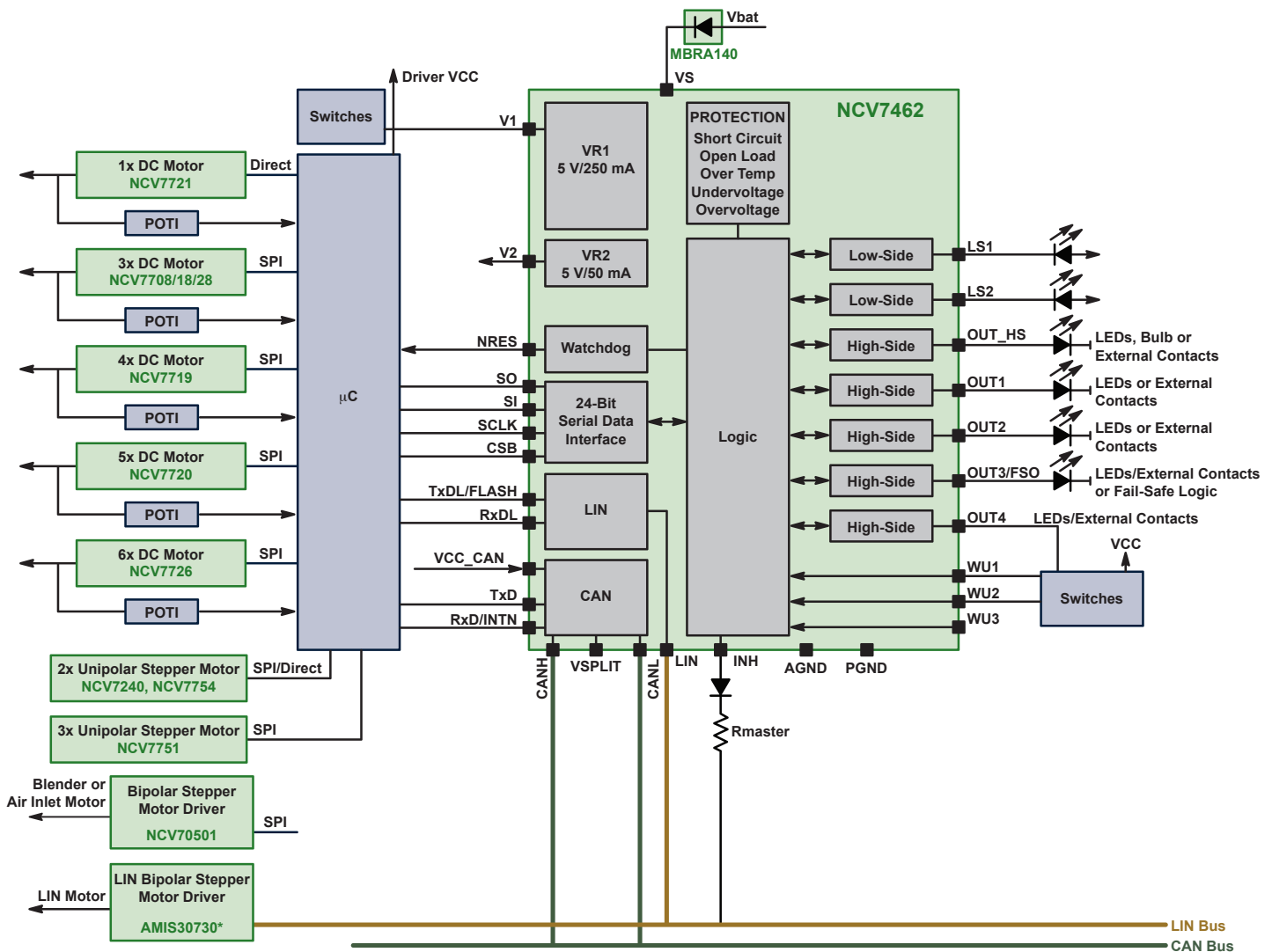

* Customer specific embedded software

BODY

BLDC Motor Driver

BLDC motors enable higher efficiency and torque, and are therefore increasingly being adapted into automotive applications. Designs can be optimized through the use of specialized pre-drivers, such as the LV8907UW three-phase BLDC pre-driver.

LV8907UW Features

- Integrated sensor-less control
- Integrated gate drivers for external power MOSFETs
- Integrated LIN transceiver and LDO
- Integrated protection (Under-voltage, Over-temperature, Over-current, Locked Rotor, PWM Fault)
- Operation up to 175°C junction temperature
- OTP for configuration and standalone operation
- SPI for real-time control
- VIN of 5.5 - 20 V
- SQFP-48 package

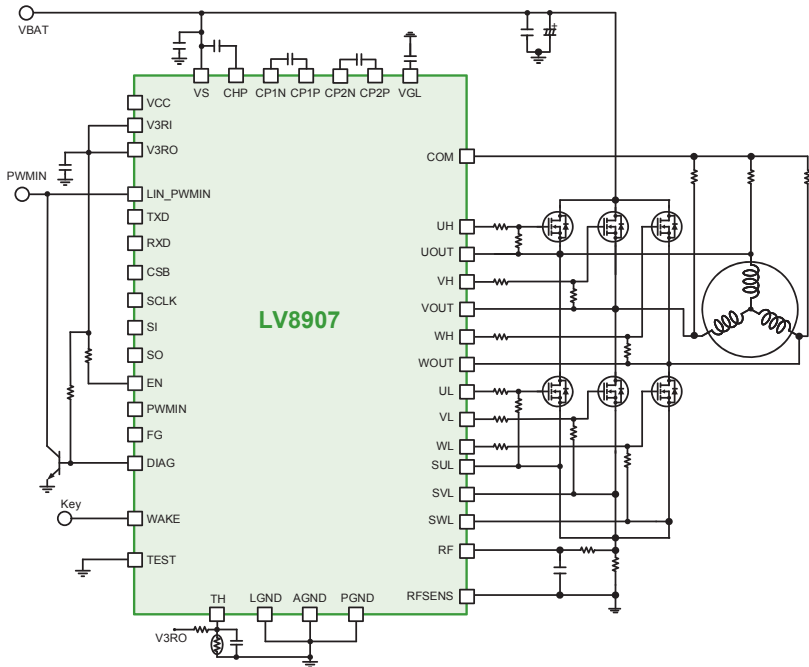

Standalone Configuration Application Diagram

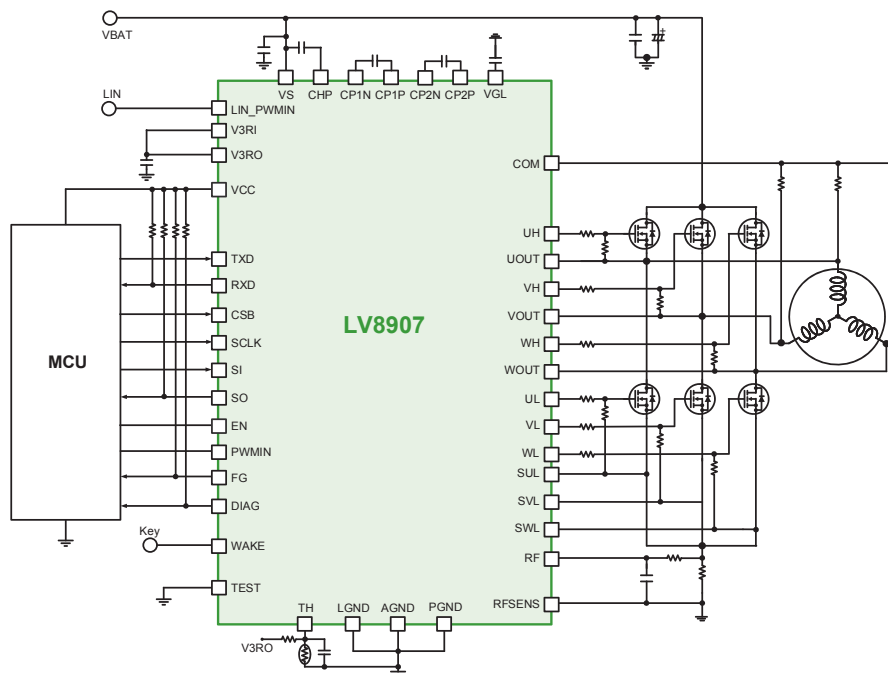

LIN-Based Control Configuration Application Diagram

LIN-Based Low-Side Relay Drivers for Automotive Power Distribution Relays

NCV7748 Features

- Reduce harness complexity for Power Distribution Boxes
- Scalable between 4 or 8 channels
- Ability to control up to 32 relays with Virtual Node concept
- Diagnostics for abnormal load conditions
- Integrated clamps for inductive loads
- Designed for both PCB mounted or socketed relays
- Reduce PCB area and weight

BODY

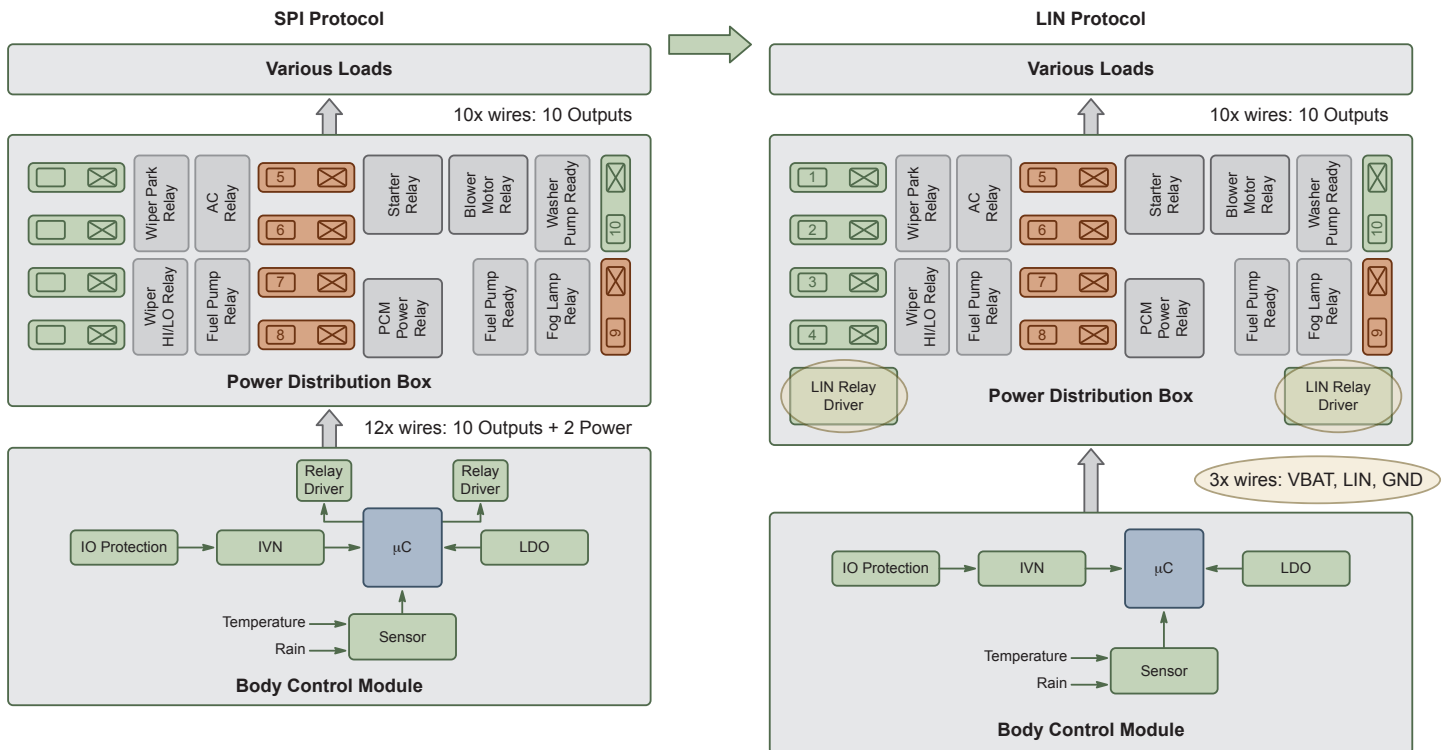

Saves nine interconnect wires between the Body Control Module (BCM) and the Power Distribution Box (PDB)

Engine Management Systems

Approximately 80% of engines in the world are gasoline engines. Gasoline engines are starting to incorporate direct injection and turbo charging, to improve the efficiency of the simple and cost-effective engine. Gasoline engines will continue to be the predominant power source world wide; however, diesel engines have achieved ~40% penetration in Europe and have additional potential in North America.

Automotive electronics contributes to the drive for efficiency through control, sensing and actuation of the engine. Critical components, such as injectors and valves, are carefully controlled to reach the maximum efficiency. To improve control, pressure in the combustion chamber is measured and processed in real time, in order to reduce fuel consumption of the gasoline engine by 30%.

ON Semiconductor has developed numerous custom solutions and standard products for gasoline, bi/flexfuel, and diesel engines. The company's expertise covers the full spectrum of applications, ranging from air and fuel supply over ignition control, to exhaust after-treatment subsystems.

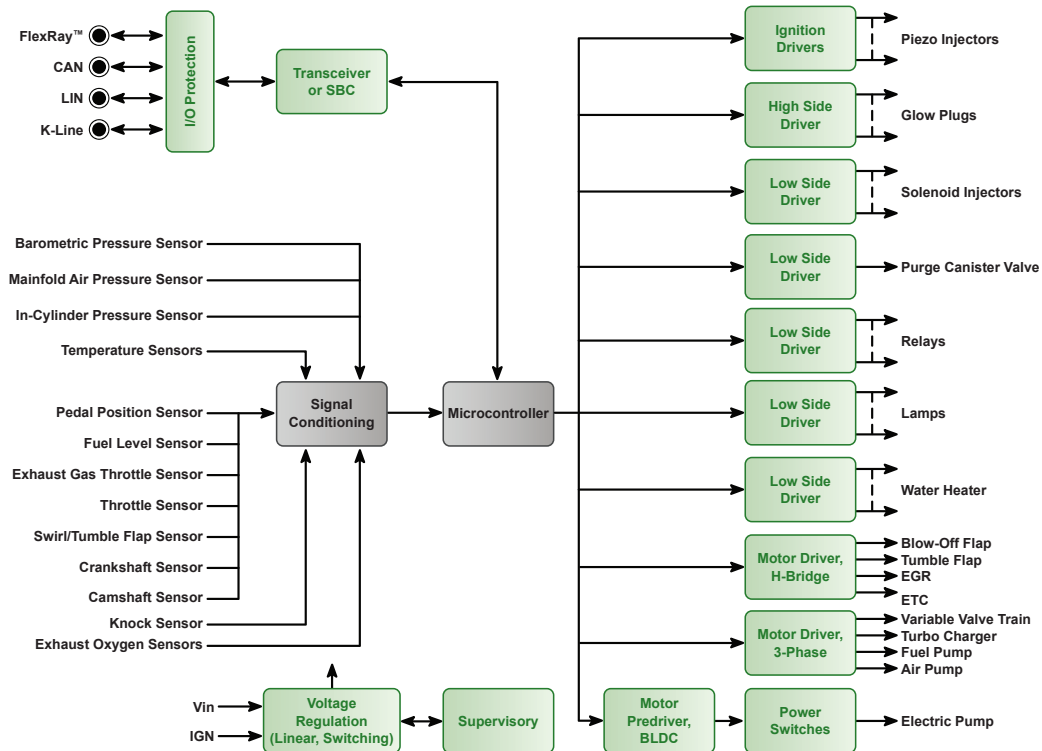

Diesel Engine Management System

Product Portfolio

- Inductive angular sensor interfaces
- Pressure sensor interfaces
- Knock- and wheel-speed detection circuits
- Oil-, urea- and air-flow interfaces
- In-vehicle networking components
- Actuator drivers and pre-drivers for throttle and flaps, solenoid- and piezo-fuel injection systems, spark ignition, fans, pumps, and hydraulic controls



Power Management Rails for Powertrain

Increasing demand for lower emissions, higher fuel economy, higher efficiency engines, and higher performance vehicles drive the need for precise control of ignition, fuel systems, and exhaust control. In order to efficiently perform all these functions, the latest generation of engine controllers need high-end 32-bit multi-core processors. These high-end microprocessors require efficient and reliable power management subsystems.

The power management subsystem must be able to handle various battery transients, such as load dump, double battery, reverse battery, and other inductive and capacity coupled transients. The subsystem typically provides regulated 5 V, 3.3 V, 1.0-1.5 V, and other tracking outputs, to power microcontrollers, sensors, memories, and other peripheral devices in the ECU.

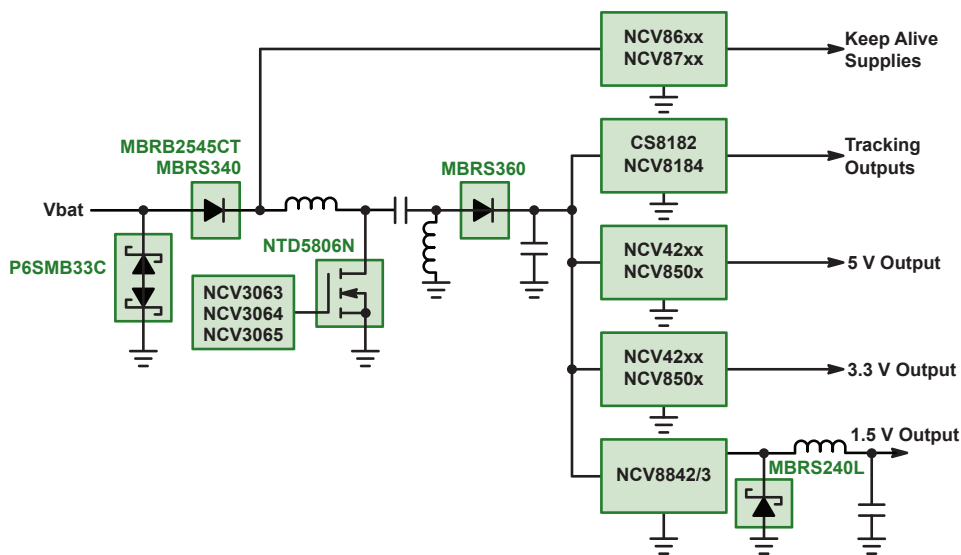

ON Semiconductor offers a wide selection of highly efficient power supply solutions that can handle harsh powertrain battery transients. The portfolio includes multi-topology controllers, such as NCV8871 and NCV3063, to provide regulated voltage greater than 5 V with a battery operating voltage between 4 V to 18 V; as well as buck regulators and controllers, like NCV8851 and NCV8842, to supply the high current, low voltage microcontroller cores.

To support 'keep alive' 5 V and 3.3 V voltage rails in an ECU, ON Semiconductor offers a wide selection of low Iq and standard linear voltage regulators. In addition, fully protected tracking regulators – such as NCV4250-2C, NCV8184, CS8182, and CS8361 – that can power external sensors, complete the portfolio.

Along with the linear regulators and switch mode power supplies, ON Semiconductors also offers power MOSFETs for SEPIC and BUCK applications, as well as low Vf rectifiers and TVS diodes for reverse battery and load dump applications.

ASICs for Powertrain

Cylinder Pressure Sensing

Monitoring and measuring pressure is an integral part of engine management. Pressure sensors keep track of conditions within the manifold (MAP and TMAP), monitor diesel particle filters, and control the high pressures involved in both diesel and gasoline direct injection. In-cylinder pressure sensing (ICPS) enables even more accurate combustion control, to allow further reduction in NOx and CO2 emissions, for cleaner diesels and other advanced internal combustion engines of the future.

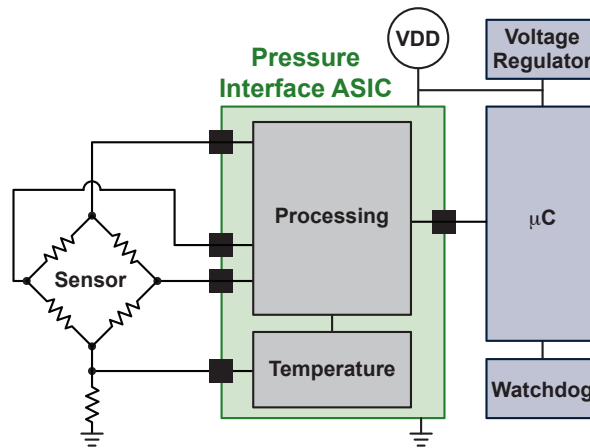

Micro-Hybrid

Micro-Hybrids are start-stop vehicles with additional features to reduce CO2 emissions: the internal combustion engine is switched-off while the vehicle is still moving; regenerative brake energy can be captured in a dedicated power-storage system; and electricity generation is avoided during acceleration. An efficient alternator or an Integrated Starter Generator (ISG) replaces the standard alternator while dedicated integrated circuits control the power net stability. Some of the 12 V high power loads (such as electric power steering and window defrosters) and some belt-driven ancillary loads (such as water pump, compressor, fan) can be replaced by electric drives from a 48 V battery. ON Semiconductor offers robust technologies, key intellectual property, and production proven solutions that address the harsh environments in these emerging applications.

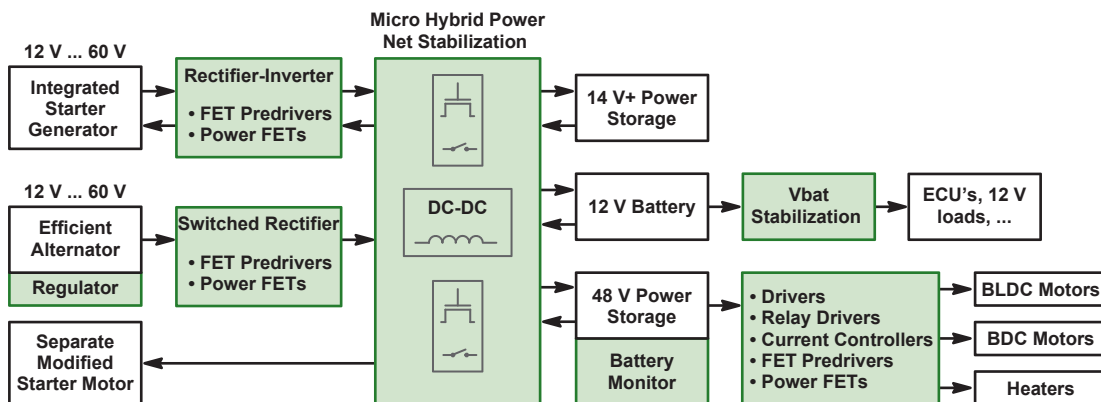

Flap Control

To reduce fuel consumption and meet the strict requirements for the different regulations in the automotive industry - e.g., Euro-4 (2005), Euro-5 (2009), and Euro-6 (2014) - modern engine management systems must optimize the engine's efficiency, and reduce emissions of soot, NO_x (Nitrogen Oxide), HC (Hydrocarbon), and CO (Carbon Monoxide). Therefore, the engine control unit needs to control the combustion process in an extremely precise manner. Flap control systems include several air and exhaust gas flaps:

- Electronic throttle
- Exhaust recirculation flap
- Tumble flap
- Blow-off flap

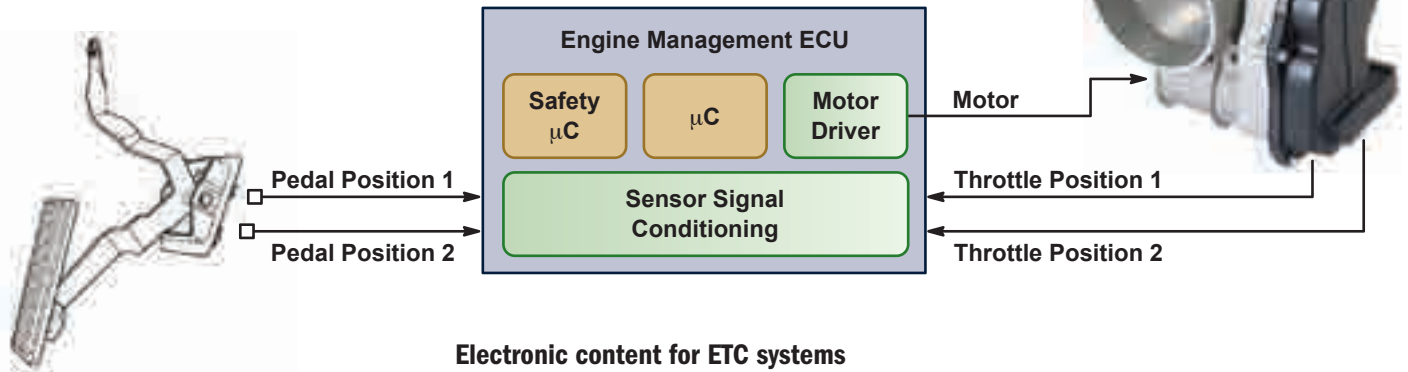

Electronic content for ETC systems

- Pedal position sensor (inductive or Hall effect)
- Throttle position sensor (potentiometer, inductive, or Hall effect)
- DC motor control

Injection Systems

Fuel injection systems carefully meter the amount and timing of fuel to each cylinder. Fully integrated multi-point (MPI) gasoline engine management systems remain by far the most popular solution. However, the gasoline direct injection (GDI) system has the strongest growth rate.

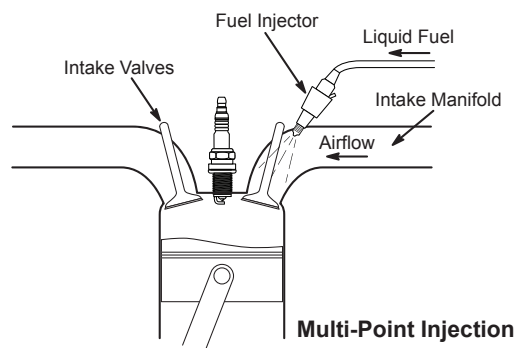

Multi-Point Injection

Multi-point Indirect Injection

Gasoline engines are typically equipped with indirect injection systems. They may be single point (SPI) where the fuel is injected in the throttle housing; or multi point (MPI) where each cylinder has its own injector in the inlet manifold.

Direct Injection

Many diesel engines feature direct injection (DI) technology. The injector nozzle is placed inside the combustion chamber itself. The gasoline direct injection engine (GDI) utilizes this system as

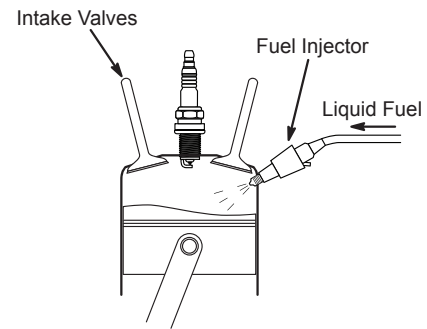

Direct Injection

well, since it gives a better volumetric efficiency as only air is drawn in through the induction system, increasing the amount of air induced and minimizing fuel losses. The injector also features several spray modes, so the fuel is better distributed and a powerful air-fuel mixture is created. The injector actuator is implemented as a solenoid or a piezo based solution. With piezo technology, fuel can be more precisely dosed when injected into an engine's combustion chamber, considerably reducing fuel consumption and exhaust emissions.



Solutions for Injection Systems

Multi-Point Indirect Injection

The FLEXMOS™ family from ON Semiconductor offers application specific scalability through the choice of external MOSFETs. These low-side pre-drivers are programmable six channel products for driving logic-level MOSFETs. The devices are controllable by a combination of serial SPI and parallel inputs. They feature programmable fault management modes and allow power-limiting PWM operation with programmable refresh time. Each channel independently monitors its external MOSFET's drain voltage for fault conditions. Shorted load fault detection thresholds are fully programmable. Fault information for each channel is encoded by fault type and is available through SPI communication.

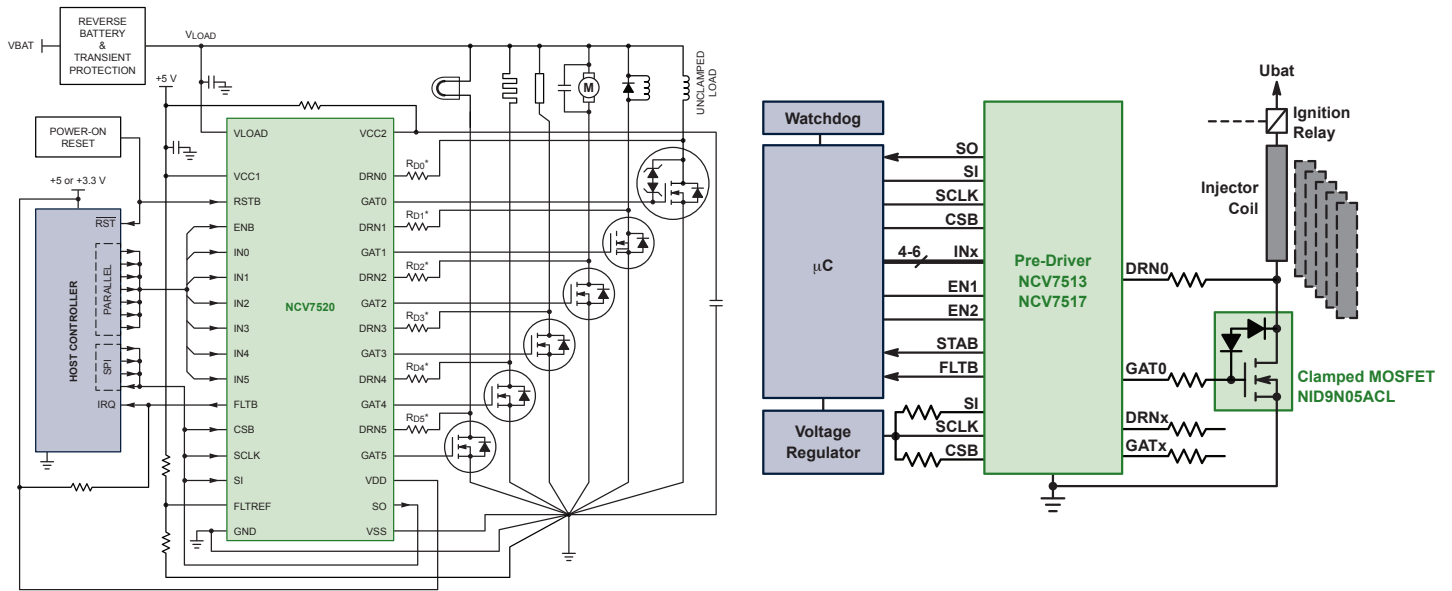

Direct Injection

Engine management systems - in particular, injection functions - are subject to extensive qualification cycles, due to the harsh operating conditions of wide temperature and voltage ranges, and switching of inductive and capacitive loads. ON Semiconductor has developed multiple drivers for injection systems, using proprietary design techniques, combined with high-voltage manufacturing processes.

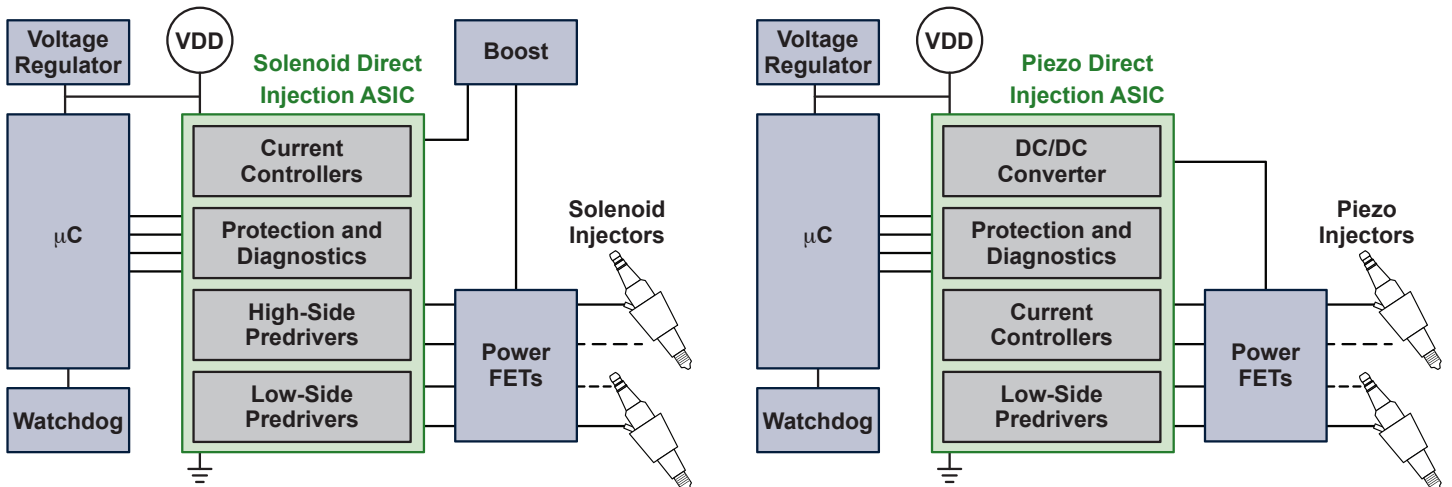

POWERTRAIN

Igniters for Ignition Systems

Provides the power electronic circuit to energize an ignition coil for creating a spark across the spark plug.

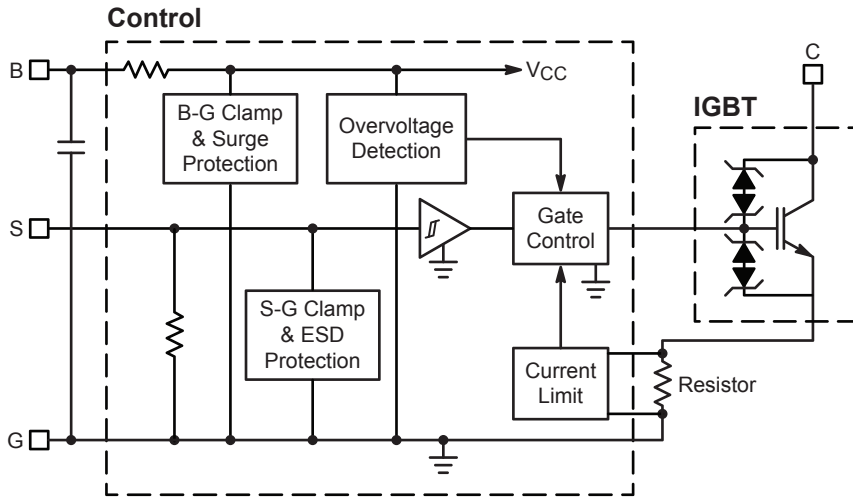

Features

- Overcurrent protection
- Overvoltage shutdown
- B input resistor & B-G clamp
- B-G capacitor (filter)
- Clamp voltages 350 - 600 V
- Output current 8 - 20 A

Igniter Module Requirements

- Compact - space constraint in coil head
- Highly robust and reliable - life time > 15 years, under hood

LA9931UVC Igniter Module

Features

- Complete solution for coil-on-plug applications
- Integrates control circuit, IGBT, passives
- 400 V clamp voltage; 12 A IGBT collector current
- 250 mJ IGBT collector-emitter avalanche energy
- ESD, EMC, ISO pulse: ISO7637-2
- SIP-5J package

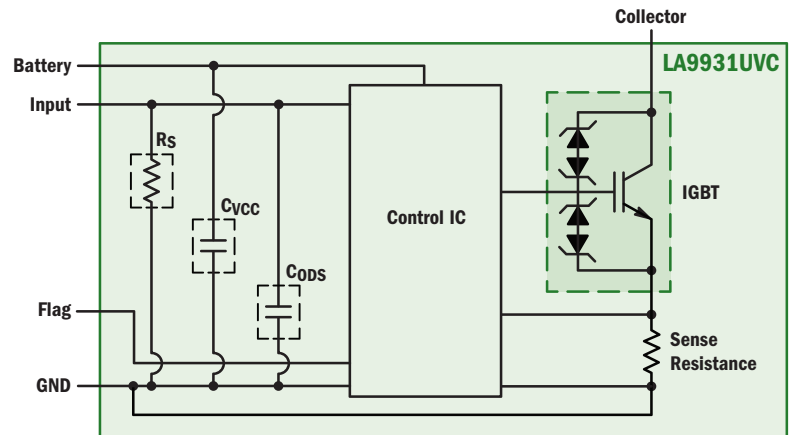

Ignition IGBTs

Features

- Stand alone Ignition IGBTs with integrated collector - gate clamp and ESD protection
- Wide product portfolio including customized die/ wafer solutions
- Smart Ignition solutions including
 - Current sense IGBT
 - Integrated control IC
 - Stand alone Ignition control IC
 - Fully integrated Igniter custom solutions

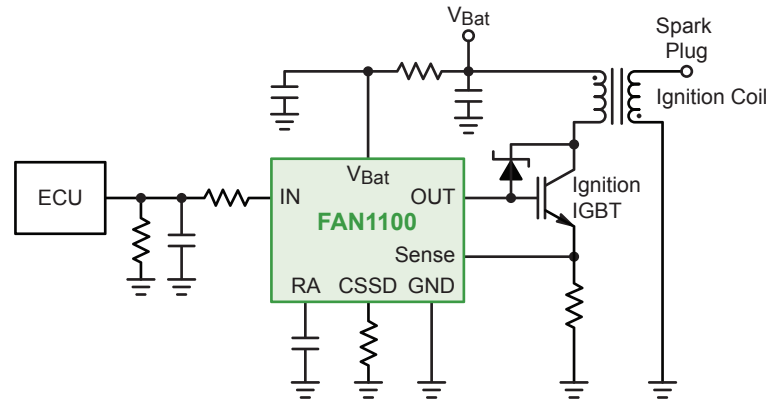

Device	Clamp Voltage (V)	SCIS Energy (mJ)	I _c @ 25°C	V _{CE(sat)} @ 25°C Max	Package
FGBS3040E1-F085*	400	300	16.5 A	1.60 V	T0-263-7
FGB3040CS**	400	300	21 A @ 4 V	1.60 V @ 6 A	T0-263-6
FGB3056-F085	560	300	29 A @ 5 V	1.60 V @ 8 A	T0-263
FGD3050G2	500	300	32 A @ 5 V	1.20 V @ 6 A	T0-252
FGB3245G2-F085	450	320	26 A @ 4 V	1.25 V @ 6 A	T0-263
FGD3245G2-F085	450	320	26 A @ 4 V	1.25 V @ 6 A	T0-263
ISL9V5045S3ST-F085	450	500	51 A @ 4 V	1.60 V @ 10 A	T0-263
FGB3440G2-F085	400	335	27 A @ 4 V	1.20 V @ 6 A	T0-263
FGD3440G2-F085	400	335	27 A @ 4 V	1.20 V @ 6 A	T0-252
FGP3440G2-F085	400	335	27 A @ 4 V	1.20 V @ 6 A	T0-220
FGB3040G2-F085	400	330	41 A @ 5 V	1.25 V @ 6 A	T0-263
FGD3040G2-F085	400	330	41 A @ 5 V	1.25 V @ 6 A	T0-252
FGI3040G2-F085	400	330	41 A @ 5 V	1.25 V @ 6 A	T0-252
FGP3040G2-F085	400	330	41 A @ 5 V	1.25 V @ 6 A	T0-220
ISL9V3040P3	400	300	21 A @ 4 V	1.60 V @ 6 A	T0-220
ISL9V3040S3ST	400	300	21 A @ 4 V	1.60 V @ 6 A	T0-263
ISL9V3040D3ST	400	300	21 A @ 4 V	1.60 V @ 6 A	T0-252
ISL9V2040S3ST	400	200	10 A @ 4 V	1.90 V @ 6 A	T0-263
ISL9V2040D3ST	400	200	10 A @ 4 V	1.90 V @ 6 A	T0-252
ISL9V2540S3ST	400	250	15 A @ 4 V	1.90 V @ 6 A	T0-263
FGD2736G3-F085	360	270	21 A @ 5 V	1.35 V @ 6 A	T0-252
FGB3236-F085	360	320	44 A @ 4 V	1.40 V @ 6 A	T0-263
FGI3236-F085	360	320	44 A @ 4 V	1.40 V @ 6 A	T0-263
ISL9V5036S3ST	360	500	46 A @ 4 V	1.60 V @ 10 A	T0-263
ISL9V5036S3	360	500	46 A @ 4 V	1.60 V @ 10 A	T0-262
ISL9V5036P3-F085	360	500	46 A @ 4 V	1.60 V @ 10 A	T0-220
ISL9V3036S3ST	360	300	21 A @ 4 V	1.60 V @ 6 A	T0-263
FGD3325G2-F085	250	330	41 A @ 5 V	1.25 V @ 6 A	T0-252

* Current sense; max dwell; soft shut-down. ** Current sense.

High Voltage Power Modules

HVIC

- 2 A source / 4 A sink
- fpwm up to 20 kHz
- UVLO protection

Diode

- Soft recovery for easy drive and low EMI

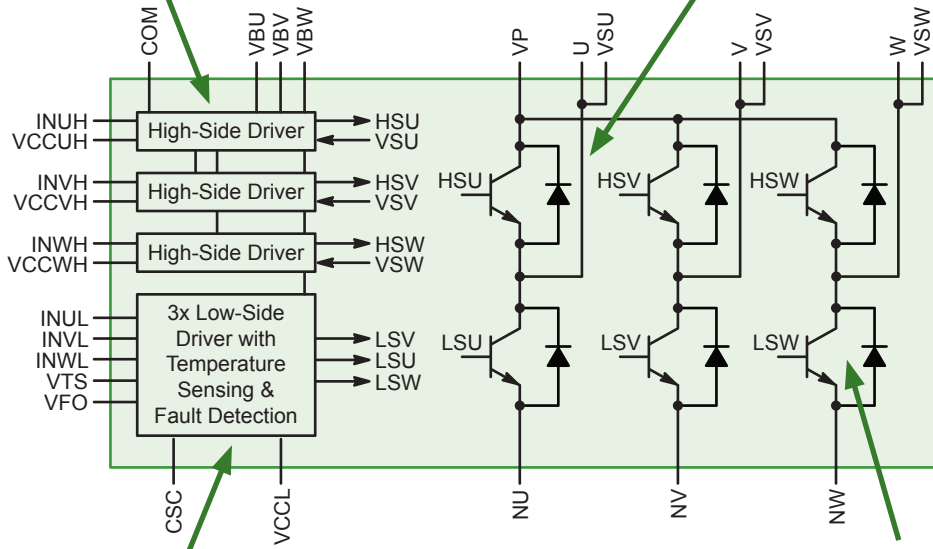

LVIC

- 2 A source / 4 A sink
- fpwm up to 20 kHz
- Protection UVLO, OCP, TSU Fault out
- Thermal Sensing 0°C~150°C via Vts

Features

- Ultra low Rth (<0.34°C/W) via outstanding substrate DBC
- Guaranteed Tj = 175°C
- Outstanding ruggedness via SCWT is over 5 μs @ worst case
- Reduced design cycle & assembly process as IPM fully optimized for stable EMI & thermal performance

IGBT

- Low conduction and switching losses
- Optimized switching dv/dt for motor control
- Short circuit rated

Device	Series	BV (V)	Current Rating @ 100°C (A)	Gate Driver	Rth(j-c) Max (°C/W)	Substrate	Package
NFVA25012NP2T*	ASPM34	1200	50	Integrated	0.4	AIN	SPM-34
NFVA23512NP2T*	ASPM34	1200	35	Integrated	0.73	Al ² O ³	SPM-34
NFVA22512NP2T*	ASPM34	1200	25	Integrated	0.81	Al ² O ³	SPM-34
NFVA35065L32	ASPM27	650	50	Integrated	0.34	AIN	SPM-27
NFVA34065L32*	ASPM27	650	40	Integrated	1.19	Al ² O ³	SPM-27
NFVA33065L32*	ASPM27	650	30	Integrated	1.4	Al ² O ³	SPM-27

* Pending 4Q18.

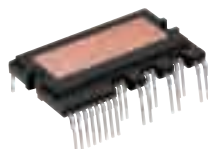

SPM-27



SPM-34

Charge Pumps for Power Supplies

Charge Pump Regulators are flexible devices providing buck, boost or buck/boost conversion. The main advantage of using charge pump architectures is an inductor is not required, reducing application cost and design effort compared to SMPS converters utilizing an inductor. Charge pumps are suitable for applications where an LDO dissipates too much power or boost (or buck/boost) operation is mandatory.

Main Features of Automotive Charge Pumps

Small components count and PCB area

- No inductor needed
- Works with ceramic capacitors

Variable topology

- Buck or Pass mode (LDO)
- Boost
- Buck/Boost

Efficiency

- Twice as efficient compared to LDO solution

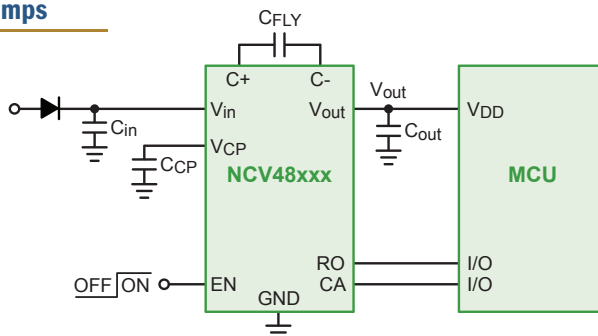

The NCV48xxx charge pump portfolio includes buck, boost, and buck/boost architectures with various output current and features. Compared to charge pumps on market, specific feature of used architectures is access to charge pump output allowing its voltage limitation during battery voltage transients (e.g. Load Dump). This feature enables placing lower voltage rating bulk capacitor at the charge pump output, and reduces overall application cost. Current limitation function inrush current charging reduces the bulk capacitor size as well.

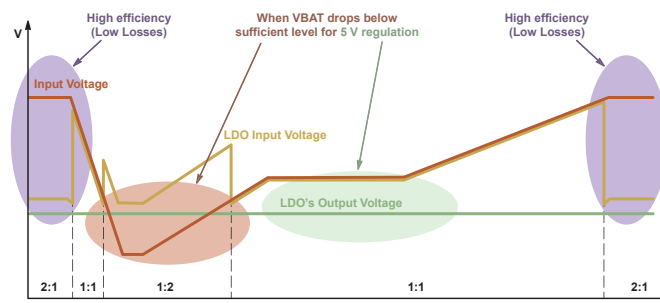

Buck, Boost and Pass (LDO) Operation Modes

Additional features such as Reset Output (RO) and Charge Pump Active Output (CA, optional feature) are available for communication with MCU.

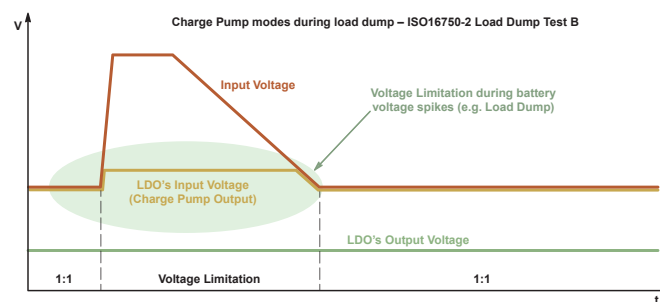

Charge Pump Output Voltage Limitation during Load Dump

Comparison of Battery Connected LDO, Charge Pump and SMPS

Converter Type	Efficiency	Output Current	Inductor	Buck (or LDO)	Boost	Buck/Boost
LDO	Low	Low		✓		
Charge Pump	Middle	Middle		✓	✓	✓
SMPS	High	High	✓	✓	✓	✓

Battery Connected Charge Pump

Device	Buck	Boost	Pass Mode LDO	Output Current in Buck Mode	Output Current in Boost Mode	Output Current in Pass Mode	Fsw	Output Voltage	Tolerance	Sleepmode Current (Max)	Quiescent Current (Max) @ Low Load (Load)	Enable	Reset	Charge Pump Active Output	Peak Transient (V)	Package
NCV48220		✓	✓		Up to 150 mA	Up to 150 mA	450 kHz	5 V	±2%	1 µA	40 µA (100 µA)	✓	✓		45	S0-8

Switch Mode Power Supplies (SMPS)

Boost SMPS

- Standard Regulators
- Standard Controllers

Buck SMPS

- Standard Regulators
- Low Iq Regulators
- Multi-Megahertz Regulators
- Standard Controllers
- Low Iq Controllers

Boost SMPS

The NCV887x and NCV89803x portfolio of adjustable output, non-synchronous boost controllers drive an external N-channel MOSFET. The devices use peak current mode control with internal slope compensation. These boost products incorporate an internal regulator that supplies charge to the gate driver. Designed for powertrain, start-stop, and display applications, the devices can be configured as a SEPIC converter to regulate the car battery voltage, which can vary from 4.5-18 V to a regulated output of 6 V in an engine ECU. Any boost controller can also be configured as a boost converter, to boost the battery voltage from 4.5-18 V to an output voltage of 55-65 V, to power the injectors of direct gasoline injection systems.

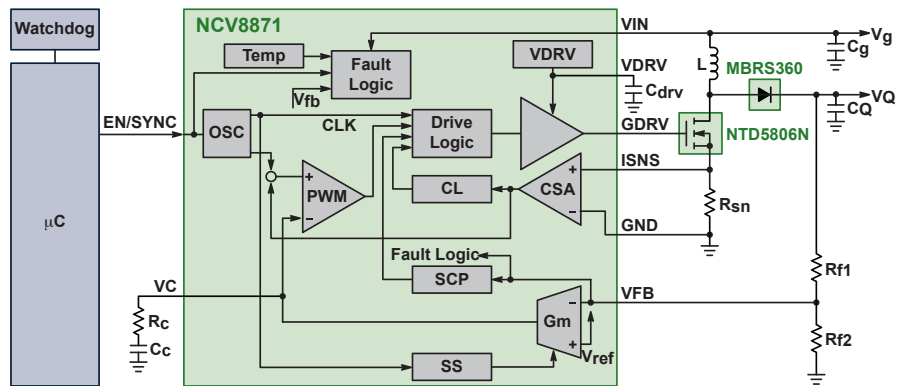
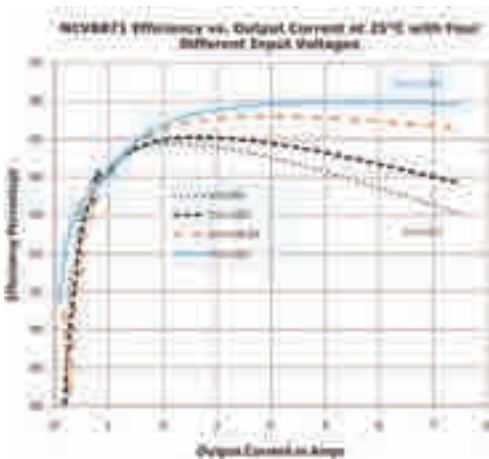

Buck SMPS

ON Semiconductor is developing high efficiency, high frequency switch mode power supplies that can withstand automotive load transients up to 45 V. The high switching frequencies enable the devices to provide the entire buck solution in a very small foot print, by meeting the stringent EMC/EMI performance required in powertrain applications. The SMPS buck regulator portfolio has expanded for 2 MHz operation with high output current capability (up to 3A for regulators and much more for controllers).

The NCV891x34 is a dual mode regulator intended for battery-connected applications that must operate up to a 45 V input supply. Hybrid Low Power Mode allows the NCV891x34 to operate either as a PWM buck converter, or as a low drop-out linear regulator, and the NCV891x34 is suitable for systems with low noise and low quiescent current requirements, often encountered in automotive driver information systems. In addition to synchronization and protection features, the high switching frequency produces low output voltage ripple, even when using small inductor values and an all-ceramic output filter capacitor – forming a space-efficient switching regulator solution.

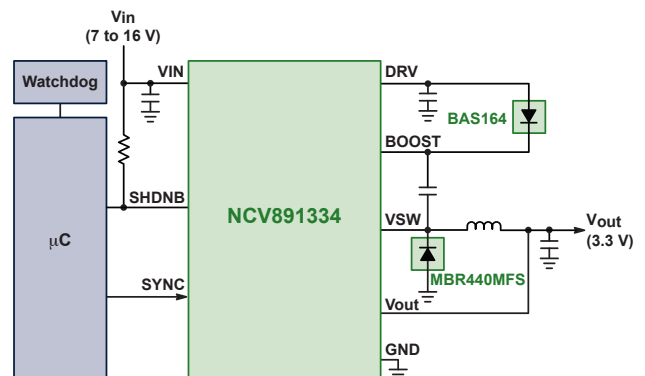

Battery-Connected SMPS Power Management Units (PMUs)

The NCV9731x is a high-frequency multi-output regulator consisting of one battery-connected non-synchronous buck regulator with a user-selected low- I_q linear standby mode, and two low-voltage synchronous buck regulators.

Features

- 2 MHz switching frequency
- Operation down to 4.1 V input
- Withstands 45 V load dump
- Downstream buck regulators adjustable from 1.2 V to 3.3 V
- 3 independent reset pins
- -40 °C to 150°C operation

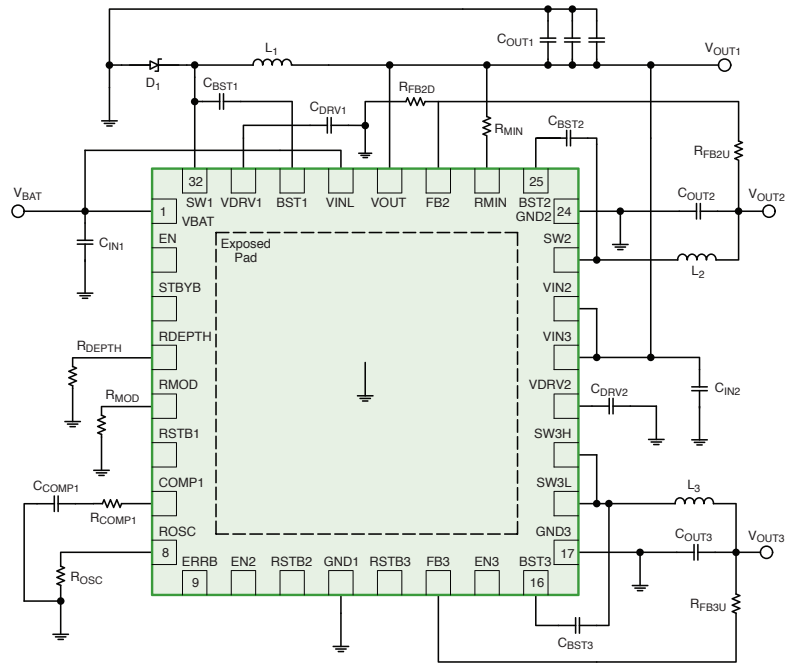

Device	Type	I_q Max (V)	Outputs	Primary Output (V)	Spread Spectrum	OVSD Threshold Max (A)	Package(s)
NCV97310	Switching	25	3	3.3 or 5.0	Yes	36	QFN-32 EP
NCV97311	Switching	25	3	3.3 or 5.0	Yes	40	QFN-32 EP

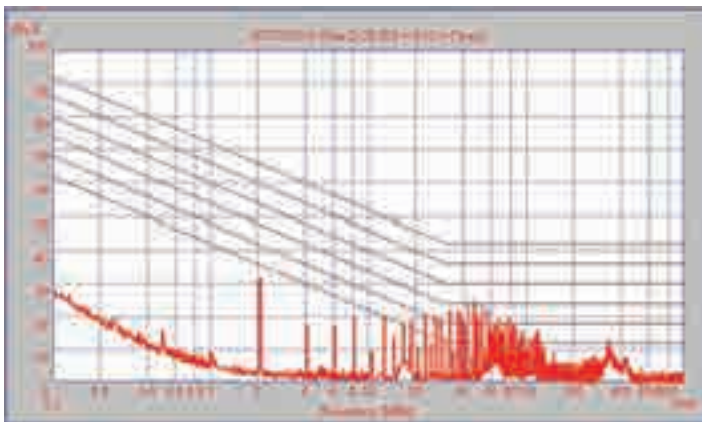

Typical Emissions Profile

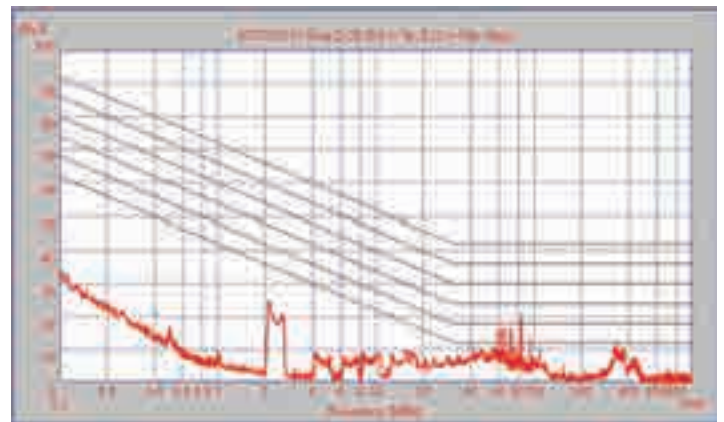

Emissions with Spread Spectrum

Battery-Connected SMPS Power Management Units (PMUs)

The NCV97400 is a synchronous 4-output monolithic regulator consisting of 3 buck regulators and 1 boost regulator, with supervisory functions including window voltage monitoring on all outputs and a window watchdog. This device is ideal for ADAS (Advanced Driver Assistance Systems) applications, and utilizes an independent voltage reference and an adjustable independent oscillator to realize the supervisory features.

Features

- 4 outputs
- 3.3 V primary buck which delivers up to 3 A
- 5 V boost to supply, for example, IVN circuits
- 2 adjustable secondary bucks (0.8 V .. 3.3 V) which deliver up to 2 A
- 3 Enabled Buck Converters
- Voltage monitoring
- Wide input of 4.1 to 40 V with Undervoltage Lockout (UVLO)
- 2 MHz operation with spread spectrum capability
- Window Watchdog with independent references
- ISO26262 ready

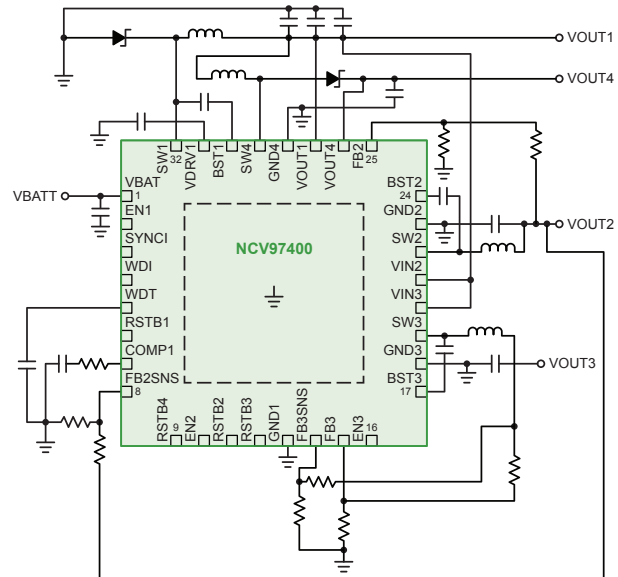

The NCV97200 is a synchronous 2-output monolithic regulator consisting of 1 buck regulator and 1 boost regulator, with supervisory functions including window voltage monitoring on all outputs and a window watchdog. This device is ideal for ADAS (Advanced Driver Assistance Systems) applications and utilizes an independent voltage reference and an adjustable independent oscillator to realize the supervisory features.

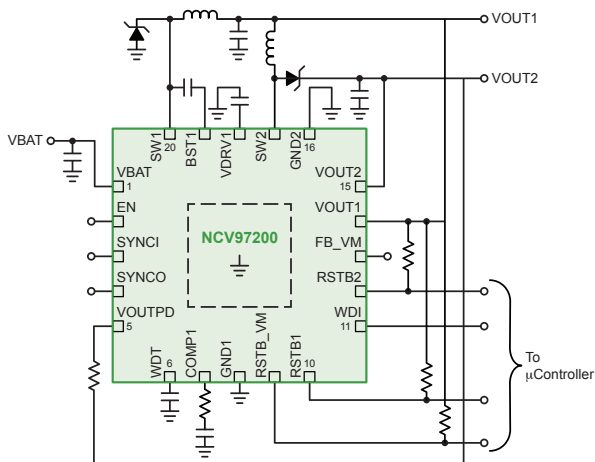

Features

- 3.3 V primary buck which delivers up to 3 A
- 5 V boost to supply, for example, IVN circuits
- 1 Boost Converter for IVN supply
- Wide input of 4.1 to 40 V with Undervoltage Lockout (UVLO)
- 2 MHz operation with spread spectrum capability
- Window Watchdog with independent references
- ISO26262 ready

Battery-Connected Buck SMPS for Primary Power Conversion

The 2 MHz NCV890xxx and NCV891xxx portfolio removes the need for EMI countermeasures and reduces the number of required external components in automotive power supplies. The devices achieve output as low as 3.3 V from an 18 V input, without pulse skipping. A wide range of output currents and features is available.

Features

- Maximum DC current from 0.6 A to 3 A
- Load dump capability: 40 V and 45 V versions
- Synchronization input: use an external clock or synchronization output in order to override internal switching frequency
- Synchronization output: allows the synchronization of another power supply or other device
- Power Good: Open drain output; high when output voltage is above power good threshold
- Reset: Open drain output; high when output voltage is above reset threshold, and has a programmable delay
- Spread spectrum: Internally generated spread spectrum, with both the modulation frequency and modulation depth externally programmable
- Low I_q: some versions have low I_q in light load conditions
- Standard features: Under-voltage lock-out, frequency fold back, peak current limit, thermal shut down, and low I_q sleep mode

Device	DC Current Max (A)	Sync	Load Dump (V)	I _q (μA)	Package(s)
NCV891330	3.0	Yes	45	30	SOIC-8
NCV890201	2.0	Yes	40	–	DFN-10
NCV890231	2.0	Yes	45	–	DFN-10
NCV890131	1.2	Yes	45	–	DFN-10
NCV890130	1.2	No	45	–	DFN-8
NCV890101	1.2	Yes	40	–	DFN-10
NCV891130	1.2	No	45	30	SOIC-8
NCV890100	1.2	No	40	–	DFN-8, SOIC-8 EP
NCV890430	0.6	Yes	45	–	DFN-8

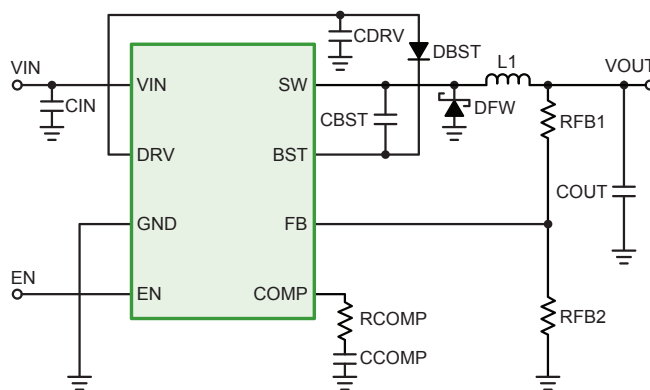

Low Voltage Buck SMPS and PMU for Secondary Power Conversion

Supplied from a pre-regulated voltage rail, the low voltage buck SMPS and PMU support a wide variety of end applications such as clusters, cameras, radars and other peripherals.

NCV6323, NCV6324 – 2 A PFM/PWM Buck

NCV6323 and NCV6324 are adjustable monolithic synchronous buck converters with integrated power stage. They are able to deliver up to 2 A DC and operate in forced PWM (NCV6323) or in automatic PFM/PWM (NCV6324) for optimized low load efficiency. The devices come in a small DFN package, and the 3 MHz switching frequency allows the use of small size inductors and capacitors. They are therefore ideally suited for space constrained applications.

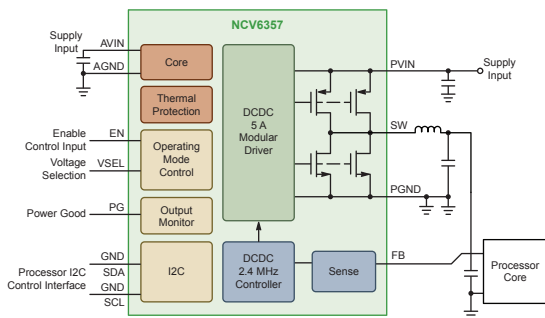
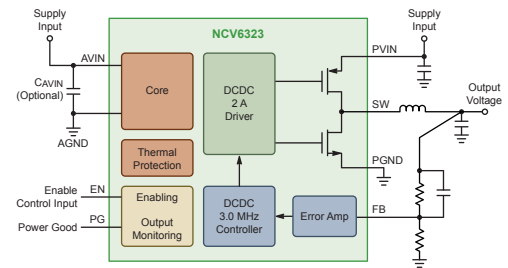

NCV6356, NCV6357 – 5 A AOT Buck

NCV6356 and NCV6357 are programmable monolithic synchronous buck converters with integrated power stage and dynamic voltage scaling support. They are able to deliver up to 3 A DC at 105°C ambient and up to 6 A of peak current. Their adaptive constant-on-time architecture allows for the use of low valued inductors and provides a very fast transient load response (20 mV/1.5 A/500 ns) which makes them ideally suited for high performance applications. The NCV6356 comes with I2C and Interrupt pin; the NCV6357 with I2C and Power Good pin.

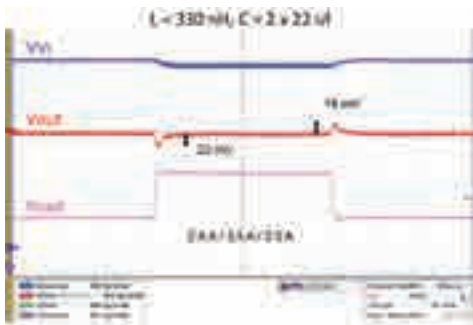

NCV6922 – PMU 2 Buck 2 LDO

The NCV6922 is a low voltage PMU including 2 buck converters of 800 mA and 2 low dropout, low noise regulators of 200 mA. The device is fully programmable through I2C and also through factory programming. Virtually all power up sequence and output voltage combination can be created. The NCV6922 is ideally suited for surround and rearview camera designs in conjunction with ON Semiconductor image sensors.

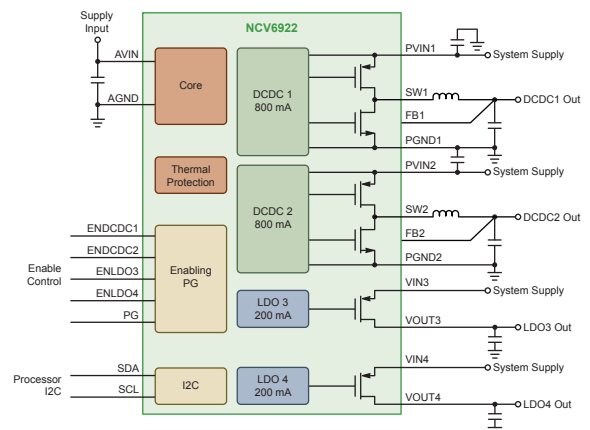

Boost/Flyback/SEPIC SMPS Controllers

The highly flexible NCV8871, NCV8873, and NCV89803x controllers provide compact, easy to use, cost effective lighting solutions for boost, flyback, and SEPIC topologies. The devices operate over a wide input battery voltage range (3.2 V to 45 V), and feature a low shutdown current of under 10 μ A.

The NCV8871 and NCV8873 devices have factory programmable switching frequencies from 170 kHz to 1 MHz. The NCV8873 feedback voltage is set to 0.2 V in order to better fit applications where constant current regulation is desired, such as LED drivers. The NCV89803x has a set switching frequency of 2 MHz, which permits the use of smaller filter components for a lower cost system solution.

These devices provide integrated current limit, thermal shutdown, and under-voltage lockout, and are rated from -40°C to 150°C junction temperature.

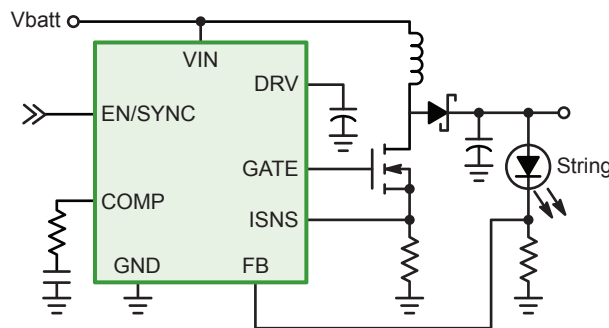

NCV8871xx Backlighting PWM Deep Dimming Application - Minimal External Components

Additional performance combinations available with rapid prototyping. Factory programmable features:

- Fsw: 170 kHz to 1 MHz for NCV887x;
170 kHz to 2 MHz for NCV89803x
- Minimum on-time
- Max duty cycle
- Slope compensation
- Current limit
- Gate drive voltage
- Gate drive strength



Low Dropout Buck SMPS for System Supply

NCV8852 and NCV8853 adjustable-output non-synchronous buck controllers drive an external P-channel MOSFET. The devices use peak current mode control with internal slope compensation, and incorporate an internal regulator that supplies charge to the gate driver.

Features

- Ultra low I_q sleep mode
- Adjustable output with 800 mV ±2% reference voltage
- Wide input of 3.1 to 44 V
- Internal Soft-Start
- Undervoltage lockout
- External frequency synchronization
- 100% max duty cycle
- Programmable cycle-by-cycle current limit
- Hiccup overcurrent protection
- Hiccup short circuit protection

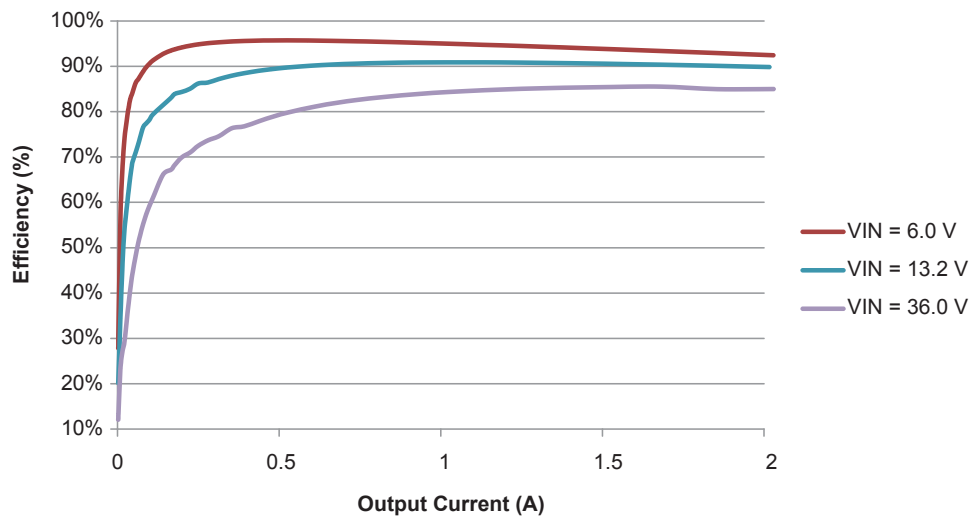
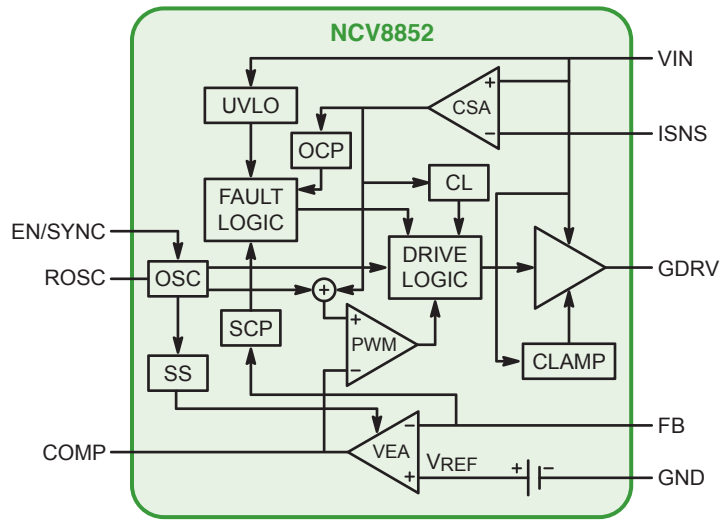

Pre-Boost Controllers for Low Battery Conditions

The NCV887xxx portfolio comprises a Non-Synchronous Pre-Boost controller family designed to supply a minimum output voltage during Start-Stop vehicle operation and other battery voltage sags. The controllers drive an external N-channel MOSFET.

Features

- Wide Input Voltage Range of 2 V to 40 V, 45 V Load Dump
- Automatic Enable Below Wake Up Threshold Voltage (Factory Programmable)
- Factory programmable frequency options or frequency adjust resistor option
- Boost Mode Operation at Regulation Set Point
- 2% Output Accuracy Over Temperature Range
- Peak Current Mode Control with Internal Slope Compensation
- Low Quiescent Current in Sleep Mode (<12 μ A Typical)

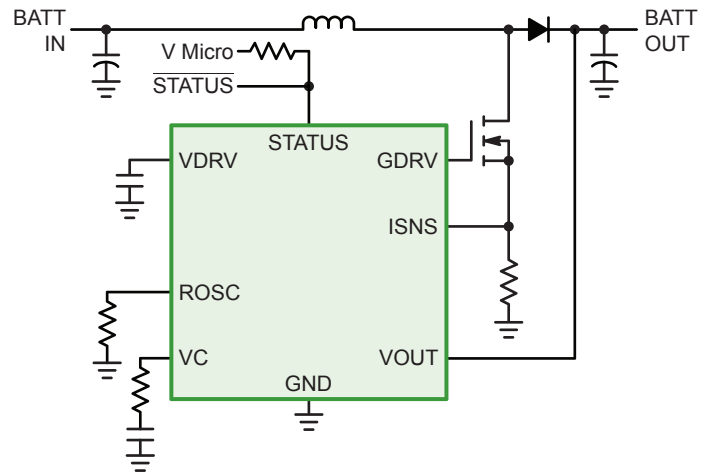

NCV887600 Simplified Application

Device	V _{out} (V)	Frequency (kHz)	Slope Compensation (mV/ μ s)	Current Limit (mV)	Osc Frequency Adjust	Status Pin	Disable Pin	Package(s)
NCV887600	6.8	170	34	400	✓	✓		SOIC-8
NCV887601	6.8	170	53	200	✓	✓		SOIC-8
NCV887700	6.8	170	34	400	✓		✓	SOIC-8
NCV887701	6.8	170	53	200	✓		✓	SOIC-8
NCV887720	10	170	53	200	✓		✓	SOIC-8
NCV887740	12	170	53	200	✓		✓	SOIC-8
NCV887801	6.8	450	53	200		✓	✓	SOIC-8

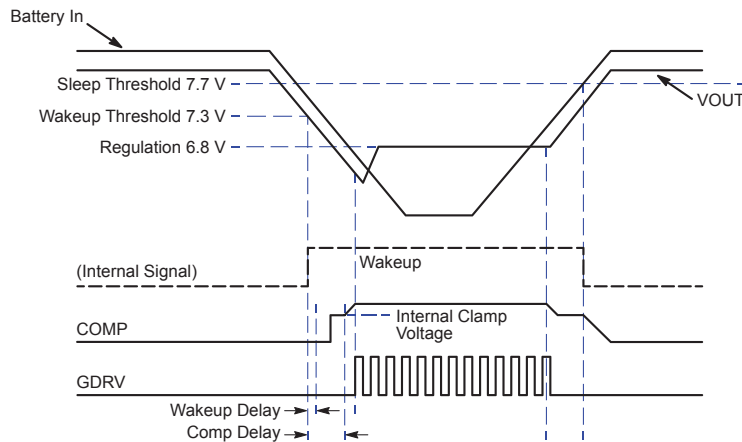

Typical Output Waveforms Through Battery Cranking Profile

Current Sense LDO and High Side Switch Applications

Current sense LDO linear voltage regulators and High Side Switches (HSS) provide precise current limiting, which can be adjusted for particular application requirements. These devices provide diagnostic information to control MCUs, either as analog or digital outputs, enabling the MCU to implement required steps (e.g., switch off the LDO or HSS with overloaded or unloaded output, or short to battery). Both current sense and diagnostic features are particularly useful for off-the-module loads, when it is necessary to know the status of an external load and take appropriate actions. Typical applications are: active antenna, camera module and microphone. Current sense LDOs and HSS also provide reverse battery, reverse bias, short-to-battery, short-to-ground, and thermal shutdown protection features.



The current limit of the device is adjustable by a resistor connected to CSO pin. The current flowing out of CSO pin is proportional to the output current, and its guaranteed ratio and precision is shown in the table Current Sense Regulators/Switches. This information can be processed by ADC converter of MCU. Error Flag is open collector output and it provides digital signal to MCU indicating open load, overcurrent, short to ground or short to battery information, and it can be processed by digital input of MCU.

The NCV47xx0 and NCV47xx1 product families are Current Sense LDOs with analog or analog/digital diagnostics. These are primarily used for supplying active antennae or microphones.

The NCV47xx2 product families are Current Sense HSS parts with analog and digital diagnostics. These are primarily used for supplying out of module loads (e.g. camera module).

The NCV47xx3 product families are Current Sense HSS/Constant Current parts with analog and digital diagnostics. These parts have enhanced current limitation features eliminating input inrush current and very low reverse bias currents, and are primarily used for supplying out of module loads (e.g. camera module) or constant current loads (e.g. LEDs). Only RCSO is required for current limitation.

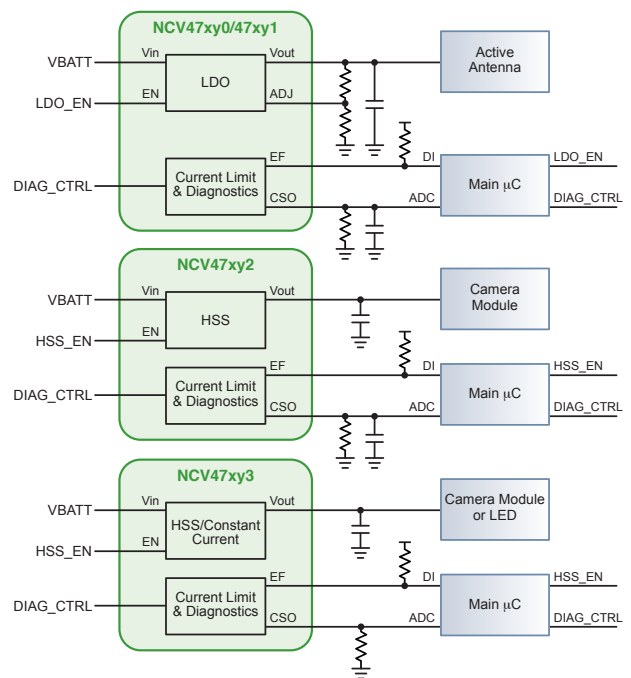

Current Sense Regulators/Switches

Device	Output Current (mA)	Output Voltage (V)	Dropout Max (mV)	Sleepmode Current Max (µA)	Quiescent Current (Max) @ Low Load (Load)	Current Mirror Precision	Current Mirror Ratio	Error Flag	Package(s)
NCV47551	20	Adj	500	10	380 µA (100 µA)	±10%	1:1		SOIC-8
NCV47411	2x 100	Dual Adj	550	10	370 µA (500 µA)	±10%	50:1		TSSOP-14 EP
NCV47721	200	Adj	500	10	1 mA (500 µA)	±5%	100:1	✓	TSSOP-14 EP
NCV47821	2x 200	Dual Adj	500	10	1 mA (500 µA)	±5%	100:1	✓	TSSOP-14 EP
NCV47722	250	High Side Switch	400	10	1.3 mA (500 µA)	±5%	300:1	✓	TSSOP-14 EP
NCV47822	2x 250	Dual High Side Switch	400	10	1.5 mA (500 µA)	±5%	300:1	✓	TSSOP-14 EP
NCV47823	2x 250	Dual HSS/Constant Current	400	20	1.5 mA (500 µA)	±5%	300:1	✓	TSSOP-14 EP
NCV47700/10/01/11	350	Adj	500	10	230 µA (1 mA)	±10%	100:1		SOIC-8, SOIC-8 EP

Watchdog and Tracking LDOs for Power Supplies

Watchdog LDOs

Watchdog LDOs from ON Semiconductor deliver 150 to 250 mA load current, and provide supervision of an external single sided or window watchdog, for microcontroller-based automotive applications. The portfolio provides integrated protection features, such as peak transients, current limit, thermal shutdown, and in most cases allows -40°C to 150°C operating junction temperature.

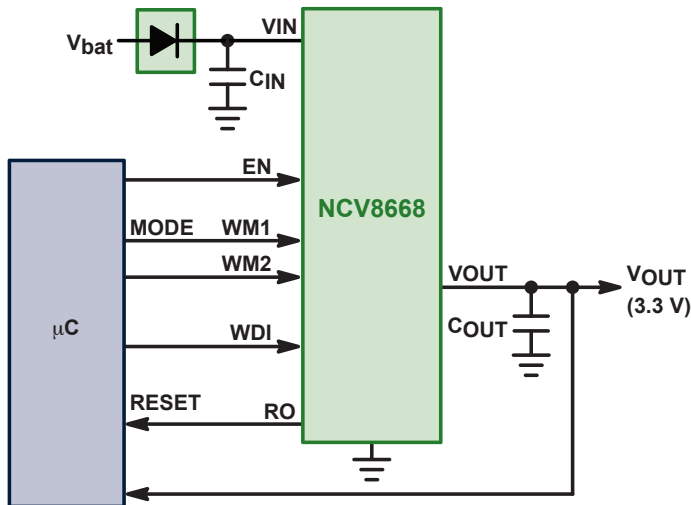

The NCV8518B 250 mA LDO voltage regulator incorporates a watchdog feature which continuously monitors the WDI input from the microprocessor in order to determine the output state.

The NCV8668 and NCV8768 are 150 mA LDO regulators that feature low typical I_q of 38 μ A and 31 μ A respectively during sleep mode, and include window watchdog functionality.

Tracking LDOs

Engine controllers must provide fully regulated, buffered power supply rails to power external sensors. Also known as tracking regulators, these devices must be fully protected from external faults, such as short to GND, short to battery, and reverse battery; and should still provide regulated output with very close tracking of the reference voltage. ON Semiconductor offers a wide range of single and dual tracking regulators – including CS8182, CS8361, NCV8184, and NCV4250-2C – with various output current and package options for automotive engine controller applications.

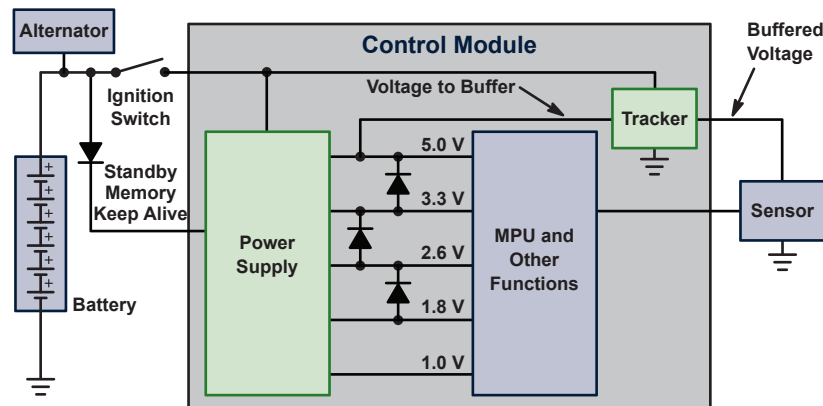

Buffering Voltage to Send it Outside of a Module to a Sensor

Wide Selection of Automotive Qualified Linear Regulators

Post Regulation Linear Regulators

Device	Output Current	Output Voltage (V)	Dropout Max	Sleepmode Current Max (µA)	Quiescent Current (Max) @ Low Load (Load)	Tolerance (%)	Enable	Package(s)
NCV8715	50 mA	1.2, 1.5, 1.8, 2.5, 3.0, 3.3, 5.0	260 mV	–	4.7 µA	±2		XDFN-6
NCV8716	80 mA	1.5, 1.8, 2.5, 3.0, 3.3, 5.0	400 mV	–	4.7 µA	±2		WDFN-6
NCV662	100 mA	1.5, 1.8, 2.5, 2.7, 2.8, 3.0, 3.3, 5	300 mV	1	6 µA (1 mA)	±4	✓	SC-82
NCV663	100 mA	1.5, 1.8, 2.5, 2.7, 2.8, 3.0, 3.3, 5	300 mV	–	6 µA (1 mA)	±4		SC-82
NCV78LxA	100 mA	5, 8, 12, 15, 24	1.7 V (Typ)	–	–	±4		SOIC-8, TO-92
NCV551	150 mA	1.4, 1.5, 1.8, 2.5, 2.7, 2.8, 3.0, 3.1, 3.2, 3.3, 5	220 mV	1	8 µA (1 mA)	±3	✓	TSOP-5
NCV571	150 mA	0.8, 0.9, 1.0, 1.2	450 mV	1	8 µA (150 mA)	±4	✓	TSOP-5, DFN-6
NCV8560	150 mA	Adj., 1.3, 1.5, 1.8, 2.5, 2.8, 3.0, 3.3, 3.5, 5	125 mV	1	180 µA (150 mA)	±2	✓	DFN-6, TSOP-5
NCV8152	150 mA	1.8/2.8, 2.8/1.8, 3.0/1.8, 3.3/1.8	140 mV	1	50 µA (100 µA)	±3	✓	XDFN-6
NCV8170	150 mA	1.2, 1.5, 1.8, 2.5, 2.8, 3.0, 3.1, 3.3,	350 mV	1	50 µA (90 µA)	±2	✓	XDFN-4, SOT-563
NCV8702	200 mA	1.8, 2.8, 3.0, 3.3	140 mV	1	60 µA (1 mA)	±2	✓	DFN-6, TSOP-5
NCV8570B	200 mA	1.8, 2.5, 2.8, 3.0, 3.3	155 mV	1	75 µA (1 mA)	±2	✓	DFN-6, TSOP-5
NCV8752	200 mA	1.8, 2.8, 3.0, 3.3	140 mV	1	12 µA	±2	✓	XDFN-6, TSOP-6
NCV8160	250 mA	1.8, 2.5, 2.8, 2.9, 3.0, 3.3	90 mV	1	18 µA	±2	✓	XDFN-4
NCV8163	250 mA	1.2, 1.5, 1.8, 2.1, 2.5, 2.8, 3.0, 3.3	80 mV	1	12 µA	±2	✓	XDFN-2
NCV8703	300 mA	1.8, 2.8, 3.0, 3.3	180 mV	1	60 µA (1 mA)	±2	✓	DFN-6, TSOP-5
NCV8114	300 mA	1.2, 1.5, 1.8, 2.5, 2.8, 3.0, 3.3	135 mV	1	55 µA (95 µA)	±2	✓	TSOP-5
NCV8154	300 mA	3.0/3.0, 3.3/1.8, 1.8/2.8, 3.3/3.3	140 mV	1	55 µA (100 µA)	±3	✓	DFN-10
NCV8718	300 mA	Adj.	300 mV	1	4 µA	±2	✓	WDFN-6
NCV8130	300 mA	0.8, 1.0, 1.1, 1.2, 1.3, 1.5, 1.8	150 mV	1	80 µA	±1.5	✓	XDFN-6
NCV8720	350 mA	1.0, 1.05, 1.10, 1.15, 1.2, 1.25, 1.3, 1.4, 1.45	110 mV	1	–	±2	✓	WDFN-6
NCV8161	450 mA	1.8, 2.5, 2.8, 2.9, 3.0, 3.3	225 mV	1	18 µA	±2	✓	XDFN-4
NCV78MxA	500 mA	5	**	–	**	±4		DPAK-3
NCV5501	500 mA	1.5, 3.3, 5	700 mV	–	500 µA (100 µA)	±4.9		DPAK-3
NCV5500	500 mA	Adj. 1.5, 3.3, 5	700 mV	50	500 µA (100 µA)	±4.9	✓	SOIC-8, DPAK-5
NCV8133	500 mA	0.8, 1.0, 1.1, 1.2, 1.3, 1.5, 1.8	140 mV	1	80 µA	±1.5	✓	XDFN-6
NCV8535	500 mA	Adj. 1.5, 1.8, 2.5, 2.8, 2.85, 3.0, 3.3, 5	340 mV	1	190 µA (100 µA)	±1.5	✓	DFN-10
NCV8537	500 mA	Adj. 1.8, 2.5, 3.3, 5.0	340 mV	1	190 µA (100 µA)	±1.5	✓	DFN-10
NCV8177	500 mA	0.75, 1.2, 1.5, 1.8, 2.5, 3.3,	200 mV	–	60 µA (90 µA)	±2	✓	XDFN-4
NCV33269	800 mA	Adj. 3.3, 5, 12	1.35 V	–	–	±2		DPAK-3
NCV78xA	1 A	5, 12	**	–	–	±4		D2PAK-3, TO-220
NCV8186	1 A	1.2, 1.75, 1.8, 1.85, 2.5, 2.8, 3.3, 3.5, 3.9	100 mV	–	90 µA (140 µA)	±1	✓	XDFN-8
NCV1117	1 A	Adj. 1.5, 1.8, 2, 2.5, 3.3, 5, 12	1.2 V	–	–	±2		DPAK-3, SOT-223
NCV5661	1 A	Adj. 1.2, 1.5, 1.8, 2.5, 2.8, 3.0, 3.3	1.3 V	300	–	±2	✓	DPAK-5, DFN-6
NCV59152	1.5 A	Adj. 1.8, 2.5, 2.8, 3.0, 3.3, 5.0	500 mV	5	–	±1.5	✓	DFN-8, D2PAK-3, D2PAK-5
NCV59748	1.5 A	Adj.	60 mV	–	–	±2	✓	DFN-10
NCV5662	2 A	Adj. 1.5	1.3 V	300	–	±2	✓	D2PAK-5
NCV59744	3 A	Adj.	115 mV	–	–	±2	✓	QFN20
NCV59302	3 A	Adj. 1.8, 2.5, 2.8, 3.0, 3.3, 5.0	500 mV	5	–	±2	✓	D2PAK-5
NCV5663	3 A	Adj. 1.5	1.3 V	300	–	±2	✓	D2PAK-5

** See data sheet for details.

Tracking Regulators

Device	Output Voltage (V)	Tolerance	Output Current (mA)	Dropout Max (V)	Sleepmode Current Max (µA)	Quiescent Current (Max) @ Low Load (Load)	Enable	Reset	Dropout (Max)	Package(s)
NCV4250-2C	Tracking	±5 mV	50	0.3	20	150 µA (1 mA)	✓		45	TSOP-5
NCV8184	Tracking	±3 mV	70	0.6	20	70 µA (100 µA)	✓		45	SOIC-8, SOIC-8 EP, DPAK-5
CS8182	Tracking	±10 mV	200	0.6	55	150 µA (100 µA)	✓		45	DPAK-5, D2PAK-5, SOIC-8
CS8361	Tracking 5	±25 mV ±2%	250 100	0.7 0.6	200	200 µA (300 µA)	✓	✓	60	D2PAK-7, SOIC-16W

Wide Selection of Automotive Qualified Linear Regulators

Battery Connected Linear Regulators

Device	Output Current	Output Voltage (V)	Dropout Max (V)	Sleepmode Current Max (μ A)	Quiescent Current (Max) @ Low Load (Load)	Tolerance (%)	Enable	Package(s)
NCV4294C	30 mA	3.3, 5	0.25	–	170 μ A (100 μ A)	\pm 4		TSOP-5
NCV4295C	30 mA	3.3, 5	0.25	–	170 μ A (100 μ A)	\pm 4		TSOP-5
NCV4296-2C	30 mA	3.3, 5	0.25	1	170 μ A (100 μ A)	\pm 4	✓	TSOP-5
NCV4949C	100 mA	5	0.5	–	260 μ A (300 μ A)	\pm 2		SOIC-8, SOIC-8 EP
NCV2951A	100 mA	Adj, 3.3, 5	0.45	–	120 μ A (100 μ A)	\pm 1.5	✓	SOIC-8
NCV317L	100 mA	Adj	1.9 (Typ)	–	–	\pm 4		SOIC-8, TO-92
NCV4299C	150 mA	3.3, 5	0.5	1	95 μ A (100 μ A)	\pm 2	✓	SOIC-8, SOIC-14
NCV4279C	150 mA	5	0.5	–	250 μ A (1 mA)	\pm 2		SOIC-14
NCV4269C	150 mA	5	0.5	–	250 μ A (1 mA)	\pm 2		SOIC-8, SOIC-8 EP, SOIC-14, TSSOP-14 EP
NCV4266-2C	150 mA	3.3, 5	0.5	1	70 μ A (100 μ A)	\pm 2	✓	SOT-223
NCV4264-2C	150 mA	3.3, 5	0.5	–	70 μ A (100 μ A)	\pm 2		SOT-223
NCV8669	150 mA	5	0.6	–	50 μ A (150 mA)	\pm 2		SOIC-14
NCV8668	150 mA	3.3, 5	0.6	1	44 μ A (100 μ A)	\pm 2	✓	SOIC-8, SOIC-8 EP, SOIC-14
NCV8664C	150 mA	3.3, 5	0.6	–	30 μ A (100 μ A)	\pm 2		SOT-223, DPAK-3
NCV8660B	150 mA	3.3, 5	0.6	–	40 μ A (150 mA)	\pm 2		DPAK-5, SOIC-8
NCV8502	150 mA	Adj, 2.5, 3.3, 5, 8, 10	0.6	–	75 μ A (100 μ A)	\pm 2		SOIC-8, SOIC-16 EP
NCV8501	150 mA	Adj, 2.5, 3.3, 5, 8, 10	0.6	30	75 μ A (100 μ A)	\pm 2	✓	SOIC-8, SOIC-16 EP
NCV8508B	250 mA	3.3, 5	0.9	–	150 μ A (150 mA)	\pm 3		SOIC-8 EP, D2PAK-7
NCV8518B	250 mA	5	0.75	1	150 μ A (150 mA)	\pm 2	✓	SOIC-8 EP, SOIC-16 EP
NCV8674	350 mA	5	0.6	–	38 μ A (100 μ A)	\pm 2		D2PAK-3
NCV8675	350 mA	3.3, 5	0.6	–	50 μ A (100 μ A)	\pm 2, \pm 2.5		DPAK-5, D2PAK-5
NCV8772	350 mA	3.3, 5	0.875	1	30 μ A (350 mA)	\pm 1.5	✓	D2PAK-7, D2PAK-5, DPAK-5
NCV4274C	400 mA	3.3, 5	0.5	–	250 μ A (1 mA)	\pm 2		SOT-223, DPAK-3, D2PAK-3
NCV4276C	400 mA	Adj, 3.3, 5	0.5	10	220 μ A (1 mA)	\pm 2	✓	DPAK-4, D2PAK-5
NCV8506	400 mA	Adj, 2.5, 3.3, 5	0.6	–	150 μ A (100 μ A)	\pm 2		D2PAK-7
NCV8505	400 mA	Adj, 2.5, 3.3, 5	0.6	1	350 μ A (100 μ A)	\pm 2	✓	D2PAK-7
NCV8504	400 mA	Adj, 2.5, 3.3, 5	0.6	–	150 μ A (100 μ A)	\pm 2		SOIC-16 EP
NCV8503	400 mA	Adj, 2.5, 3.3, 5	0.6	1	350 μ A (100 μ A)	\pm 2	✓	SOIC-16 EP
NCV4275C	450 mA	3.3, 5	0.5	–	200 μ A (1 mA)	\pm 2		DPAK-5, D2PAK-5
NCV8141	500 mA	5	1.5	50	**	\pm 3	✓	D2PAK-7
NCV317M	500 mA	Adj	2.2 (Typ)	–	–	\pm 4		DPAK-3
NCV33269	800 mA	Adj, 3.3, 5, 12	1.35	–	–	\pm 2		DPAK-3
NCV317	1.5 A	Adj	2.25 (Typ)	–	–	\pm 4	✓	D2PAK-3, TO-220

** See data sheet for details.

Chipsets for Audio Power Management

The NCV8614B power management unit is optimized for power supplies - integrating LDOs, SMPSs, high side switches, buffers, and I/Os - delivering solution cost and size reductions.

The NCV8614B multiple output linear regulator with Automatic Switchover (ASO) input voltage selector is specifically designed to address automotive radio systems power supply requirements. The NCV8614B supplies power to various “always on” loads such as the CAN transceivers and microcontrollers (core, memory and I/O). The ASO circuit selects between three different input voltage sources to reduce power dissipation.

There are possible different output voltages, currents and feature configurations customized for particular applications.

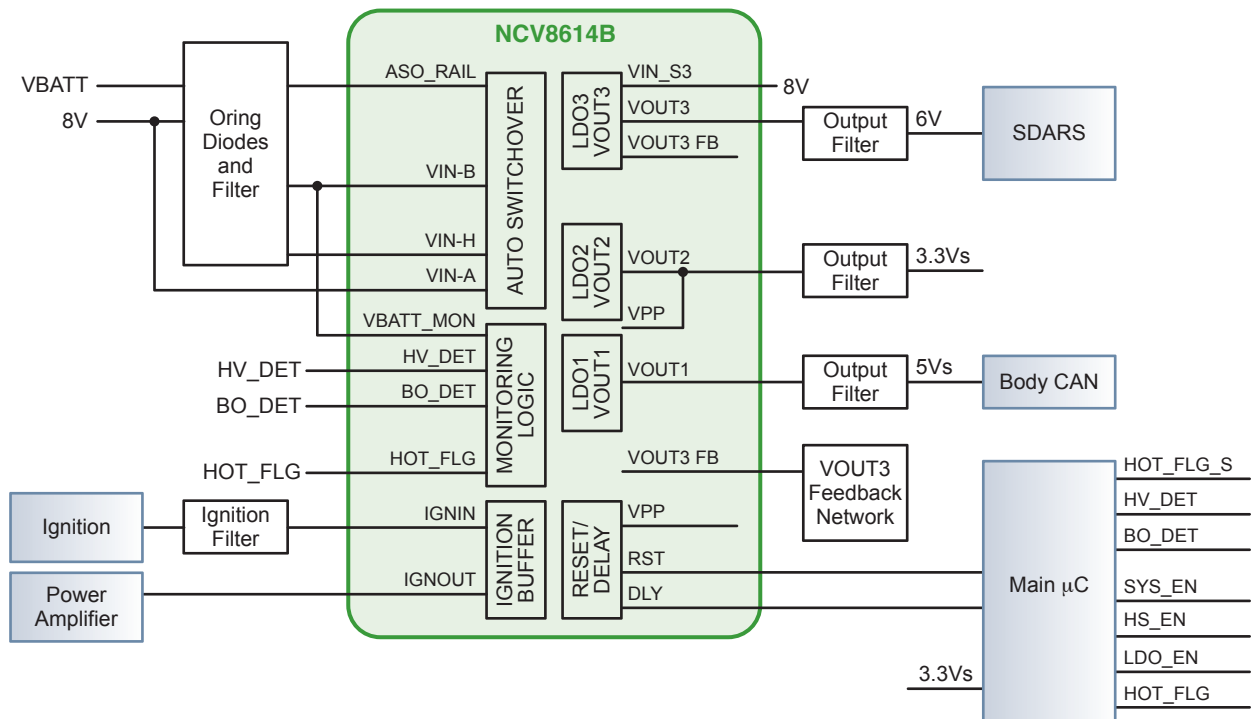

Multiple Voltage Regulators for Audio Subsystems

The LV56851UV multiple power supply for audio systems incorporates five LDOs and one high-side switch. Integrated accessory detector, battery voltage detector, and reset function reduce system parts count.

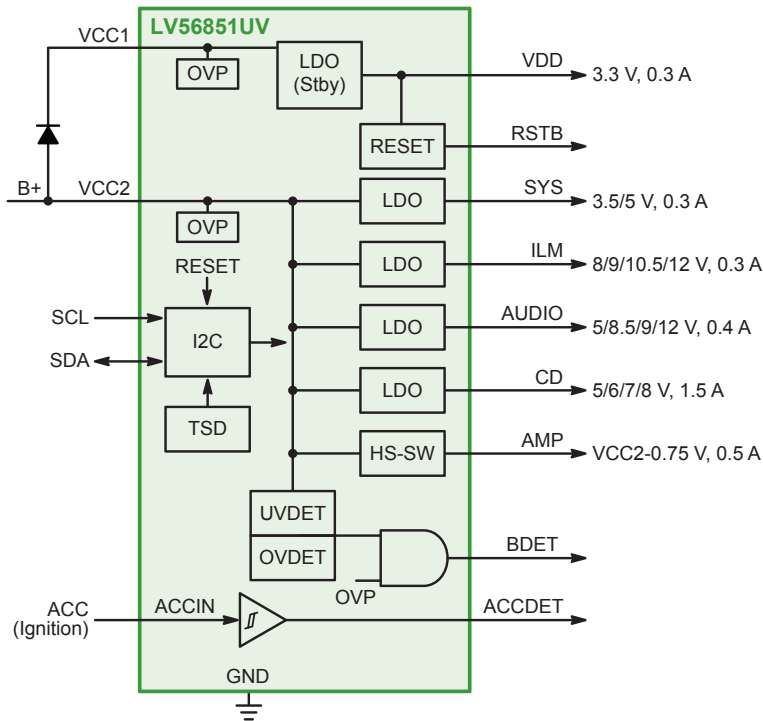

LV56851UV Features

- 5 Regulators, 1 VCC high-side switches
- Maximum surge peak voltage 50 V
- Low consumption current
- Battery voltage detector
- Accessory voltage detector
- Reset function
- Thermal warning
- Over-current, over-voltage, and over-heat protection
- I2C-bus communication interface
 - Output enable/disable
 - Detector voltage setting
 - Read back
- Low thermal resistance HZIP-15 ($\theta_{jc} = 2.5^{\circ}\text{C}/\text{W}$)

Multiple Output Power Supplies

Device	Operating Voltage (V)	I _{stby} Max (μA)	V _{stby}	REG1	REG2	REG3	REG4	REG5	REG6	High Side (mA)	Package(s)	
LV5680NPVC	10 - 16	800	5.0 V, 200 mA	8 V, 1.3 A	8-9 V (Adj), 300 mA	8-12 V (Adj), 300 mA	-	-	-	350, 300	HZIP-15J	
LV5681P			5.7 V, 200 mA	7 V, 1.3 A								
LV56801P			3.3 V, 200 mA	8 V, 1.3 A								
LV5683P		100	100	3.3/5.0 V, 300 mA	5/8 V, 1.1 A	8.5 V, 400 mA	-	3.3 V, 500 mA	-	-	-	HZIP-15
LV56831P				-	-	12 V, 500 mA	3.3/5 V, 500 mA	-	-			
LV5684NPVD				3.3 V, 350 mA	5/8 V, 1.3 A	5-12 V (Adj), 250 mA	5-12 V (Adj), 300 mA	3.3 V, 450 mA	-	-	350, 300	
LV56841PVD			-	6 V, 1.5 A	5-12 V (Adj), 300 mA	-	3.3 V, 350 mA	-	-	500, 300		
LV5685PV			3.3 V, 350 mA	5/6/7/8 V, 1.3 A	5/8.5/9/11.5 V, 250 mA	5/8/10.5/12 V, 300 mA	3.3/5 V, 450 mA	-	-	350, 300		
LV56851UV			3.3 V, 300 mA	5/6/7/8 V, 1.5 A	5/8.5/9/12 V, 400 mA	8/9/10.5/12 V, 300 mA	3.3/5 V, 300 mA	-	-	500		
LV5686PVC			5.0 V, 300 mA	-	9.0 V, 500 mA	9.85 V, 300 mA	-	-	-	300 x 2, 350 x 1, 500 x 3		
LV5692P	3.3 V, 300 mA		8 V, 1.3 A	8.4 V, 500 mA	8.4 V, 500 mA	3.3 V, 300 mA	-	Ext FET Driver	500			
LV5693P	5.7 V, 300 mA											
LV5694P	3.3/5.0 V, 300 mA		7.6/8.1 V, 2.0 A	8.45 V, 800 mA	9.0 V, 500 mA	-	5 V, 500 mA	-	500, 350			
LV5695P		8 V, 2.0 A								8.5 V, 500 mA		
LV5696P		3.3/5.0 V, 200 mA								8 V, 1.0 A	8.5 V, 300 mA	3-8 V (Adj), 200 mA

POWER MANAGEMENT

Switching Regulators and Controllers

Features

- >2 MHz Switching Frequency
- External Synchronization
- PowerGood & ENABLE
- Wide input voltage range
- Low quiescent current

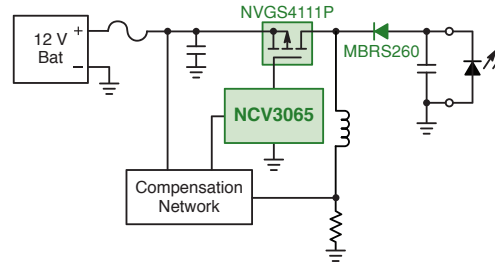

Switching Regulators

Device	I _{OUT} (A)	f _{sw} (kHz)	V _{in} Min (V)	V _{in} Max (V)	Comments	Package
NCV2574	0.5	52	4.75	40	Internal compensation	SOIC-16W
NCV2575	1.0	52	4.75	40	Internal compensation	D2PAK
NCV890100	1.2	2000	4.5	40	–	DFN-8
NCV890101	1.2	2000	4.5	40	–	DFN-10
NCV8843	1.5	Up to 700	4	40	V ²	SOIC-8, SOIC-16W, DFN-18
NCV3063	1.5	Up to 250	3	40	High f _{sw} for optimized size & efficiency	DFN-8, SOIC-8, PDIP-8
NCV3064	1.5	Up to 250	3	40	High f _{sw} for optimized size & efficiency; Enable	DFN-8, SOIC-8, PDIP-8
NCV3065	1.5	Up to 250	3	40	LED driver	DFN-8, SOIC-8, PDIP-8
NCV3066	1.5	Up to 250	3	40	LED driver with ENABLE	DFN-8, SOIC-8, PDIP-8
NCV33063	1.5	100	3	40	Buck, Boost SEPIC	SOIC-8
NCV51411	1.5	260	4.5	40	V ² , SYNC	DFN-18, SOIC-16W, SOIC-8
NCV5171	1.5	260	2.7	30	Boost, Flyback, SEPIC	SOIC-8
NCV5173	1.5	560	2.7	30	Boost, Flyback, SEPIC	SOIC-8
NCV3163	3.4	Up to 300	2.5	40	High f _{sw} for optimized size & efficiency	DFN-18, SOIC-16W
NCV33163	3.4	Up to 150	2.5	60	High input voltage	SOIC-16W, PDIP-16

Switching Controllers

Device	V _{OUT} Min (V)	f _{sw} (kHz)	V _{in} Min (V)	V _{in} Max (V)	Comments	Package
NCV494	Down to 5.0	Up to 200	7	40	Single-ended or push-pull	SOIC-16
NCV8851B	Down to 0.8	275	4.5	40	<1 μA quiescent current	SOIC-16W
NCV8852	Down to 0.8	170 to 455	3.1	44	For external P-channel MOSFET	SOIC-8
NCV8853	Down to 0.8	340	3.1	44	For external P-channel MOSFET	SOIC-8
NCV881930	3.3, 5.5	410	3.5	45	Low I _q ; low frequency	QFN-24
NCV891930	3.3, 3.65, 4.0, 5.0	2000	3.5	45	Low I _q ; high frequency	QFN-24
NCV1034	1.25	Up to 500	10	100	Synchronous Buck	SOIC-16

Audio System Solution

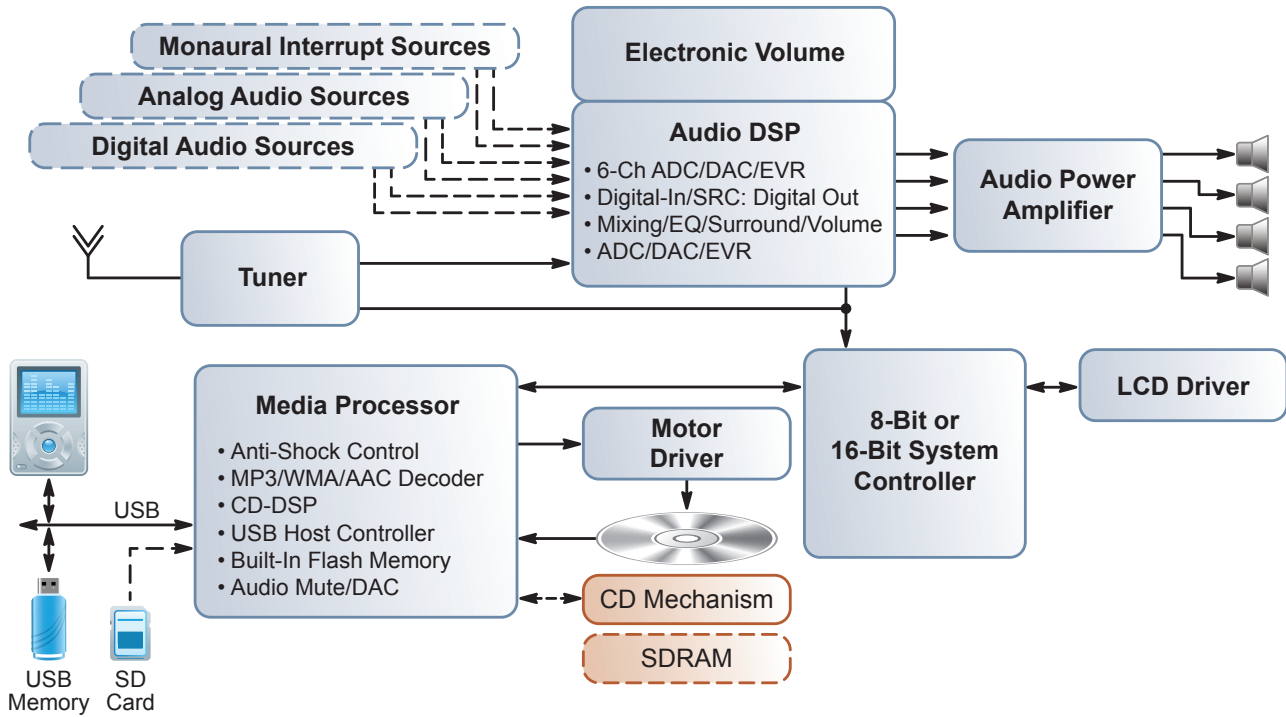

Digital Media Receiver (Mechaless) Audio System Solution

AUDIO

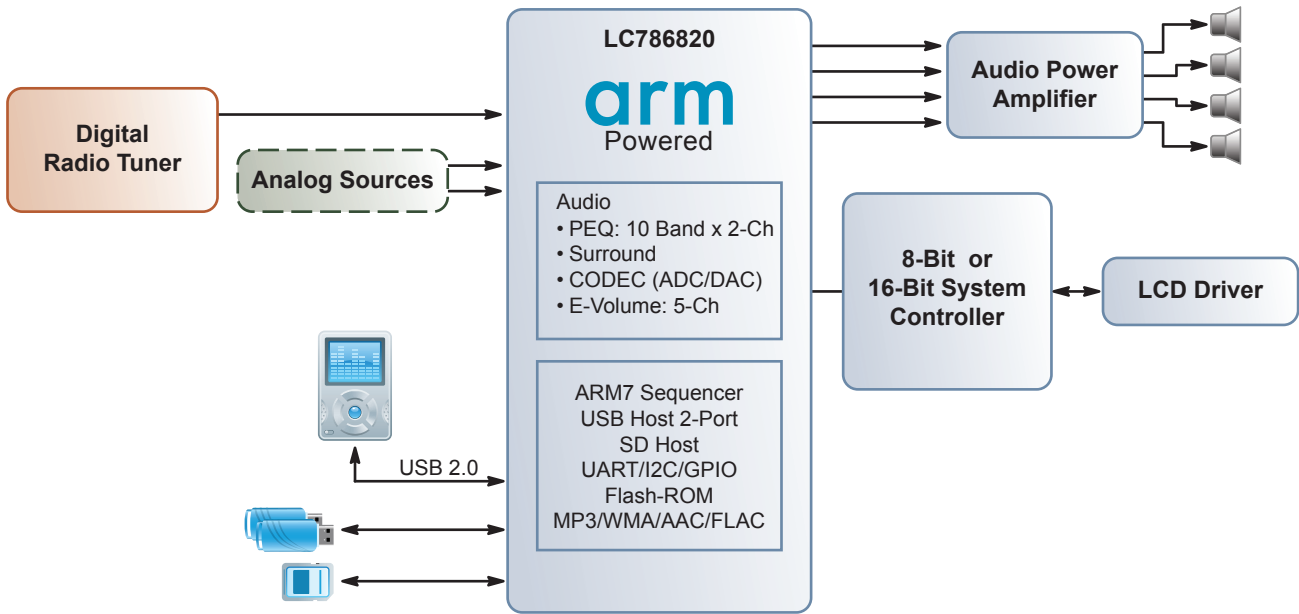

Digital Media Processor (Mechaless)

Compressed Audio Signal Processor with USB Host Controller and Bluetooth

LC786821E Features

- USB host/device function (Full speed: 12 Mbps), SD memory card host function
- MP3, WMA, AAC, FLAC, SBC decoder processing function
- Audio input: analog stereo 3-channel / digital 3-channel (sampling rate convertible)
- Audio processing: 20 band equalizer (stereo 1-channel), subwoofer processing, high-frequency range extendable filter
- Audio output: electronic volume output 5-channel (for LF, LR, RF, RR, SW), or DAC output 3-channel (Lch, Rch, SW)
- ARM7TDMI-S™ internal CPU core; flash memory for program and data storage
- Bluetooth audio processing/hands-free function

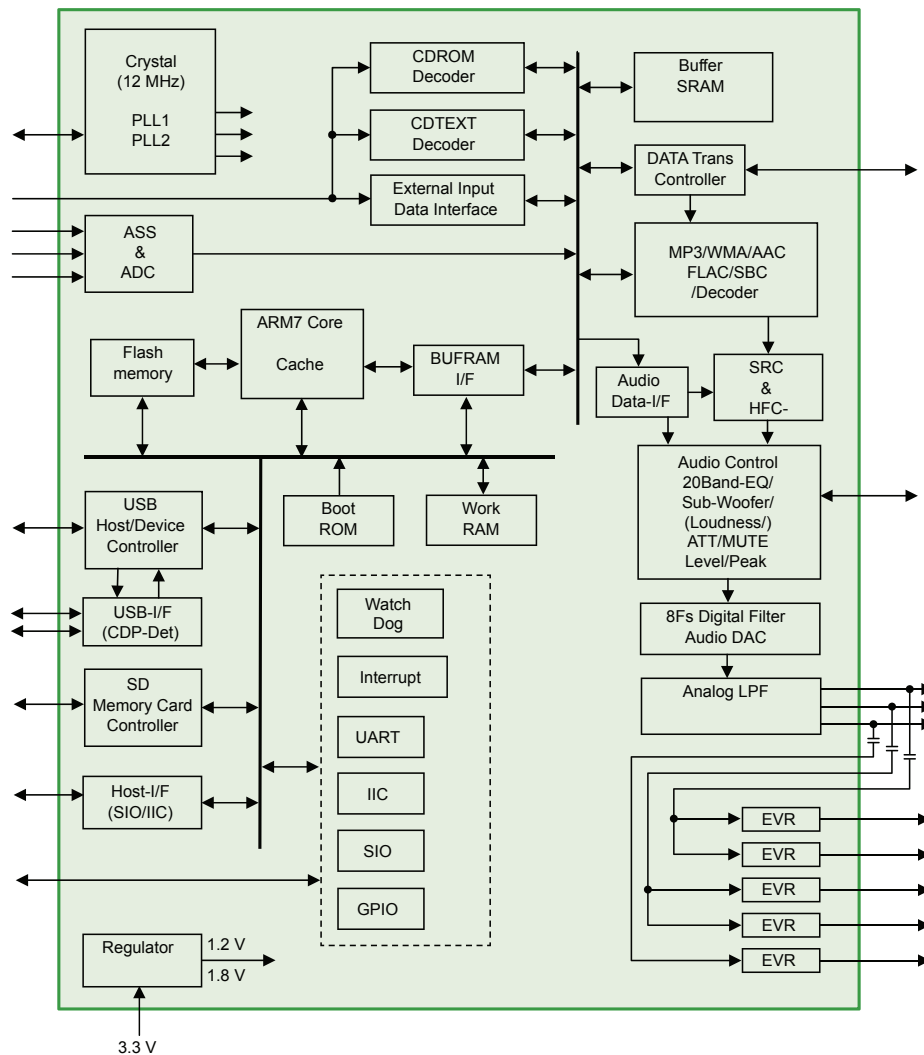

LC786821E Block Diagram

Compact Disc Controllers

LC78615E, LC78616PE Features

- RF signal processing for CD-DA/R/RW, servo control, EFM signal processing
- Outputs CDDA, CDRom data
- CD playback system realized with simple macro commands by external controller, due to internal sequencer (built in 8-bit CPU)
- Reduce audio-DAC, digital filter for reduction system cost
- LC78616PE includes shock protection with external DRAM

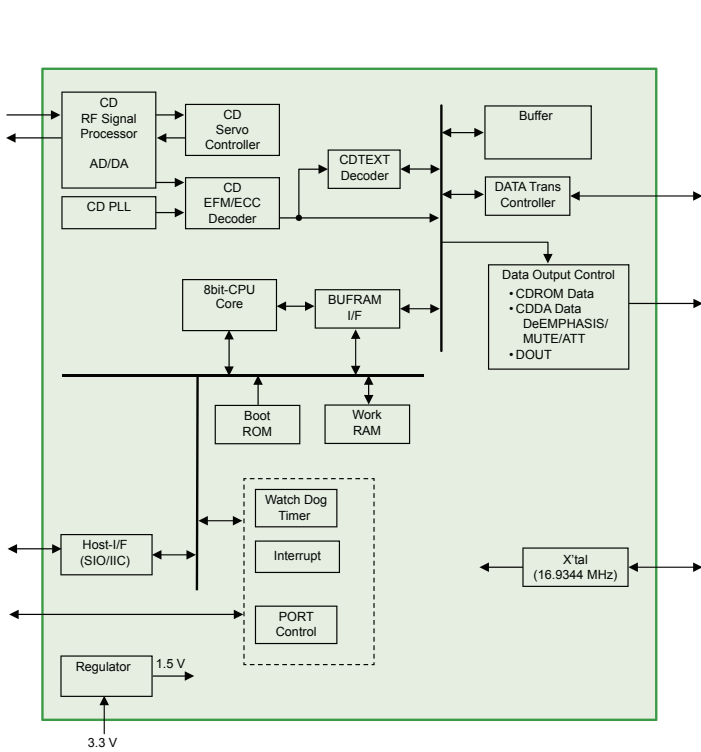

LC78615E Block Diagram
QIP-64E Package

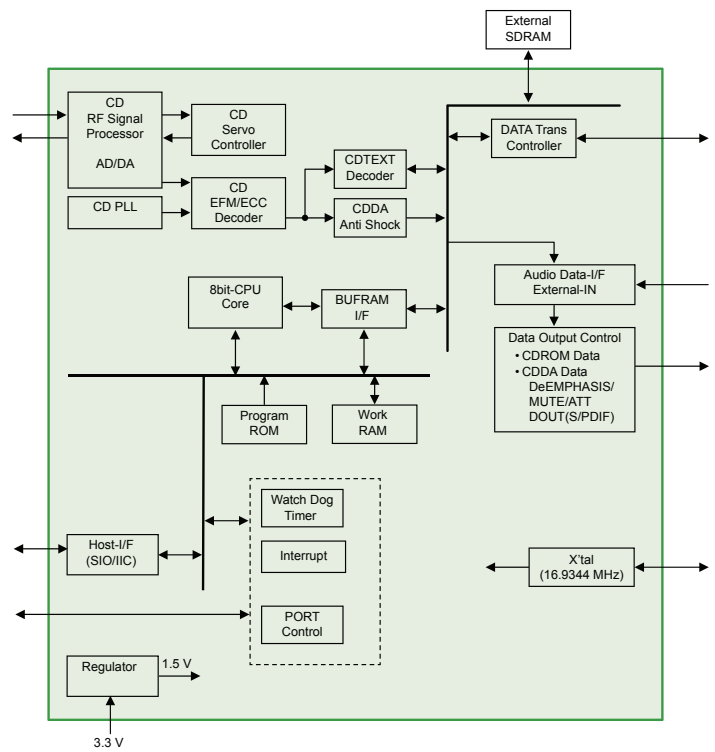

LC78616PE Block Diagram
QIP-100E Package

Decoder of DARC Standard for Car Navigation System

The LC72717 is a data demodulator and decoder for receiving FM multiplex broadcasts for mobile reception in the DARC format. LC72717 includes an on-chip band pass filter for extracting the DARC signal from the FM composite signal. The device also supports ITU-R recommended FM multiplex frame structures (methods A, A', B, and C) and enables design of a compact, multifunction DARC reception system.

LC72717 Features

- Integrates all DARC relevant functions
- Fully adjustable

Applications

- RTIC in China, Thailand and South East Asia
- DARC in Europe

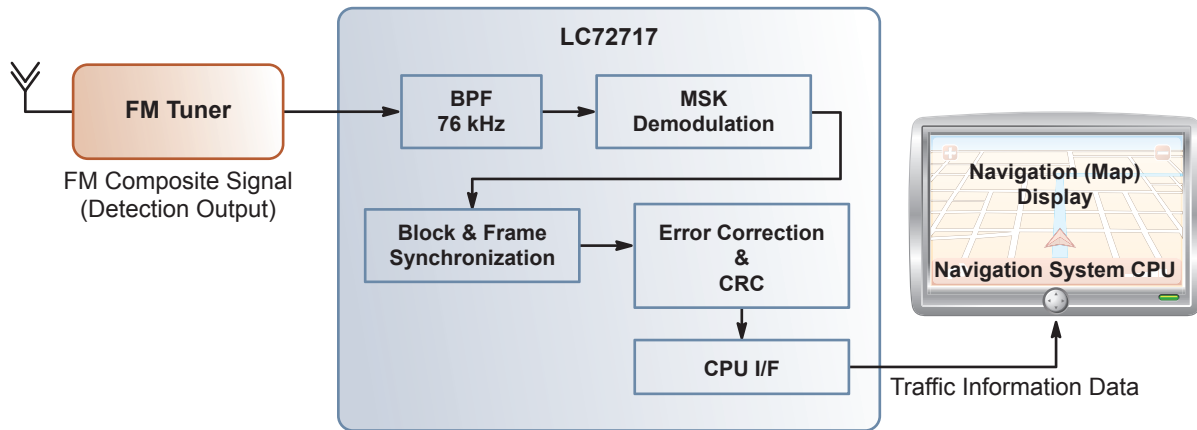

LC72717 Block Diagram

Device	Function	Application	V _{DD} (V)	Packages
LC72717	DARC Decoder	RTIC (China)	2.7 to 3.6	SQFP-64

Data Demodulation for Navigation Systems

The LC727103UJ* is a data demodulation device for receiving FM multiplex broadcasts for mobile reception in the DARC format. LC727103UJ includes VICS WIDE decoders** for new SI and a VICS data input-output interface for external VICS data. The device also includes an on-chip band-pass filter for extracting the DARC signal from the FM baseband signal, and can implement a compact, multifunction VICS reception system.

LC727103UJ Features

- DARC signal reception
- Error correction function based on 2T delay in MSK detection stage
- On-chip 76 KHz band-pass filter
- MSK demodulation
- Block and Frame synchronization
- Error correction using (272,190) product code
- On-chip Frame memory and memory control circuit for vertical error correction of product code

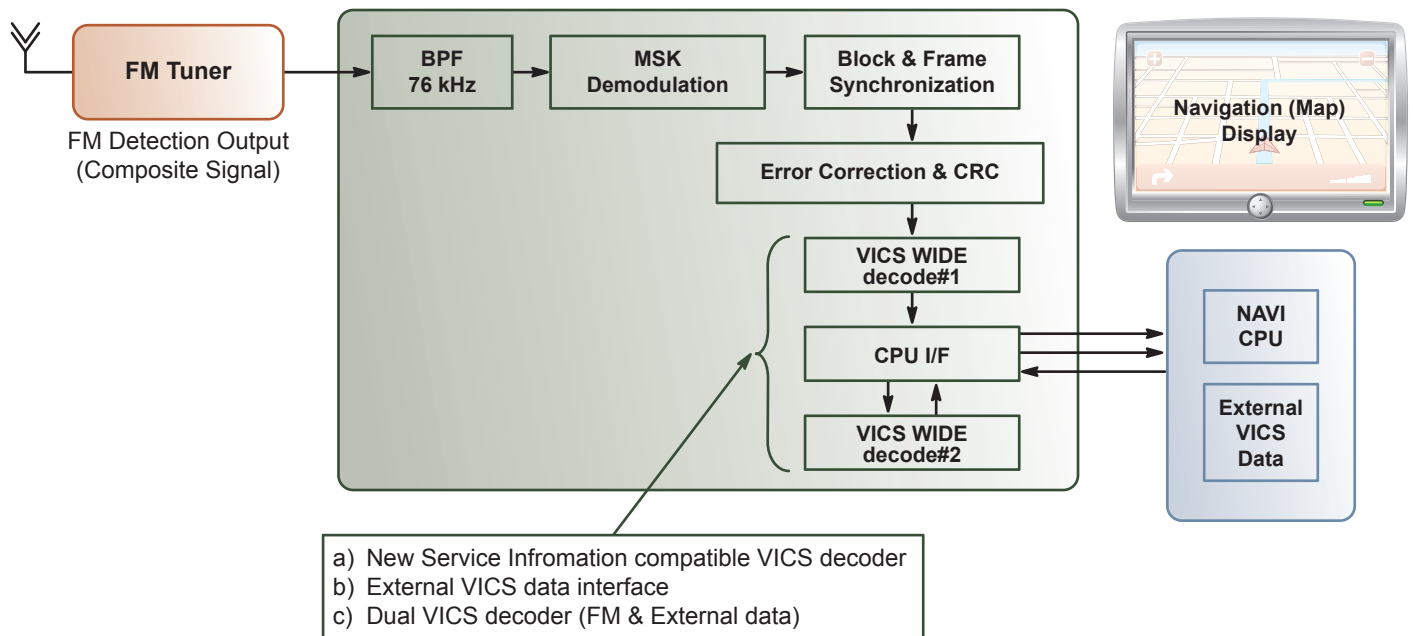

LC727103UJ Block Diagram

* Pending 4Q18. ** VICS Center License required.

Demodulator for RDS and RBDS Standards

LC72725 Features

- RDS demodulation, 57 kHz carrier and data clock regeneration, bi-phase decode, differential decode
- RDS-ID detect signal with reset
- Switched capacitor bandpass filter
- 128-bit on-chip data buffer
- Standby control

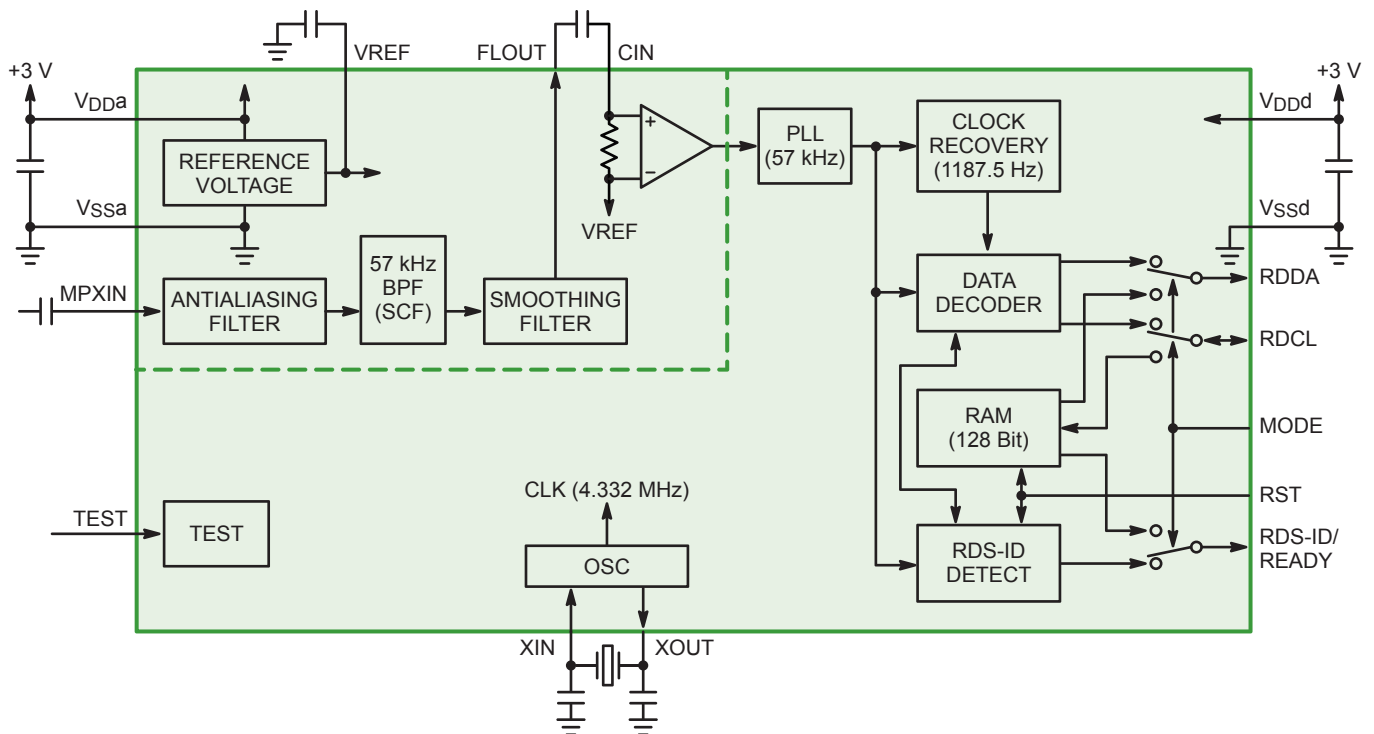

LC72725 Block Diagram

Protection for USB 2.0

One High Speed Pair, V_{CC} , Low Capacitance ESD, Short-to-Battery (STB) and Short-to-Ground (STG) Protection

Key Requirement

- Capacitance < 1.5 pF for data lines

Features

- Capacitance 0.4 - 1.0 pF for data lines
- 4 low speed + 1 VBUS integrated – can protect up to 2 USB ports
- Industry leading low capacitance and clamping voltage with STB capability
- LVDS compatible

Device	V_{BR} Min (V)	Lines	Capacitance (pF)	Protection Scheme	Package
SZESDM3551	5.6	1	21	VBUS ESD + Surge	X2DFN-2 (SOD-882)
SZESD7205	5.2	2	0.55 0.85	ESD	SOT-723, SC-70 (SOT-323)
SZESD7102	16.5	2	0.40	ESD + STB Standoff	SC-75
NIV1161	16.5	2	0.65	ESD + STB Limiting	WDFN-6
NIV2161	16.5	2	0.65	ESD + STB & STG Limiting	WDFN-10
SZNUP2114	5.5	3	1.00	ESD	TSOP-6, SOT-553

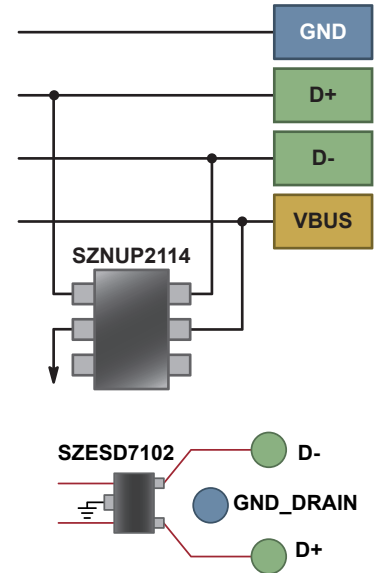

One High Speed Pair, V_{CC} , Common Mode Filter + ESD Protection

Key Requirement

- Capacitance < 1.5 pF for data lines
- Common Mode Filtering

Features

- Capacitance 0.9 pF for data lines
- Integrated EMI suppression with ESD protection
- Industry leading low clamping voltage

Device	Pairs	Capacitance @ 2.5 V (pF)	CM Attenuation @ 750 MHz (-dB)	DM Bandwidth F3dB (GHz)	Package
SZEMI2121	1	0.9	-35	2.5	WDFN-8

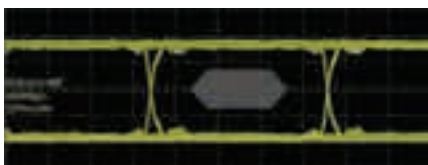
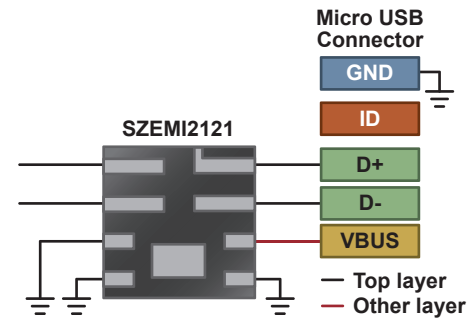
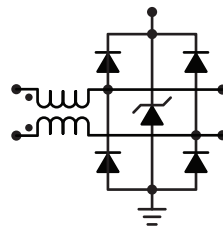

USB 2.0 @ 480 Mb/s

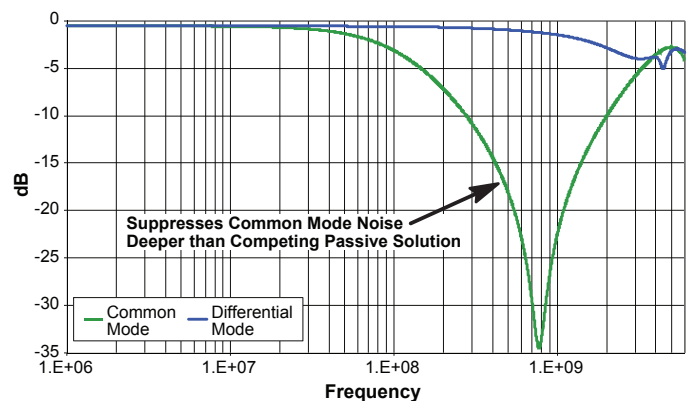

PROTECTION

Enhance Reliability of Electronic Modules with ESD Protection Devices

I/O & Sensor Protection

Device	Diode Configuration	VBR Range	Ppk ¹	ESD Rating	C _j	Package
SZMM5Z Series	Single Unidirectional	4.0 to 15 V	175 W	>30 kV ²	<150 pF	SOD-523
SZMM3Z Series	Single Unidirectional	2.4 to 75 V	–	>16 kV ³	<300 pF	SOD-323
SZMMSZ Series	Single Unidirectional	1.8 to 110V	–	>16 kV ³	<300 pF	SOD-123
SZMMSZ E Series	Energy Rated Single	1.8 to 110V	225 W	>16 kV ³	<300 pF	SOD-123
SZMMBZ Series	Single Unidirectional	2.4 to 91 V	–	>16 kV ³	<300 pF	SOT-23
SZMMBZ E Series	Energy Rated Single	2.4V to 91 V	225 W	>16 kV ³	<300 pF	SOT-23
SZMMBZ A Series	Dual Common Anode	5.6 to 33 V	–	>16 kV ³	<300 pF	SOT-23
SZBZX84 Series*	Single Unidirectional	2.4 to 75 V	–	>16 kV ³	<450 pF	SOT-23
SZBZX84 E Series	Energy Rated Single	2.4 to 75 V	225 W	>16 kV ³	<450pF	SOT-23
SZMZ8F Series*	Single Unidirectional	2.4 to 47 V	–	>16 kV ³	<210 pF	X2DFNW2 (SOD-882)
SZMZ9F Series*	Single Unidirectional	2.4 to 24 V	–	>16 kV ³	<210 pF	SOD-923
SZESD7272**	Unidirectional	27 V	–	>15 kV ²	<1 pF	SOT-23

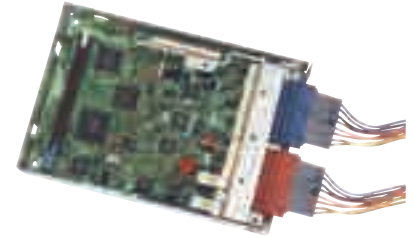

1. 8/20 μs surge waveform. 2. IEC 61000-4-2 contact discharge. 3. Human body model. * 2% and 5% tolerance available. ** MLCC Capacitor Replacement.

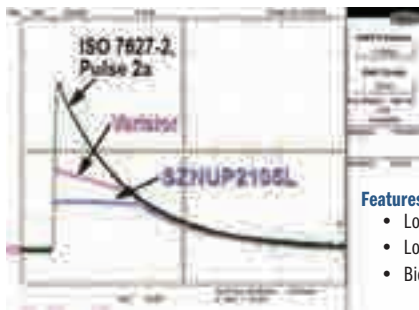
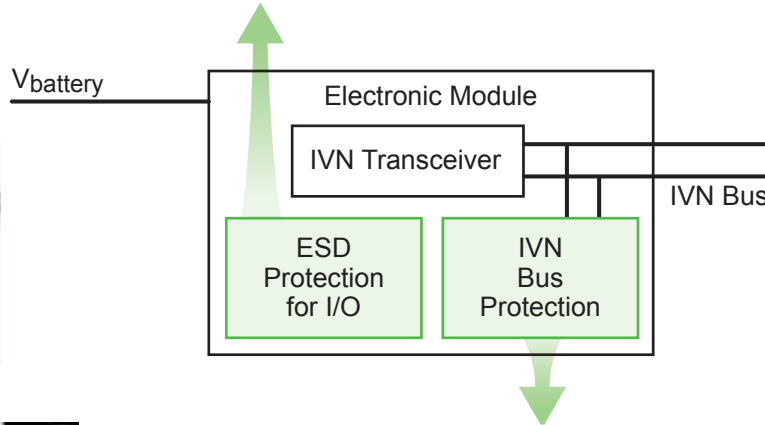

Features

- Low Clamping Voltage
- Low Capacitance
- Bidirectional Clamping

In-Vehicle Networking Protection

Device	Network	Diode Configuration	VBR Min (V)	Vclamp Max (V)	Ipp (A)	Capacitance Max (pF)	Package
SZNUP2115	FlexRay	Dual Bi-Directional	26.2	50	3	10	SOT-23
SZNUP2105	CAN	Dual Bi-Directional	26.2	44	8	30	SOT-23
SZNUP3105	CAN	Dual Bi-Directional	35.6	66	8	30	SOT-23
SZNUP3125	CAN	Dual Bi-Directional	35.6	65	3	10	SC-70 (SOT-323)
SESDONCAN1	CAN-FD	Dual Bi-Directional	26.2	50	3	10	SOT-23
SZNUP2125	CAN-FD	Dual Bi-Directional	26.2	50	3	10	SC-70 (SOT-323)
SZNUP2128	CAN	Dual Bi-Directional	28.0	70	3	15	SC-70 (SOT-323)
SZNUP1128*	LIN	Single Bi-Directional	28.0	70	3	15	SOD-323
SZESD1L001	Ethernet	Quad Uni-Directional	16.5	–	–	1	SC-88 (SOT-363)
SZESD7205	Ethernet	Dual Uni-Directional	5.2	–	–	0.55 0.85	SOT-723 SC-70 (SOT-323)

* Pending 4Q18.

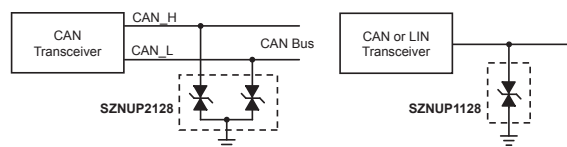

CAN and LIN protection devices improve the noise immunity and reliability of vehicular networks by suppressing overvoltage transients from conducted and radiated EMI and ESD.

PROTECTION

Silicon Carbide Diodes

Features

- High power density, efficiency, and reliability
- High surge and avalanche capability
- Low system losses via no reverse Q_{rr} recovery, no forward recovery, and low V_f
- Minimized reverse recovery charge (Q_{rr}) reduces switching losses & enables high speed switching
- Stable temperature characteristics enable high-temperature operation without increasing switching losses
- High temperature operation and life time for automotive applications

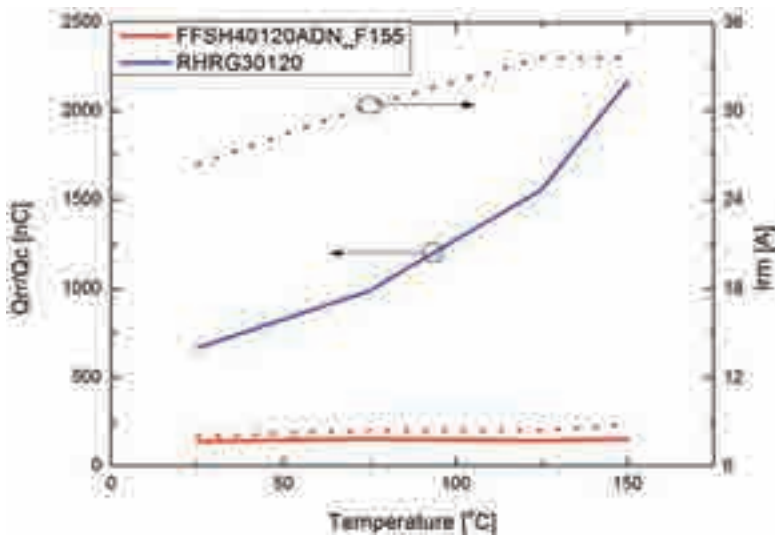

Reverse Recovery & Leakage vs Temperature

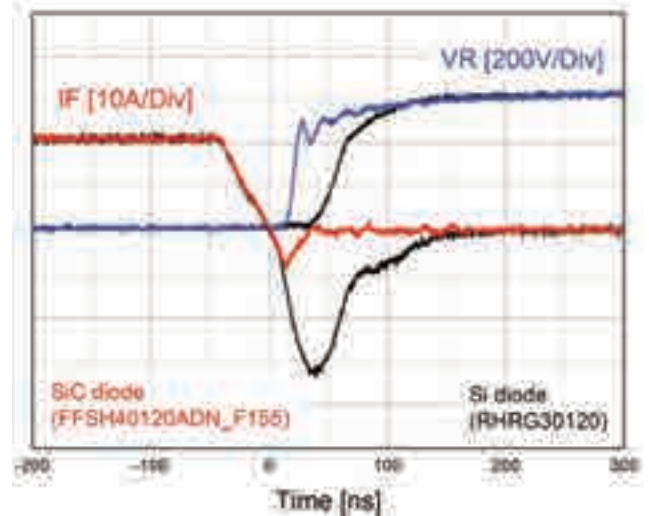

Reverse Recovery @ 20 A, 500 A/ μ s, 125°C

Device	V_{RRM} (V)	V_f Max (V)	Continuous Forward Current (A)	Package
FFSB1065B-F085*	650	1.7	10	D2PAK
FFSD1065B-F085	650	1.7	10	DPAK-3
FFSH2065BDN-F085	650	1.7	20	TO-247-3L
FFSH3065B-F085	650	1.7	30	TO-247-2L
FFSB3065B-F085	650	1.7	30	D2PAK
FFSB10120A-F085*	1200	1.74	10	D2PAK
FFSH10120A-F085	1200	1.74	10	TO-247-2L
FFSH20120ADN-F085	1200	1.74	20	TO-247-3L
FFSB20120A-F085*	1200	1.74	20	D2PAK
FFSH20120A-F085	1200	1.74	20	TO-247-2L
FFSH40120ADN-F085	1200	1.74	40	TO-247-3L

* Pending 4Q18.

Wide Selection of Automotive Grade Small Signal Discretes

ON Semiconductor offers a wide range of devices that support infotainment systems, including diodes, JFETs, bipolar transistors, digital transistors (BRTs), and application specification discrete integration. Within these different technologies, the company offers a range of large to small packaging, meeting the smaller board space requirements of space constrained environments.

Device	Voltage Range	Current Range	Key Features	Functions	Package(s)
Schottky Diodes	7 - 70 V	20 mA - 1 A	Low Vf, Low Leakage, Duals	DC-DC converters, high-speed switching, Oring/rectifying	SOD-123, SOD-323, SOT-23, SC-70, SC-75, SOD-523, SOD-723
Switching Diodes	35 - 350 V	-	Switching speed, Low leakage	Broad range of applications	SC-59, SOT-23, SC-70, SC-88 6, SC-88A-5, SOT-563, SC-75, SOD-123, SOD-323, SOD-523
Low V _{CE(sat)} Transistors	12 - 100 V	700 mA - 6 A	Ultra-low V _{CE(sat)} Broad portfolio	Battery charging circuit, switching, fan control	DPAK, SOT-223, TSOP-6, ChipFET, SOT-23, SOIC-8, WDFN*
JFETs	25 - 30 V	20 - 150 mA	Interchangeable Drain and Source, high input resistance	Ideal for applications sensitive to noise	SOT-23
Darlington Transistors	30 - 350 V	300 mA - 10 A	High HFE	-	D2PAK, DPAK, SOT-23
Audio Transistors	50 - 350 V	2 - 8 A	Linear gain Excellent SOA	High power audio amplifiers	DPAK
Bipolar Power Transistors	45 - 450 V	500 mA - 60 A	Low leakage Low saturation	Lamp ballast	SC-89, SOT-223, DPAK, D2PAK, SOT-23, SOT-723, WDFN, SOT-563
General Purpose Transistors	7 - 300 V	50 mA - 10 A	Broad product range	Broad range of applications	Multiple surface mount packages available
Digital Transistors (BRTs)	15 - 50 V	100 mA - 3 A	Broad Portfolio of R1 and R2 combinations	Power switching	SC-59, SOT-23, SC-70, SC-88-5, SC-88A-6, SOT-563

* With wettable flanks.

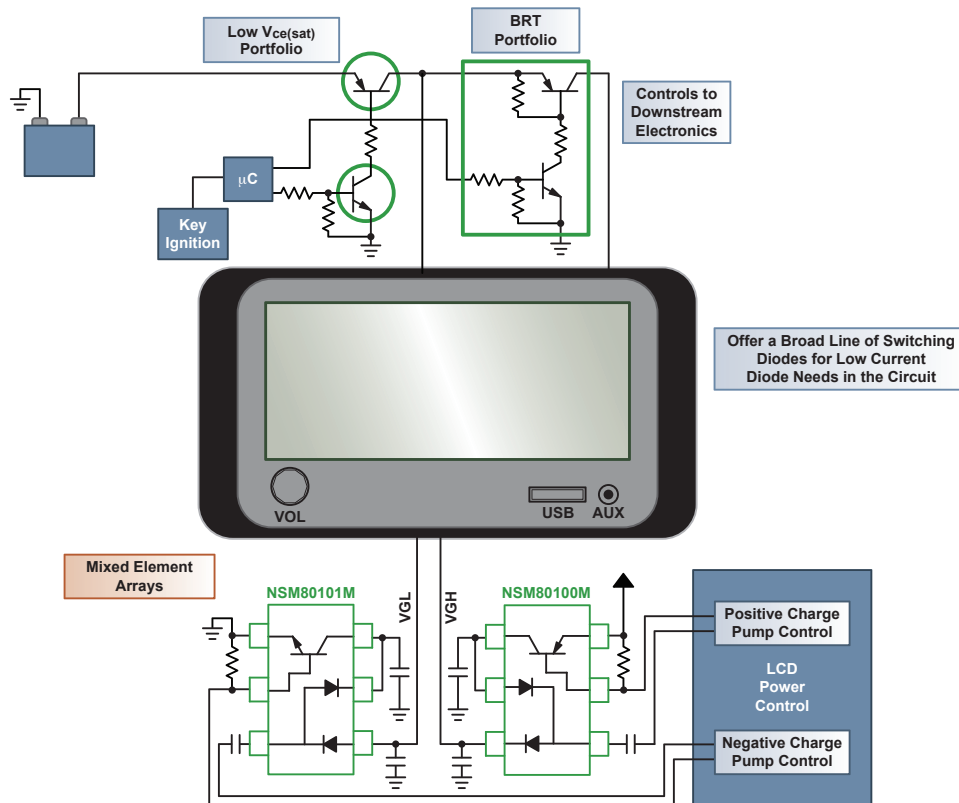

COMPONENTS

Discrete Components for Antennas

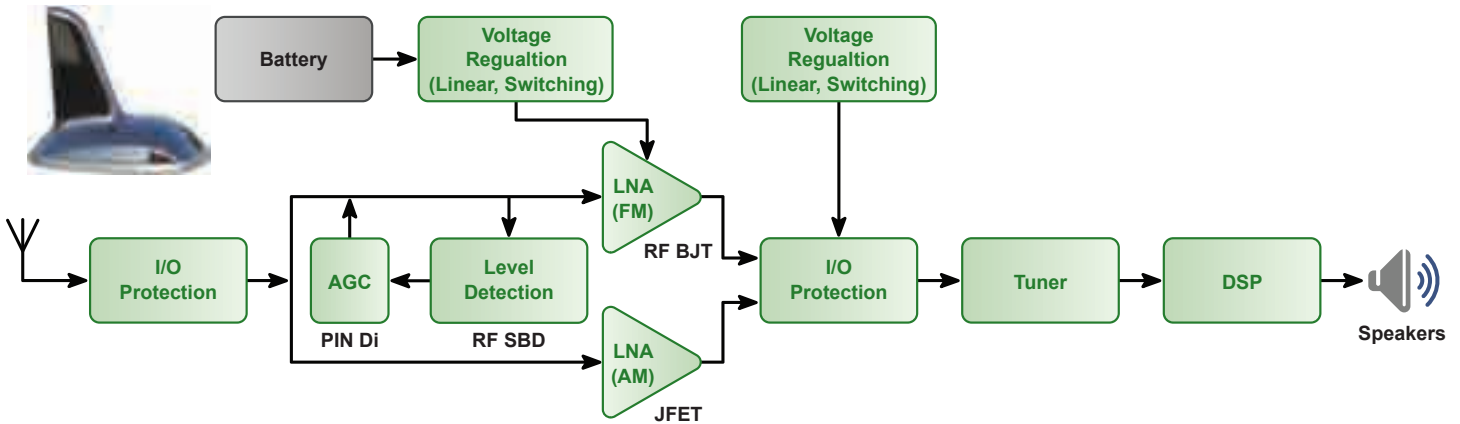

JFET Features

- Large forward transfer admittance and low noise figure enhance receiver sensitivity
- High ESD immunity
- High V_{GDS} for robust circuit design
- Low capacitance improves receiver sensitivity
- High power density

JFETs

Device	Configuration	V_{GDS} (V)	I_{DSS} (mA)	V_{GSoff} (V)	g_m (mS)	C_{iss} (pF)	Package(s)
NSVJ2394SA3	Single	15	10-32	-1.5 to -0.3	38	10	SC-59
NSVJ3557SA3	Single	15	10-32	-1.5 to -0.3	35	10	SC-59
NSVJ3910SB3	Single	25	20-40	-1.8 to -0.6	40	6	SOT-346 (CPH-3)
NSVJ5908DSG5	Dual	15	10-32	-1.5 to -0.3	35	10	MCPH-5
NSVJ6904DSB6	Dual	25	20-40	-1.8 to -0.6	40	6	SOT-26 (CPH-6)

RF Transistors

Device	Max Ratings		f_T Typ (GHz)	Package(s)
	V_{CE} (V)	I_C (mA)		
NSVF6003SB6	12	150	7 @ $V_{CE} = 5$ V, $I_C = 50$ mA	SOT-26 (CPH-6)
NSVF6001SB6*	12	100	6.7 @ $V_{CE} = 5$ V, $I_C = 30$ mA	SOT-26 (CPH-6)
NSVF4015SG4	12	100	10 @ $V_{CE} = 3$ V, $I_C = 30$ mA	SOT-343 (MCPH-4)
NSVF4017SG4	12	100	10 @ $V_{CE} = 3$ V, $I_C = 30$ mA	SOT-343 (MCPH-4)
NSVF3007SG3	12	30	8 @ $V_{CE} = 5$ V, $I_C = 10$ mA	SOT-323 (MCPH-3)
NSVF5501SK	10	70	5.5 @ $V_{CE} = 5$ V, $I_C = 20$ mA	SC-81 (SSFP)
NSVF4020SG4	8	150	16.5 @ $V_{CE} = 5$ V, $I_C = 50$ mA	SOT-343 (MCPH-4)
NSVF4009SG4	3.5	40	25 @ $V_{CE} = 3$ V, $I_C = 20$ mA	SOT-343 (MCPH-4)

* Pending 4Q18.

Pin Diode Features

- Series connection of two elements in small package
- Low inter-terminal capacitance

PIN Diodes

Device	V_R (V)	I_F (mA)	C Typ ¹ (pF)	r_s Typ ² (Ω)	Package(s)
NSVP249SDSF3	50	50	0.23	4.5	SOT-323 (MCP)
NSVP264SDSA3*	50	50	0.23	2.5	SOT-323 (MCP)

* Pending 4Q18. 1. C Typ @ $V_R = 50$ V, $f = 1$ MHz. 2. r_s Typ @ $I_F = 10$ mA, $f = 100$ MHz.

RF Transistor Features

- High gain and low noise for receiver sensitivity
- Low distortion input
- High power capability for use in high temperature applications

RF Schottky Barrier Diode Features

- Low forward voltage
- Low inter-terminal capacitance

Schottky Barrier Diodes

Device	V_R (V)	V_F ¹ (mV)	C Typ ² (pF)	Package(s)
NSVR201MX	2	320	0.15	X2DFN-2
NSVR351SDSA3	5	230	0.69	SOT-346 (CP)

1. V_F @ $I_F = 1$ mA. 2. C Typ @ $V_R = 50$ V, $f = 1$ MHz.

Wide Selection of Automotive Grade Power MOSFETs

ON Semiconductor offers an expansive portfolio of Power MOSFETs, utilizing advanced Trench and SuperFET® Technology. Devices enable increased system level efficiency through low switching losses and low conduction losses, and are available in a range of standard and innovative packages.



TO-247

SO-8 FL

TO-Leadless

μ8FL

TO-220

Low to Medium Voltage

- 20 V to 200 V, Standard Gate & Logic Level
- N & P Channel, Singles & Duals
- Wide $R_{DS(on)}$ range from 0.5 mΩ for 40 V in 5 x 6 mm package, to 7.5 Ω general purpose switches
- Planar & multiple Trench technologies
- Package types including:
 - Small footprint – SOT-23, SC-70/75/88, SSOT-3/6, TSSOP-6, SO-8
 - Traditional – DPAK, D2PAK, TO-220, SOT-223
 - Surface Mount – μ8FL, SO-8 FL, Power88, TO-Leadless
 - With Dual Cool, & DFN being introduced

High Voltage Fast Switching

- 600 V to 650 V, N Channel, Standard Gate Level
- 650 V SuperFET II – Typical $R_{DS(on)}$ of 41 - 190 mΩ
- 650 V MOSFET KGD Dies SuperFET I and II – Typical $R_{DS(on)}$ of 41, 77, and 190 mΩ
- New SuperFET III technology in development with typical $R_{DS(on)}$ of 23 - 70 mΩ
- Lowest $R_{DS(on)}$ for the Automotive Qualified Super junction HV MOSFET's in different thru hole packages – TO-247-3L and TO-220
- MOSFET Modules in development
 - High thermal performance
 - Enhanced EMI, isolation, and current capabilities
 - System level cost reduction
 - Enable compact system solution with proven reliability
- One of best-in-class Figure of Merit ($Q_g^* R_{DS(on)}$) for automotive qualified MOSFETs

IGBT Gate Drivers for High Voltage and High Power Applications

Features

- High current output (+4 A/-6 A) at Miller Plateau for higher system efficiency
- Short propagation delays with accurate matching for improved system reliability
- UVLO, DESAT, Miller Clamp, Negative VEE for system protection
- 5 V reference for external logic
- AEC-Q100 Qualified

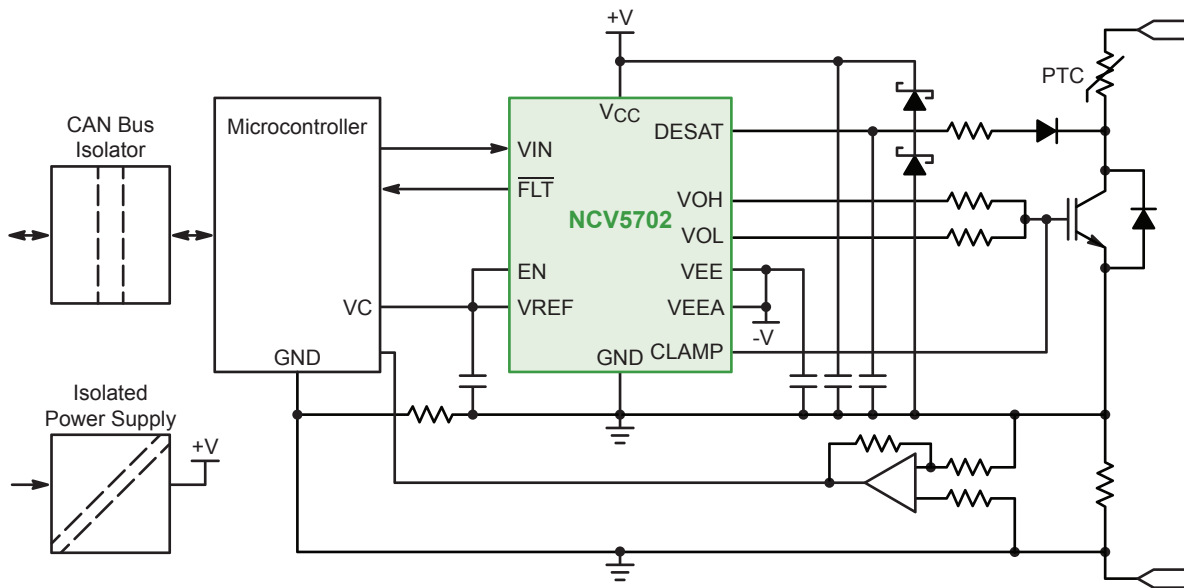

PTC Heater Application Schematic

Device	Features + Options	Inverted Output	Fault Output	V _{IN} Max (V)	V _{CC} Max (V)	Drive Source/Sink Typ (A)	Rise/Fall Time (ns)	t _{pd} Max (ns)	Package
NCV5700	DESAT + CLAMP + VEE + VOH/VOL	Yes	Active Low	5.5	35	4/6	30/30	75	SOIC-16
NCV5701A	DESAT + CLAMP	Yes	Active Low	5.5	35	4/6	30/30	75	SOIC-8
NCV5701B	DESAT + VEE	Yes	Active Low	5.5	35	4/6	30/30	75	SOIC-8
NCV5701C	DESAT + VOH/VOL	Yes	Active Low	5.5	35	4/6	30/30	75	SOIC-8
NCV5702	DESAT + CLAMP + VEE + VOH/VOL	No	Open Drain	5.5	35	4/6	30/30	75	SOIC-16
NCV5703A	DESAT + CLAMP	No	Open Drain	5.5	35	4/6	30/30	75	SOIC-8
NCV5703B	DESAT + VEE	No	Open Drain	5.5	35	4/6	30/30	75	SOIC-8
NCV5703C	DESAT + VOH/VOL	No	Open Drain	5.5	35	4/6	30/30	75	SOIC-8

MOSFET & IGBT Gate Drivers for ICE, EV/HEV, and 48 V

Features

- Large sink and source current capability
- Fast drivers with short propagation delay
- SOIC-14 and SOIC-16 packages for applications with HV clearance requirements
- Separate power and signal ground for higher immunity against high di/dt
- Various protection features such as UVLO and shoot-through prevention
- Custom options

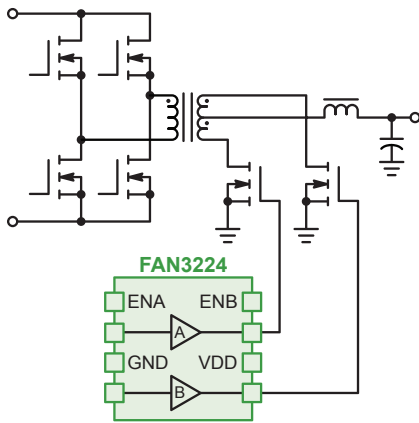

Synchronous Rectification Application

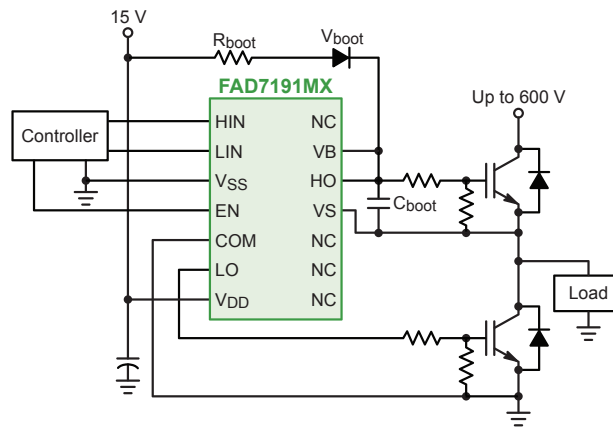

Motor Drive Application

Device	Description	Sink/Source Output Current	Undervoltage Lockout	Peak Transient (V)	Shoot Through Prevention	Enable/ Shut Down Pin	Input level	Inverted Output	Package(s)
FAN3229 (F085)	Dual Low Side Gate Driver	1.6/2.4 A	✓	20			CMOS/TTL**		SOIC-8
FAN3121 (F085)	Single Low Side Gate Driver	7.1/9.7 A	✓	20		✓	CMOS/TTL	✓	SOIC-8
FAN3122 (F085)	Single Low Side Gate Driver	7.1/9.7 A	✓	20		✓	CMOS/TTL		SOIC-8
FAN3213 (F085)	Dual Low Side Gate Driver	2.8/4.3 A	✓	20			TTL	✓	SOIC-8
FAN3214 (F085)	Dual Low Side Gate Driver	2.8/4.3 A	✓	20			TTL		SOIC-8
FAN3216 (F085)	Dual Low Side Gate Driver	1.6/2.4 A	✓	20			TTL	✓	SOIC-8
FAN3217 (F085)	Dual Low Side Gate Driver	1.6/2.4 A	✓	20			TTL		SOIC-8
FAN3223 (F085)	Dual Low Side Gate Driver	2.8/4.3 A	✓	20		✓	CMOS/TTL	✓	SOIC-8
FAN3224 (F085)	Dual Low Side Gate Driver	2.8/4.3 A	✓	20		✓	CMOS/TTL		SOIC-8
FAN3225 (F085)	Dual Low Side Gate Driver	2.8/4.3 A	✓	20			CMOS/TTL**		SOIC-8
FAN3226 (F085)	Dual Low Side Gate Driver	1.6/2.4 A	✓	20		✓	CMOS/TTL	✓	SOIC-8
FAN3227 (F085)	Dual Low Side Gate Driver	1.6/2.4 A	✓	20		✓	CMOS/TTL		SOIC-8
FAN3228 (F085)	Dual Low Side Gate Driver	1.6/2.4 A	✓	20			CMOS/TTL**		SOIC-8
FAN1100 (F085)	Ignition IGBT Driver	-		28			1.2 V VINL / 2 V VINH		SOIC-8
NCV51705*	Low side SiC Driver	6/6 A	Adjustable	28	✓	✓	TTL	✓	QFN-24
NCV51511	High Frequency, High Side and Low Side Gate Driver with Bootstrap Diode	3/6 A		100			TTL		SOIC-8 EP
FAN7085 (F085)	High Side Gate Driver with Cboot Recharge Path	450/450 mA	✓	300		✓	CMOS		SOIC-8
NCV5183	High and Low Side Gate Driver	4.3/4.3 A	✓	600			3.3 & 5 V Logic Compatible		SOIC-8
NCV5106A	High and Low Side Gate Driver	250/500 mA	✓	600			3.3 & 5 V Logic Compatible		SOIC-8
FAN7080 (F085)	Half Bridge Gate Driver	300/600 mA	✓	600	✓	✓	3.3 / 5 V logic compatible		SOIC-8
FAN7081 (F085)	High Side Gate Driver	250/500 mA	✓	600			CMOS		SOIC-8
FAN7083 (F085)	High Side Gate Driver	200/400 mA	✓	600		✓	CMOS		SOIC-8
NCV5104	Single Input High and Low Side Gate Driver	250/500 mA	✓	600	✓	✓	3.3 & 5 V Logic Compatible		SOIC-8
FAN7171 (F085)	High Side Gate Driver	4/4 A	✓	600			3.3 / 5 V logic compatible		SOIC-8
FAN7191 (F085)	High Side and Low Side High Gate Driver	4.5/4.5 A	✓	600			3.3 / 5 V logic compatible		SOIC-8
FAD7191M1X	High Side and Low Side Gate Driver with Separate Grounds	4.5/4.5 A	✓	600		✓	3.3 / 5 V logic compatible		SOIC-14
FAD8253MX*	Half Bridge Gate Driver with Separate Grounds	2/2.5 A	✓	1200	✓	✓	3.3 / 5 V logic compatible		SOIC-14

* Pending Q018. ** Differential input.

Smart Drivers & Bridges

In automotive systems, there are many different kind of actuators, including relays, bulbs, LEDs, motors, and other resistive and inductive loads. The variety of motor applications in modern vehicles is huge and is growing dramatically due to the increased demand for more efficiency. Comfort electronics – such as electrical window lifts, central door locks, and climate control systems – continue to increase automotive electronic content. The easiest to implement, DC brush motors are the most common electric motors used today. To reduce noise and to increase reliability, stepper motors are becoming more popular in position control applications, e.g. HVAC flaps.

ON Semiconductor provides drivers with integrated power stages; in addition, the company offers pre-drivers that control external MOSFETs in applications where the high load current makes MOSFET integration impractical.

Product types in portfolio:

- Pre-Driver
- Multi-channel pre-driver
- Motor control pre-driver
- Multi-channel integrated driver
- Multiple single-ended high-side and low-side driver
- Configurable high-side and low-side driver
- Half-bridge driver
- High current integrated H-bridge driver
- Stepper motor driver

Pre-Drivers

Device	Description	SPI	Direct Control	Load Current	3.3 V / 5 V	V _s Max	Diagnostics		Package
							OL/UL	SC	
NCV7513B	Hex LS Pre-Driver	16-bit	✓	external MOSFET	✓	40 V (drain)	✓	✓	LQFP-32
NCV7517B	Hex LS Pre-Driver	16-bit	✓	external MOSFET	✓	40 V (drain)	✓	✓	LQFP-32
NCV7518	Hex Low-Side	16-bit	✓	external MOSFET	✓	48 V (load)	✓	✓	QFN32
NCV7519	Hex Low-Side	16-bit	✓	external MOSFET	✓	48 V (load)	✓	✓	QFN32
NCV7520MW	Hex Low-Side	16-bit	✓	external MOSFET	✓	48 V (load)	✓	✓	QFN32
NCV7520MW	Hex Low-Side	16-bit	✓	external MOSFET	✓	48 V (load)	✓	✓	TQFP-32 EP
NCV33152	High Speed Dual PreDriver	–	✓	external MOSFET		20 V (V _{DD})			SOIC-8
NCV7535	H-Bridge	24-bit	✓	external MOSFET	5 V	40 V		✓	TSSOP-20

Smart Drivers & Bridges

Drivers

	Device	Description	SPI	Direct Control	Load Current	I _{lim} Min	V _S Op	V _S Max	R _{dson} Max @ 25°C (HS/LS)	Package
Full Bridge	NCV7702B	Configurable Dual H-Bridge	–	✓	–	1 A	7 - 16 V	60 V	–	SOIC-24
	NCV7710	H-Bridge	24-Bit		3 A	6 A	5.5 - 28 V	40 V	Typ 150 mΩ, Max 180 mΩ	SSOP-36 EP
	NCV7708E	Hex HS/LS Driver	SPI: 16-bit		1 A	1 A	5.5 - 40 V	40 V	0.8 Ω	SOIC-28W
	NCV7708F	Hex HS/LS Driver	SPI: 16-bit		1 A	1 A	5.5 - 40 V	41 V	0.8 Ω	SSOP-24 EP
	NCV7608	Configurable HS/LS Driver	SPI: 16-bit	✓	0.35 mA	0.8 A	3 - 28 V	40 V	1.2 Ω	SOIC-28W
Multi-Channel LS	NCV7240B	8x LS Driver	SPI: 16-Bit	Limp Home Feature	–	0.6 A	5.5 V (V _{DD} /V _{DDA})	5.5 V (V _{DD} /V _{DDA})	1.5 Ω	SSOP-24
	NCV7754	8x LS Driver	SPI: 16-Bit	Limp Home Feature	–	0.5 A	5.5 V (V _{DD} /V _{DDA})	5.5 V (V _{DD} /V _{DDA})	0.8 Ω	SSOP-24
	NCV7751	12x LS Driver	SPI: 16/24/32-Bit			0.6 A	5.5 V (V _{DD} /V _{DDA})	5.5 V (V _{DD} /V _{DDA})	1.2 Ω	SSOP-24 EP
	NCV7748	8x LS Driver	LIN		0.3 A/0.4 A	0.6 A/0.75 A	6 - 18 V	40 V	0.8 Ω/1.5 Ω	SOIC-14
Half-Bridge HB, HS, LS	NCV7707	Front Door-Module Driver (3x Full-Bridge, 5x HS, 1x LS)	SPI: 24-bit		–	HB: 0.75 A/3 A/6 A HS: 0.3 A/2.5 A/6 A LS: 0.75 A	5.5 - 28 V	40 V	HB: 1.6 Ω/300 mΩ/150 mΩ HS: 1.4 Ω/300 mΩ/600 mΩ/300 mΩ/100 mΩ LS: 1.6 Ω	SSOP-36 EP
	NCV7705	Mirror Driver (4x Half-Bridge, 4x HS, 1x LS)	SPI: 24-bit		–		5.5 - 28 V	40 V	HB: 1.6 Ω/300 mΩ HS: 1.4 Ω/300 mΩ/600 mΩ/300 mΩ/100 mΩ LS: 1.6 Ω	SSOP-36 EP
	NCV7714	Mirror Driver (3x Half-Bridge, 4x HS, 1x LS)	SPI: 24-bit		–		5.5 - 28 V	40 V	HB: 1.6 Ω HS: 1.4 Ω/300 mΩ LS: 1.6 Ω	SSOP-36 EP
	NCV7704	Mirror Driver (3x Half-Bridge, 4x HS)	SPI: 24-bit		–		5.5 - 28 V	40 V	HB: 1.6 Ω HS: 1.4 Ω/300 mΩ	SSOP-36 EP
Half-Bridge	NCV7721	Single H-Bridge Driver	–	✓	1 A					SSOP-36 EP
	NCV7703C	Triple HS/LS Half-Bridge	SPI: 16-bit		1 A	1 A	5.5 - 40 V	40 V	0.8 Ω	SOIC-14
	NCV7718B	Hex Half-Bridge	SPI: 16-bit		1 A	1 A	4.5 - 40 V	40 V	1.1 Ω	SOIC-14
	NCV7719	Octal Half-Bridge	SPI: 16-bit		0.5 A	0.8 A	4.5 - 40 V	40 V	1.1 Ω	SSOP-24 EP
	NCV7720	10x Half-Bridge	SPI: 16-bit		0.5 A	0.8 A	4.5 - 40 V	40 V	1.1 Ω	SSOP-24 EP
	NCV7726	12x Half-Bridge	SPI: 16-bit		0.5 A	0.8 A	4.5 - 40 V	40 V	1.1 Ω	SSOP-24 EP

Wide Selection of Automotive Grade Operational Amplifiers and Comparators

Comparators

Device	Channels	V _S Min (V)	V _S Max (V)	I _Q /Channel (μA)	t _{RESP} (μs)	V _{OS} Max (mV)	I _{OUT} (mA)	Output Type	Features	Package(s)
NCV2393	2	2.7	16	9	0.8	5	20	Open Drain	V _S Range, Ultra-Low I _Q	SOIC-8
NCV2200	1	0.85	6	10	0.7	5	70	Complementary	Low I _Q , Fast t _{RESP}	SOT-23-5
NCV331	1	2.7	5	40	0.5	9	84	Open Drain	Ultra-Low I _Q	TSOP-5
NCV2903	2	2	36	200	1.5	15	16	Open Collector	Low Cost	SOIC-8, MICRO8
NCV2901	4	3	36	250	1.3	7	16	Open Collector	Low Cost	SOIC-14, TSSOP-14, Bare Die
NCV391	1	2	36	500	0.35	9	16	Open Collector	Small Package, Fast t _{RESP}	SOT-23-5

Operational Amplifiers

Device	Channels	V _S Min (V)	V _S Max (V)	I _Q /Channel (mA)	GBW (MHz)	V _{OS} Max (mV)	V _{OS} Drift (μV/°C)	I _B (nA)	CMRR (dB)	e _n (nV/√Hz)	Rail to Rail	Features	Package(s)
NCV33172	2, 4	3	44	0.18	1.8	6.5	10	20	90	32	–	Up to 44 V supply	SOIC-8, TSSOP-14
NCV2003/32/34	1, 2, 4	1.7	5.5	0.27	7	5	2	0.001	80	20	Output	8 V/μs Slew Rate	SOT-23-5, SOT-553, Micro8, SOIC-8, TSSOP-8, SOIC-14
NCV20071/2/4	1, 2, 4	2.7	36	0.4	3	4	2	0.005	110	30	Output	Up to 36 V supply & RRO	SOT-553, TSOP-5, Micro8, SOIC-8, TSSOP-8, TSSOP-14, SOIC-14
NCV2002	1	0.9	7	0.48	0.9	6	8	0.01	82	100	I/O	Shutdown, supply down to 0.9 V	TSOP-6
NCV2904	2	3	32	0.75	1	7	7	45	70	–	–	Low cost	SOIC-8, Micro8
NCV33202/4	2, 4	1.8	12	0.9	2.2	6	2	80	90	20	I/O	High output current & drive	SOIC-8, Micro8, SOIC-14, TSSOP-14
NCV952	2	2.7	12	0.9	3	8	2	35	80	25	I/O	26 V rail-to-rail I/O	TSSOP-8
NCV7101	1	1.8	10	1.0	1	9	8	0.001	60	140	I/O	Ultra-low I _B	SOT-23-5
NCV2902	4	3	32	1.2	1	7	7	90	70	–	–	Low cost	SOIC-14, TSSOP-14
NCV33072/4	2, 4	3	44	1.6	4.5	3	10	100	97	32	–	44 V supply & fast Slew Rate	SOIC-8, TSSOP-14
NCV833	2	10	36	2	15	5	2	300	100	4.5	–	V _S Range, low e _n	SOIC-8
NCV33078	2, 4	5	18	2.1	16	2	2	300	100	4.5	–	Wide GBW, low V _{OS} & e _n	SOIC-8, SOIC-14
NCV33079	2, 4	5	18	2.1	16	2	2	300	100	4.5	–	Wide GBW, low V _{OS} & e _n	SOIC-8, SOIC-14
NCV33272/4A	2, 4	3	36	2.2	24	1	2	300	100	18	–	Wide GBW, V _S range	SOIC-8, SOIC-14, TSSOP-14
NCV20062	2	1.8	5.5	0.14	3	4	1	0.001	80	20	I/O	Low power & RRIO	Micro8, TSSOP-8, SOIC-8
NCV20082	2	1.8	5.5	0.05	1.2	4	1	0.001	80	30	I/O	Low power & RRIO	Micro8, TSSOP-8, SOIC-8
NCV20092	2	1.8	5.5	0.02	0.35	4	1	0.001	80	40	I/O	Low power & RRIO	Micro8, TSSOP-8, SOIC-8

Power Operational Amplifiers (I_{OUT} ≥ 250 mA)

Device	Channels	I _{OUT} (A)	V _S Min (V)	V _S Max (V)	I _Q /Channel (mA)	GBW (MHz)	V _{OS} Max (mV)	V _{OS} Drift (μV/°C)	I _B (nA)	Slew Rate (μV/°C)	Features	Package(s)
NCV5652	2	0.5	3.3	13.2	4	0.35	–	2	200	1	Thermal flag & shutdown, excellent Vol	DFN-12
NCV0372	2	1	5	40	2.5	1.4	20	20	100	1.4	Thermal shutdown	PDIP-8, PDIP-16, SOIC-16W, SOEIAJ-16

Zero Drift Precision/Current Sense Operational Amplifiers

Device	Channels	V _S Min (V)	V _S Max (V)	Input CM Range (V)	I _Q /Channel (μA)	GBW (MHz)	V _{OS} Max (μV)	V _{OS} Drift (μV/°C)	Gain Error (%)	CMRR (dB)	e _n (nV/√Hz)	Features	Package(s)
NCV21x*	1	2.7	26	2.7 to 26	65	14	35	0.5	1	140	–	Up to 26 V CMVIR	SC-70
NCV333/2333/4333	1, 2, 4	1.8	5.5	V _{SS} -0.1 to V _{DD} +0.1	21	350	10	0.03	–	120	1	Low V _{OS}	SOT-23-5, SC-70-5, DFN-8, Micro8, SOIC-8, SOIC-14

* Fixed Gain options = 50, 75, 100, 200, 500, 1000.

COMPONENTS

EEPROMs for Personalization of Comfort and Entertainment Features

Grade 0 EEPROMs

Device	Density	Vcc Min (V)	Vcc Max (V)	Temperature Range (°C)	Package(s)
NV25010	1 kb	1.7 / 2.5	5.5	-40 to +150	SOIC-8, TSSOP-8
NV25020	2 kb	1.7 / 2.5	5.5	-40 to +150	SOIC-8, TSSOP-8
NV25040	4 kb	1.7 / 2.5	5.5	-40 to +150	SOIC-8, TSSOP-8
NV25080	8 kb	1.7 / 2.5	5.5	-40 to +150	SOIC-8, TSSOP-8
NV25160	16 kb	1.7 / 2.5	5.5	-40 to +150	SOIC-8, TSSOP-8
NV25320	32 kb	1.7 / 2.5	5.5	-40 to +150	SOIC-8, TSSOP-8
NV25640	64 kb	1.7 / 2.5	5.5	-40 to +150	SOIC-8, TSSOP-8

Grade 1 Features

- -40°C to +125°C
- 1 kb to 1 Mb density range available
- 1 million cycle program/erase

Grade 1 EEPROMs

Interface Protocol	Device	Density	Organization	Vcc Min (V)	Vcc Max (V)	f _{clk} Max (MHz)	Package(s)
I2C	CAV24M01	1 Mb	128k x 8	2.5	5.5	1	SOIC-8, TSSOP-8
	CAV24C512	512 kb	64k x 8	2.5	5.5	1	SOIC-8, TSSOP-8
	CAV24C256	256 kb	32k x 8	2.5	5.5	1	SOIC-8, TSSOP-8
	CAV24C128	128 kb	16k x 8	2.5	5.5	1	SOIC-8, TSSOP-8
	CAV24C64	64 kb	8k x 8	2.5	5.5	0.4	SOIC-8, TSSOP-8
	CAV24C32	32 kb	4k x 8	2.5	5.5	0.4	SOIC-8, TSSOP-8
	CAV24C16	16 kb	2k x 8	2.5	5.5	0.4	SOIC-8, TSSOP-8
	CAV24C08	8 kb	1k x 8	2.5	5.5	0.4	SOIC-8, TSSOP-8
	CAV24C04	4 kb	512 x 8	2.5	5.5	0.4	SOIC-8, TSSOP-8
CAV24C02	2 kb	256 x 8	2.5	5.5	0.4	SOIC-8, TSSOP-8	
SPI	CAV25M01	1 Mb	128k x 8	2.5	5.5	10	SOIC-8, TSSOP-8
	CAV25512	512 kb	64k x 8	2.5	5.5	10	SOIC-8, TSSOP-8
	CAV25256	256 kb	32k x 8	2.5	5.5	10	SOIC-8, TSSOP-8
	CAV25128	128 kb	16k x 8	2.5	5.5	10	SOIC-8, TSSOP-8
	CAV25640	64 kb	8k x 8	2.5	5.5	10	SOIC-8, TSSOP-8, TDFN-8
	CAV25320	32 kb	4k x 8	2.5	5.5	10	SOIC-8, TSSOP-8
	CAV25160	16 kb	2k x 8	2.5	5.5	10	SOIC-8, TSSOP-8
	CAV25080	8 kb	1k x 8	2.5	5.5	10	SOIC-8, TSSOP-8
	CAV25040	4 kb	512 x 8	2.5	5.5	10	SOIC-8, TSSOP-8
	CAV25020	2 kb	256 x 8	2.5	5.5	10	SOIC-8, TSSOP-8
	CAV25010	1 kb	128 x 8	2.5	5.5	10	SOIC-8, TSSOP-8
Microwire	CAV93C86	16 kb	2k x 8 / 1k x 16	2.5	5.5	2	SOIC-8, TSSOP-8
	CAV93C76	8 kb	1k x 8 / 512 x 16	2.5	5.5	2	SOIC-8, TSSOP-8
	CAV93C66	4 kb	512 x 8 / 256 x 16	2.5	5.5	2	SOIC-8, TSSOP-8
	CAV93C56	2 kb	256 x 8 / 128 x 16	2.5	5.5	2	SOIC-8, TSSOP-8
	CAV93C46	1 kb	128 x 8 / 64 x 16	2.5	5.5	2	SOIC-8, TSSOP-8

Grade 0 Features

- -40 to +150°C
- SPI interface protocol
- Voltage supply range: 1.7 – 5.5 V up to +125°C; 2.5 – 5.5 V up to +150°C

EasyPRO™ is a user-friendly, portable programming tool for ON Semiconductor serial EEPROMs (I2C, SPI, Microwire)

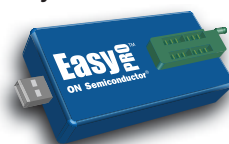

Micro-Stepping Motor Drivers for Enhanced Positioning Resolution

Features

- Micro-stepping technology
- Embedded sensorless step-loss and stall detection
- Configurable for different motor types
- On-chip positioner – AMIS-30623

Stepping Motor Drivers

Device	Interface	Integrated Linear Regulator	Sensorless Stall Detection	Peak Transient (V)	Peak Current (mA)	Package
AMIS-30621	LIN	✓		40	800	SOIC-20, NQFP-32
AMIS-30622	I ² C	✓		40	800	SOIC-20
AMIS-30623	LIN	✓	✓	40	800	SOIC-20, NQFP-32

Integrated, Reliable Drive Circuits for Motors and Electro-Mechanical Relays

Most relays mounted to a PCB require a relay driver circuit!

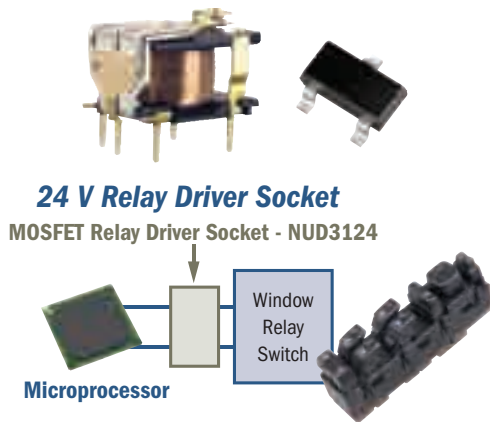

Features

- Integrates diodes, resistors and capacitors into one circuit
- Delivers additional current to the relay coil and protects against ESD
- Meets IEC61000-4-4 Electrical Fast Transient (EFT) test standards

Relay Drivers

Device	Configuration	Circuit Type *	Voltage (V)	Current (mA)	Package(s)
SZNUD3124	Single	MOSFET	24	150	SOT-23
SZNUD3124D	Dual	MOSFET	24	150	SC-74
SZNUD3160	Single	MOSFET	60	150	SOT-23
SZNUD3160D	Dual	MOSFET	60	150	SC-74

* MOSFET: the driver circuit consists of a MOSFET combined with resistors and diodes.

Integrated Circuit Elements with Self-Protected MOSFET Solutions

ON Semiconductor supplies self-protected MOSFETs that may include current limiting, temperature limiting, ESD protection, or a current mirror. The portfolio of smart MOSFETs integrates analog circuit elements for protection and diagnostics within power MOSFETs.

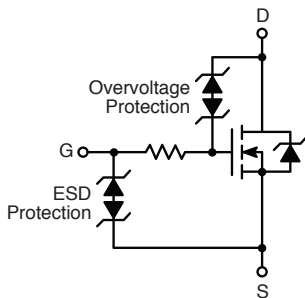

Clamping MOSFET

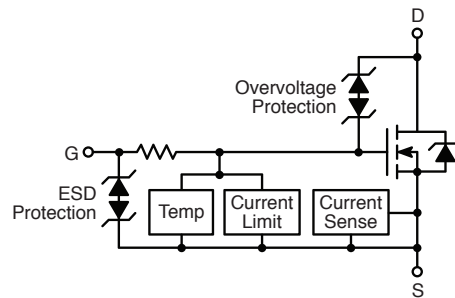

Low-Side Protected MOSFET

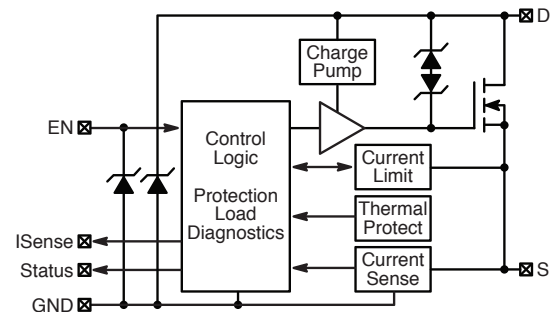

High-Side Protected MOSFET

Clamp FET Features (E-FET)

- Gate-to-Source protection
- Over-voltage protection
- Internal series Gate resistance
- Clamp voltage range 40-50 V

Protected Low-Side Switch

- Short circuit protection
- Current limit
- Thermal shut-down with restart
- ESD protection
- Overvoltage clamped protection

Protected High-Side Switch

- Charge pump
- Short circuit protection
- Current limit
- Temperature limit and shut-down
- ESD protection
- Overvoltage clamped protection
- Diagnostic output
- Loss of ground detection
- Open and underload detection
- Over and undervoltage detection

Self-Protected MOSFETs

Device	Description	Channels	Package(s)
LOW SIDE			
NCV8401A	Low Side Protected MOSFET, 23 mΩ	1	DPAK
NCV8402A	Low Side Protected MOSFET, 165 mΩ	1	SOT-223
NCV8402AD	Dual Low Side Protected MOSFET, 165 mΩ	2	SOIC-8
NCV8403A	Low Side Protected MOSFET, 60 mΩ	1	SOT-223, DPAK
NCV8405A	Low Side Protected MOSFET, 100 mΩ	1	SOT-223, DPAK
NCV8406A	Low Side Protected MOSFET, 210 mΩ	1	SOT-223, DPAK
NCV8408	Low Side Protected MOSFET, 65 mΩ	1	SOT-223
NCV8440A	Clamped MOSFET, 95 mΩ	1	SOT-223
HIGH SIDE			
NCV8450A	High Side Protected MOSFET, 1 Ω	1	SOT-223
NCV8452	High Side Protected MOSFET, 200 mΩ	1	SOT-223
NCV8460A	High Side Protected MOSFET w\Digital Diagnostics, 60 mΩ	1	SOIC-8
NCV8461	High Side Protected MOSFET w\Digital Diagnostics, 350 mΩ	1	SOIC-8

New Rectifier Packaging Solutions for Automotive

Features

- Low forward voltage drop for improved efficiency
- High forward surge current capabilities
- Fast switching Schottky rectifiers can operate at high frequencies
- Small SOD-123FL, SMA, SMB, SMC and DPAK options to reduce board area
- Capable of use as freewheeling diodes, output rectifiers, energy recirculation diodes, and for polarity protection

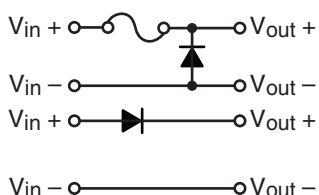

Polarity Protection

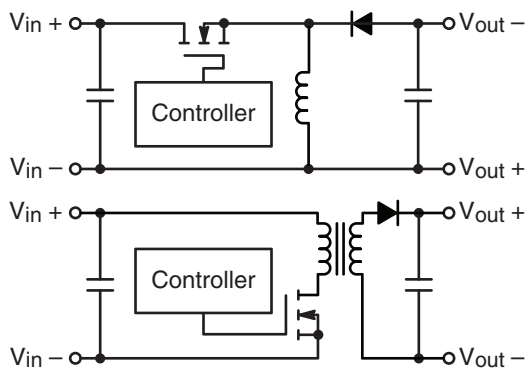

Freewheeling and Output Rectification

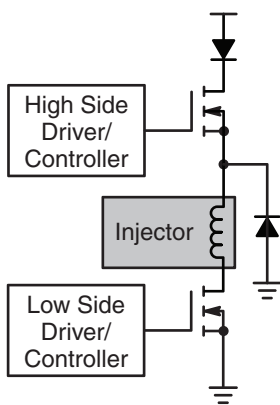

Engine Control and Energy Recirculation Diodes

Polarity Protection Rectifiers

Device	V _{RRM} (V)	I _{O(rec)} (A)	Package
NRVBS360	60	3	SMC
SBRD8360	60	3	DPAK
NRVBD660CT	60	6	DPAK
SBRD81045	45	10	DPAK
SBRB1045	45	10	D2PAK
NRVBB1645	45	16	D2PAK
NRVBB2060CT	60	20	D2PAK
SBRB2545CT	45	30	D2PAK
NRVBB30H60CT	60	30	D2PAK
NTSB30100CT	100	30	D2PAK
NTSB30U100CT	100	30	D2PAK
NRVBB4030	30	40	D2PAK
NTSB40120CT	120	40	D2PAK
NTSB60100CT	100	60	D2PAK

Freewheeling and Output Rectification Rectifiers

Device	V _{RRM} (V)	I _{O(rec)} (A)	Package
NRVB140SF	40	1	SOD-123FL
NRVB140ESF	40	1	SOD-123FL
NRVBA140	40	1	SMA
SBRS8140	40	1	SMB
NRVB1H60SF	60	1	SOD-123FL
NRVBA160	60	1	SMA
MBRAF1100	100	1	SMA Flat
SURHS8160	600	1	SMB
NRVBAF1540	40	1.5	SMA Flat
NRVBS2040L	40	2	SMB
NRVBS240L	40	2	SMB
NRVTSM260	60	2	Powermite
NRVB2H60SF	60	2	SOD-123FL
NRVBAF260	60	2	SMA Flat
NRVBS260	60	2	SMB
MBRAF2H100	100	2	SMA Flat
NRVBA340	40	3	SMA
SBRS8340	40	3	SMC
SBRD8340	40	3	DPAK
NRVBAF360	60	3	SMA Flat
NRVBAF3200	200	3	SMA Flat
MBRAF440	40	4	SMA Flat
NRVBS540	40	5	SMC
SURHD8560	600	5	DPAK
NRVBD640CT	40	6	DPAK
SBRB1545CT	45	15	D2PAK
NRVBB3030CTL	30	30	D2PAK

SO-8 Flat Lead Rectifiers

Device	V _{RRM} (V)	I _{O(rec)} (A)	Package
NRVB440MFS	40	4	SO-8FL
NRVB460MFS	60	4	SO-8FL
NRVB540MFS	40	5	SO-8FL
NRVB560MFS	60	5	SO-8FL
NRVB5100MFS	100	5	SO-8FL
NRVB5H100MFS	100	5	SO-8FL
NRVB860MFS	60	8	SO-8FL
NRVB8H100MFS	100	8	SO-8FL
NRVB1045MFS	45	10	SO-8FL
NRVB10100MFS	100	10	SO-8FL
NRVTS10100EMFS	100	10	SO-8FL
NRVTS10120EMFS	120	10	SO-8FL
NRVB1240MFS	40	12	SO-8FL
NTS12100EMFS	100	12	SO-8FL
NRVTS12120EMFS	120	12	SO-8FL
NRVB2045MFS	45	20	SO-8FL
NRVB2045EMFS	45	20	SO-8FL
NRVB30H100MFS	100	30	SO-8FL
MBR5H100MFS	100	5	SO-8FL

Energy Recirculation Rectifiers

Device	V _{RRM} (V)	I _{O(rec)} (A)	Package
NRVB1H100SF	100	1	SOD-123FL
NRVBA1H100	100	1	SMA
SBRS81100	100	1	SMB
SURA8110	100	1	SMA
SURS8110	100	1	SMB
SURA8120	200	1	SMA
SURS8120	200	1	SMB
NRVB2H100SF	100	2	SOD-123FL
NRVBA2H100	100	2	SMA
NBRS2H100	100	2	SMB
SURA8210	100	2	SMA
SURS8210	100	2	SMB
NRVHPM220	200	2	Powermite
NRVHP220SF	200	2	SOD-123FL
SURA8220	200	2	SMA
SURS8220	200	2	SMB
NRVBS3100	100	3	SMC
NRVBS3200	200	3	SMB
NRVBS3201	200	3	SMC
SURS8320	200	3	SMC
NRVB4201	200	4	SMC
NBRD5H100	100	5	DPAK

Robust Standard Logic Families

Standard CMOS

Metal Gate*

- 3.0 to 18.0 V
- 3 mA Drive
- Typical Propagation Delay 35 ns
- -55 to +125°C

High Speed*

- 2.0 to 6.0 V
- 4 mA Drive
- Typical Propagation Delay 25 ns
- -55 to +125°C

FACT

- 3.0 to 5.0 V
- 24 mA Drive
- Typical Propagation Delay 10 ns
- -40 to +85°C

MiniGate™*

- 0.9 to 5.5 V
- 2 to 24 mA Drive**
- Typical Propagation Delay 2 to 7 ns**
- -55 to +125°C

* Automotive grade available. **Specifications dependent on device type.

Low Voltage CMOS

VHC*

- 2.0 to 5.5 V
- 8 mA Drive
- Typical Propagation Delay 8 ns
- -55 to +125°C

LCX*

- 1.65 to 5.5 V
- 24 mA Drive
- Typical Propagation Delay 5 ns
- -40 to +85°C

LVX*

- 2.0 to 3.6 V
- 6 mA Drive
- Typical Propagation Delay 20 ns
- -40 to +85°C

Standard Logic Nomenclature

	Family	Nomenclature
Standard	Metal Gate	MC14xxx
	High Speed	MC74HCxxx, 74HCxxx
	FACT	MC74AC/Txxx
Low Voltage	VHC	MC74VHC/Txxx
	LCX	MC74LCXxxx
	LVX	MC74LVXxxx
MiniGate™	High Speed	MC74HC1Gxxx
	VHC	MC74VHC/T1Gxxx
	LCX	NL17SZxxx, NL27WZxxx, NL37WZxxx
	NLU	NLUngxxx

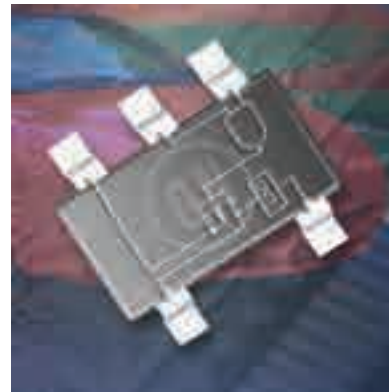

OmniClock Programmable Clock Synthesizers

Key Features

- Single PLL
- Input Frequency Range:
 - Crystal: 3 – 50 MHz (low cost ESR crystal compatible)
 - Clock: 3 – 200 MHz (single-ended only)
- Up to 3 single-ended (LVCMOS/LVTTL) outputs, or up to 1 differential (LVPECL, LVDS, HCSL or CML) output + 1 single-ended (LVCMOS/LVTTL) output
- Output Frequency Range: 8 kHz (Min), 200 MHz (Max)
- Programmable Spread Spectrum Capabilities for EMI Suppression
 - Center Spread (0.125% steps): $\pm 0.125\%$ to $\pm 3\%$
 - Down Spread (0.25% steps): -0.25% to -4%
 - Modulation Rate: 30 kHz – 130 kHz
- PLL Bypass mode
- Individual Output Enable pin for each output and Power Down Capability
- Individual Output Voltage pins per output, allowing setting of output voltage (1.8 V, 2.5 V or 3.3 V; equal to or less than VDD)
- Automatic Gain Control (Crystal Power Limiting)
- Programmable internal input crystal load capacitors
- Programmable Output Drive current
- Up to 4 independent configurations using SELx pins
- Supply Voltage: 3.3 V $\pm 10\%$; 2.5 V $\pm 10\%$; 1.8 V ± 0.1 V
- Temperature Range: -40°C to $+85^{\circ}\text{C}$
- Available in QFN-16 (3 mm x 3 mm) and WDFN-8 (2 mm x 2 mm) packages

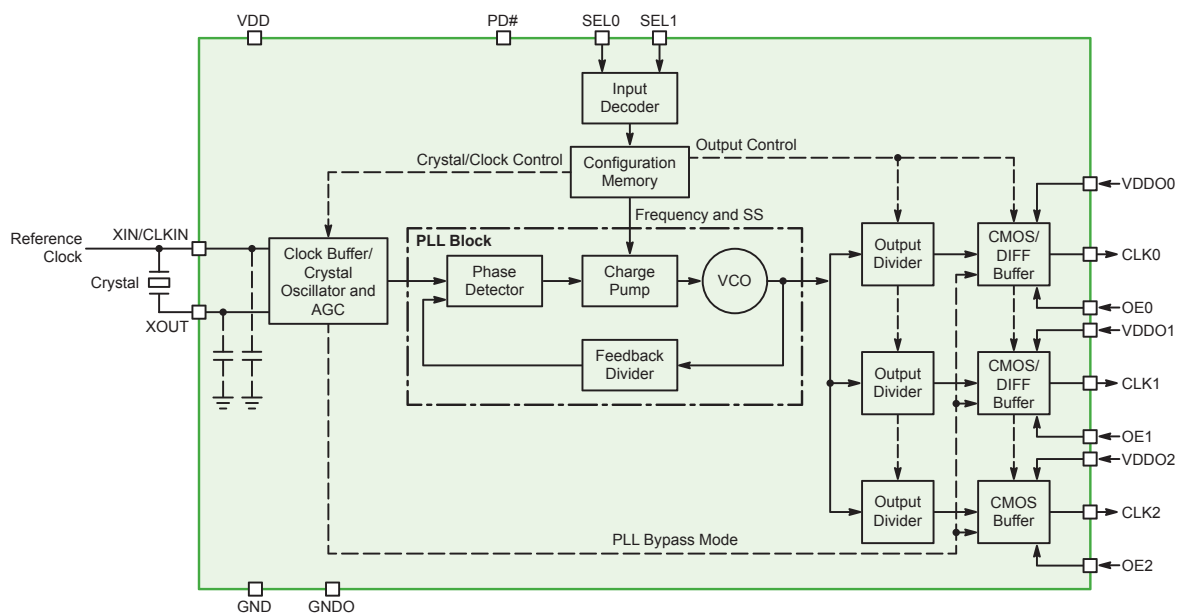

Block Diagram

OmniClock Programmable Clock Synthesizers

Using OmniClock in Your System

Customer orders blank OmniClock devices

Customer uses free GUI and supplied evaluation board to configure the blank device to the desired parameters: frequency, drive strength, spread spectrum, etc.

Customer provides configuration file to ON Semiconductor sales channel

ON Semiconductor programs device in factory with desired customer configuration, and creates customer-specific part number

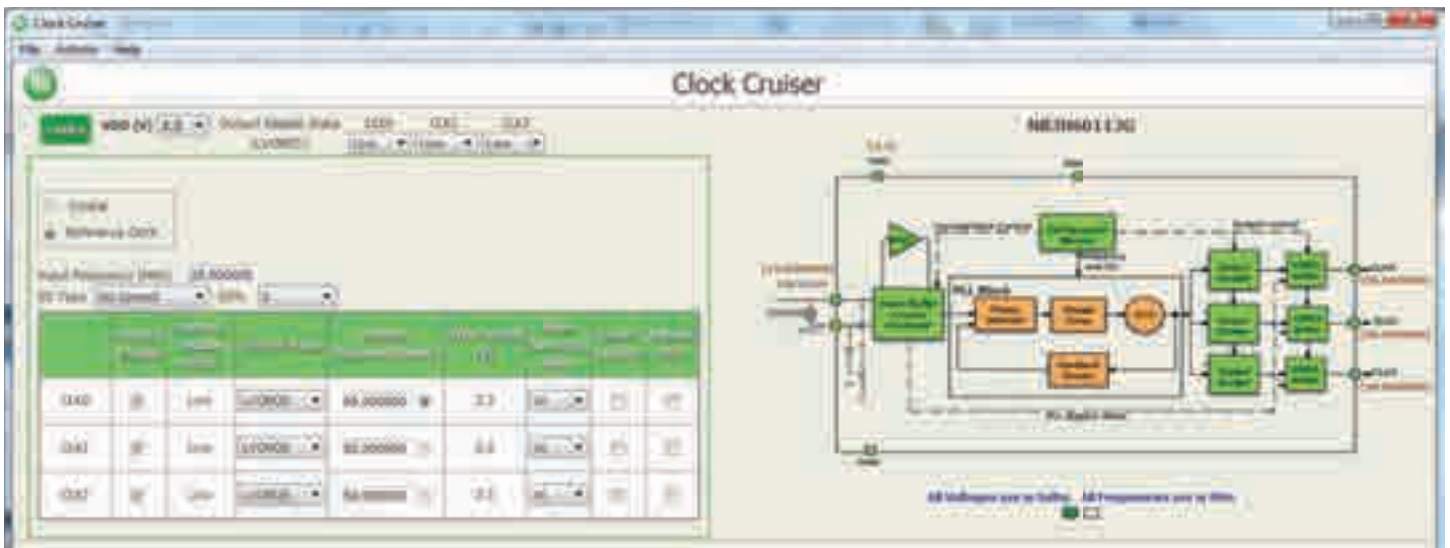

Configuration GUI

Device	Individual OE	Individual V _{ddo}	Supply Voltage (V)	Number of Configurations	Number of Outputs	Package
NB3H63143G	Yes	Yes	2.5 / 3.3	4	3	QFN-16
NB3H60113G	No	No	2.5 / 3.3	1	3	DFN-8
NB3V63143G	Yes	Yes	1.8	4	3	QFN-16
NB3V60113G	No	No	1.8	1	3	DFN-8

COMPONENTS

Clock Generation and Distribution

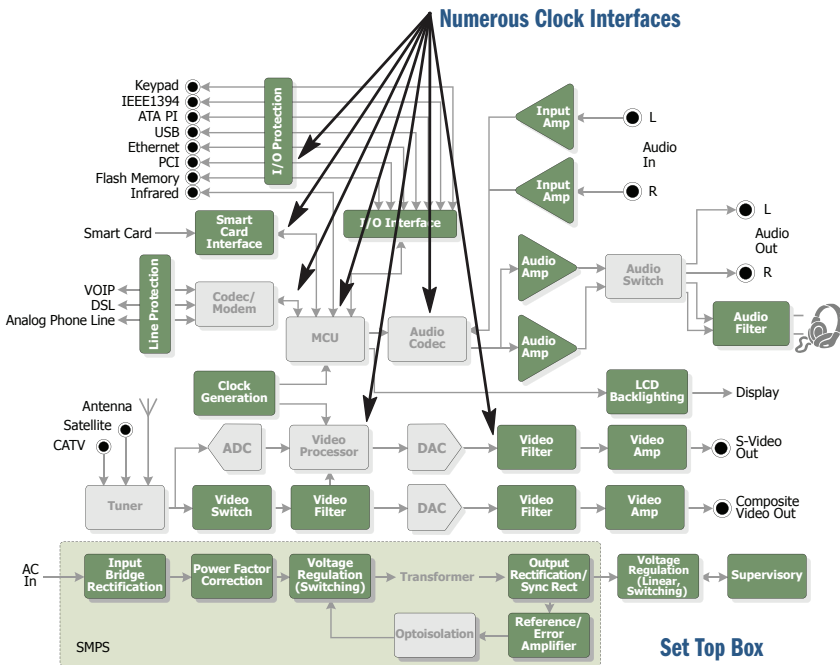

Programmable PLL Clocks can satisfy all clock tree requirements in a single device

- Replace all clock interfaces with one Multi-PLL Programmable Clock
- Maintain clock architecture flexibility by being able to program new clock configurations through software
- Key devices
 - Clock Multiplier: NB3N3020
 - Single PLL I2C: FS7140, FS7145
 - Three PLL I2C EEPROM: FS6370, FS6377

Clock Buffers

Device	VCC (V)	Output Freq (MHz)	Outputs	Type	Package
NB3N551	3.3, 5.0	180	4	Fanout Buffer	SOIC-8, DFN-8
NB3L553	2.5, 3.3, 5.0	200	4	Fanout Buffer	SOIC-8, DFN-8
NB3N2304NZ	3.3	140	4	Low Skew Fanout Buffer	TSSOP-8, DFN-8
PCS2I2309NZ	3.3	133	9	Clock Fanout Buffer	SOIC-16
NB2305A	3.3	15-133	5	Zero Delay Buffer	TSSOP-8, SOIC-8
NB2309A	3.3	15-133	9	Zero Delay Buffer	TSSOP-16, SOIC-16
NB2304A	3.3	15-133	4	Zero Delay Buffer	SOIC-8
NB3N200S	3.3	100	1	M-LVDS Driver/Receiver	SOIC-8
NB3N201S	3.3	100	1	M-LVDS Driver/Receiver	SOIC-8
NB3N206S	3.3	100	1	M-LVDS Driver/Receiver	SOIC-8

3.3 V Clock Generators with Fixed Frequency Outputs

Device	Output Frequency (MHz)	Application	Package
NB3N3002	25, 125, 200	PCI-e, Gigabit Ethernet	TSSOP-16
NB3N511	14-200 with selectable multiplier ratios	USB, PCI, PCI-e, SDRAM, Ethernet, Gigabit Ethernet, CPU	SOIC-8
NB3N502	14-120	CPU, USB, PCI, Network, Ethernet	SOIC-8
NB3N5573	25, 100, 125, 200	PCI-e, DIMM, CPU	TSSOP-16

Active EMI Solutions for Display Interfaces

The display interface in infotainment applications is usually routed using flex-PCB cables, which may cause EMI problems. Timing-Safe™ technology from ON Semiconductor allows active EMI reduction in interfaces where the data and clock are synchronized, and still maintain the synchronization of data and clock after SSC is applied to the clock. The active EMI portfolio supports different frequency ranges, supply voltages, spread settings, output drives, and packages.

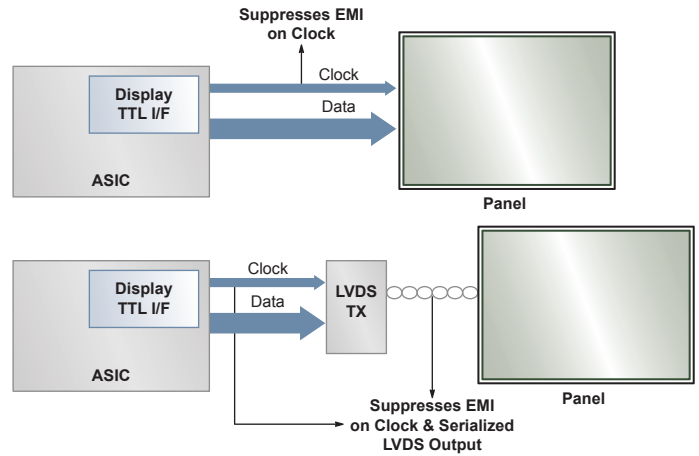

Device	VCC (V)	Frequency Range (MHz)	Temperature Range (°C)	Features	Package(s)
P3PS850BH	2.3 - 3.6	18 - 72	-20 to +85	Power down pin; analog SS % control; in-out delay control	WDFN-8

Timing Safe Technology maintains data synchronization on clock line

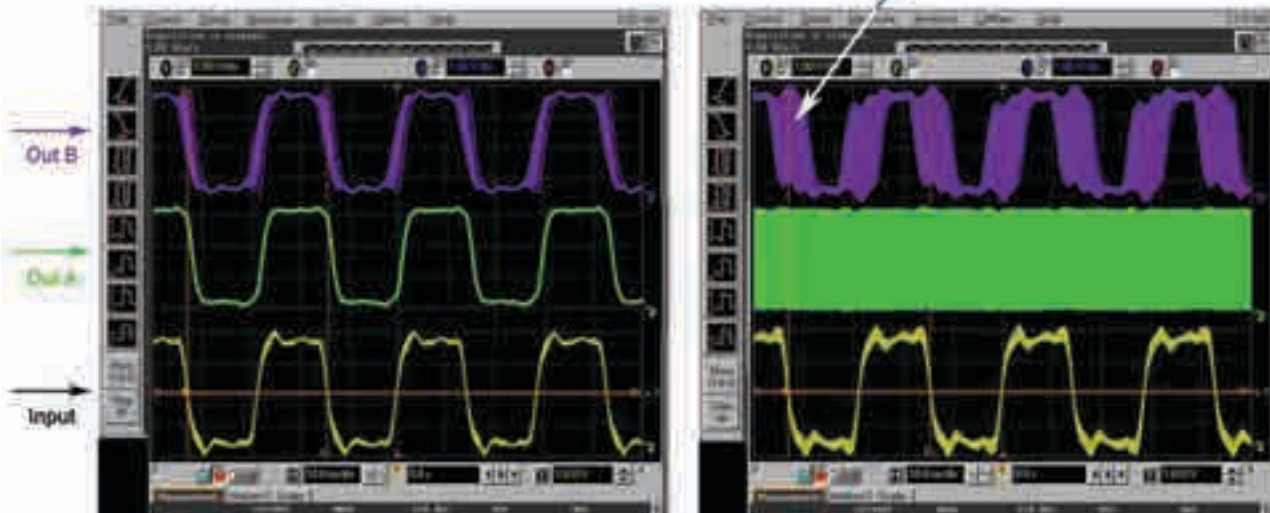

Spread Spectrum Disabled

Spread Spectrum Enabled

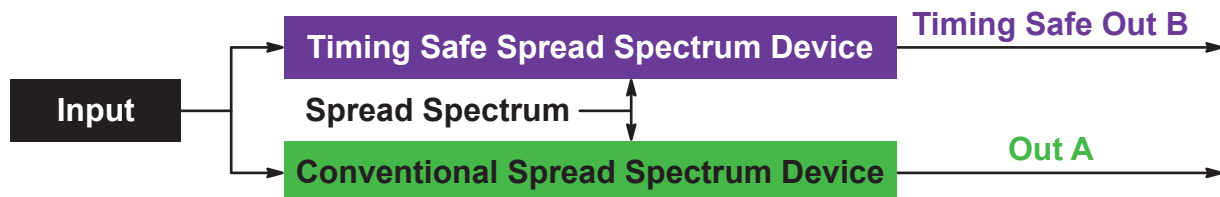

COMPONENTS

Multipoint M-LVDS Drivers/Receivers

Low voltage (3.3 V) differential 30-55 ohm line drivers and receivers, for signaling rates up to 200 Mbps.

Features

- Threshold to Detect Open-Circuit and Idle-Bus conditions
- Controlled driver output voltage transition times for improved signal quality
- -1 V to 3.4 V common-mode voltage range allows data transfer up to 2 V of ground noise
- Supports Simplex and Half Duplex bus configuration
- Temperature range -40°C to 125°C

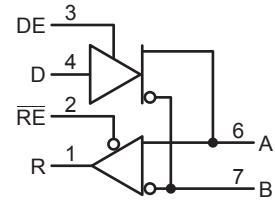

Device	Receiver	Bus Configurations	Peak-to-Peak Jitter Max (ps)	Device-to-Device Skew Max (ps)	Driver Pulse Skew Max (ps)	Package
NBA3N200S	Type 1	Simplex	150	0.9	150	SOIC-8
NBA3N201S	Type 1	Simplex	150	1	100	SOIC-8
NBA3N206S	Type 2	Simplex; Half-Duplex	130	1	100	SOIC-8

Offices

AUSTRIA

Vienna
Phone: +43 186 642 300
Fax: +43 186 642 350
wien@avnet.eu

BELGIUM

Merelbeke
Phone: +32 9 210 24 70
Fax: +32 9 210 24 87
gent@avnet.eu

BULGARIA

Sofia
sofia@avnet.eu

CZECH REPUBLIC (SLOVAKIA)

Prague
Phone: +420 234 091 031
Fax: +420 234 091 030
praha@avnet.eu

DENMARK

Herlev
Phone: +45 432 280 10
Fax: +45 432 280 11
herlev@avnet.eu

ESTONIA

(LATVIA, LITHUANIA)
Pärnu
Phone: +372 56 637737
paeruu@avnet.eu

FINLAND

Espoo
Phone: +358 207 499 200
Fax: +358 207 499 280
helsinki@avnet.eu

FRANCE (TUNISIA)

Cesson Sévigné
Phone: +33 299 838 485
Fax: +33 299 838 083
rennes@avnet.eu

Illkirch

Phone: +33 390 402 020
Fax: +33 164 479 099
strasbourg@avnet.eu

Massy Cedex

Phone: +33 164 472 929
Fax: +33 164 470 084
paris@avnet.eu

Toulouse

Phone: +33 05 62 47 47
toulouse@avnet.eu

Vénissieux Cedex

Phone: +33 478 771 360
Fax: +33 478 771 399
lyon@avnet.eu

GERMANY

Berlin
Phone: +49 30 214 882 0
Fax: +49 30 214 882 33
berlin@avnet.eu

Freiburg

Phone: +49 761 881 941 0
Fax: +49 761 881 944 0
freiburg@avnet.eu

Hamburg

Phone: +49 40 608 235 922
Fax: +49 40 608 235 920
hamburg@avnet.eu

Holzwickede

Phone: +49 2301 919 0
Fax: +49 2301 919 222
holzwickede@avnet.eu

Lehrte

Phone: +49 5132 5099 0
hannover@avnet.eu

Leinfelden-Echterdingen

Phone: +49 711 782 600 1
Fax: +49 711 782 602 00
stuttgart@avnet.eu

Leipzig

Phone: +49 34204 7056 00
Fax: +49 34204 7056 11
leipzig@avnet.eu

Nürnberg

Phone: +49 911 24425 80
Fax: +49 911 24425 85
nuernberg@avnet.eu

Poing

Phone: +49 8121 777 02
Fax: +49 8121 777 531
muenchen@avnet.eu

Wiesbaden

Phone: +49 612 258 710
Fax: +49 612 258 713 33
wiesbaden@avnet.eu

HUNGARY

Budapest
Phone: +36 1 43 67215
Fax: +36 1 43 67213
budapest@avnet.eu

ITALY

Cusano Milanino
Phone: +39 02 660 921
Fax: +39 02 660 923 33
milano@avnet.eu

Firenze

Phone: +39 055 428 2301
Fax: +39 055 431 035
firenze@avnet.eu

Modena

Phone: +39 059 348 933
Fax: +39 059 344 993
modena@avnet.eu

Padova

Phone: +39 049 807 368 9
Fax: +39 049 773 464
padova@avnet.eu

Rivoli

Phone: +39 011 204 437
Fax: +39 011 242 869 9
torino@avnet.eu

Roma Tecnocittà

Phone: +39 06 412 319 10
Fax: +39 06 413 116 1
roma@avnet.eu

NETHERLANDS

Breda
Phone: +31 765 722 700
Fax: +31 765 722 707
breda@avnet.eu

NORWAY

Asker
Phone: +47 667 736 00
Fax: +47 667 736 77
asker@avnet.eu

POLAND

Gdansk
Phone: +48 58 307 81 51
Fax: +48 58 307 81 50
gdansk@avnet.eu

Katowice

Phone: +48 32 259 50 10
Fax: +48 32 259 50 11
katowice@avnet.eu

Warszawa

Phone: +48 222 565 760
Fax: +48 222 565 766
warszawa@avnet.eu

PORTUGAL

Vila Nova de Gaia
Phone: +35 1 223 779 502
Fax: +35 1 223 779 503
porto@avnet.eu

ROMANIA (BULGARIA)

Bucharest
Phone: +40 21 528 16 32
Fax: +40 21 529 68 30
bucuresti@avnet.eu

RUSSIA (BELARUS, UKRAINE)

Moscow
Phone: +7 495 737 36 70
Fax: +7 495 737 36 71
moscow@avnet.eu

Saint Petersburg

Phone: +7 812 245 1571
stpetersburg@avnet.eu

SLOVAKIA

Bratislava
Phone: +421 232 242 211
Fax: +421 232 242 210
bratislava@avnet.eu

SLOVENIA

(BOSNIA AND HERZEGOVINA,
CROATIA, MACEDONIA, MONTENEGRO,
SERBIA)

Ljubljana
Phone: +386 156 097 50
Fax: +386 156 098 78
ljubljana@avnet.eu

SPAIN

Barcelona
Phone: +34 933 278 530
Fax: +34 934 250 544
barcelona@avnet.eu

Galdàcano. Vizcaya

Phone: +34 944 572 777
Fax: +34 944 568 855
bilbao@avnet.eu

Las Matas

Phone: +34 913 727 100
Fax: +34 916 369 788
madrid@avnet.eu

SWEDEN

Sundbyberg
Phone: +46 8 587 461 00
Fax: +46 8 587 461 01
stockholm@avnet.eu

SWITZERLAND

Rothrist
Phone: +41 62 919 555 5
Fax: +41 62 919 550 0
rothrist@avnet.eu

TURKEY (GREECE, EGYPT)

Kadikoy Istanbul
Phone: +90 216 528 834 0
Fax: +90 216 528 834 4
istanbul@avnet.eu

UNITED KINGDOM (IRELAND)

Berkshire
Phone: +44 1628 512 900
Fax: +44 1628 512 999
maidenhead@avnet.eu

Bolton

Phone: +44 1204 547 170
Fax: +44 1204 547 171
bolton@avnet.eu

Bucks, Aylesbury

Phone: +44 1296 678 920
Fax: +44 1296 678 939
aylesbury@avnet.eu

Stevenage, Herts, Meadway

Phone: +44 1438 788 310
Fax: +44 1438 788 250
stevenage@avnet.eu

ISRAEL

Tel-Mond
Phone: +972 (0)9 7780280
Fax: +972 (0)3 760 1115
avnet.israel@avnet.com

SOUTH AFRICA

Cape Town
Phone: +27 (0)21 689 4141
Fax: +27 (0)21 686 4709
sales@avnet.co.za

Durban

Phone: +27 (0)31 266 8104
Fax: +27 (0)31 266 1891
sales@avnet.co.za

Johannesburg

Phone: +27 (0)11 319 8600
Fax: +27 (0)11 319 8650
sales@avnet.co.za



All trademarks and logos are the property of their respective owners. This document provides a brief overview only, no binding offers are intended. No guarantee as to the accuracy or completeness of any information. All information is subject to change, modifications and amendments without notice.